

**PRODUCT MODEL NUMBERS**

WGD6200S  
WGD6400S

**Gas supply:** This dryer is equipped for use with natural gas. It is designed-certified by CSA International for L.P. (propane or butane) gases with appropriate conversion. When rigid pipe is used it should be 1/2" IPS. When acceptable to the gas supplier and local codes, 3/8" approved tubing may be used for lengths under 20 feet. For lengths over 20 feet, larger tubing should be used. Pipe-joint compounds resistant to the action of L.P. gas must be used. If local codes permit, it is recommended that new flexible metal tubing, design-certified by CSA, be used for connecting the appliance to the rigid gas supply line. (The gas pipe which extends through the lower rear of the appliance has 3/8" male pipe thread.) An individual manual shutoff valve must be installed within 6 feet of the dryer in accordance with the National Fuel Gas Code ANSI Z223.1.

**Electrical:** A four-wire or three-wire, single phase, 120-volt, 60 Hz, AC-only, electrical supply is required on a separate 15 or 20 amp circuit, fused on both sides of the line. A time-delay fuse or circuit breaker is recommended.

**Exhaust venting:** Exhaust your dryer to the outside. Four-inch diameter vent is required. Rigid or flexible metal exhaust vent must be used. Do Not use plastic or metal foil vent. Exhaust outlet hood must be at least 12" from the ground or any object that may be in the path of the exhaust.

**OVERALL DIMENSIONS**

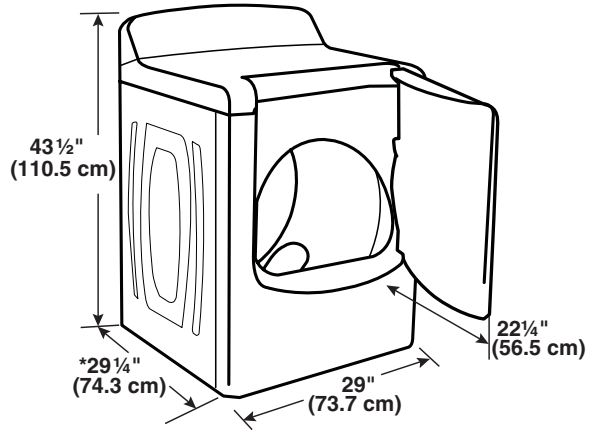

\*Most installations require a minimum 5" (12.7 cm) clearance behind the dryer for the exhaust vent with elbow.

**RECESSED AREA AND CLOSET INSTALLATION**

For closet installation with a door, minimum ventilation openings in the top and bottom of the door are required. Louvered doors with equivalent air openings are acceptable.

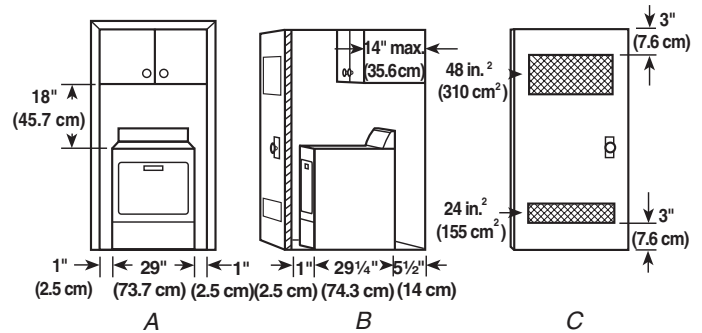

A. Recessed area  
B. Side view - closet or confined area  
C. Closet door with vents

**EXHAUST VENTING**

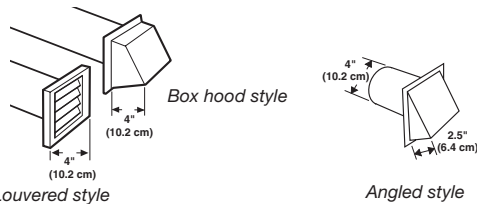

**Vent Length Chart**

Number of 90° turns or elbows	Type of vent	Box or Louvered hoods	Angled hoods
0	Rigid metal	64 ft (20 m)	58 ft (17.7 m)
	Flexible metal	36 ft (11 m)	28 ft (8.5 m)
1	Rigid metal	54 ft (16.5 m)	48 ft (14.6 m)
	Flexible metal	31 ft (9.4 m)	23 ft (7 m)
2	Rigid metal	44 ft (13.4 m)	38 ft (11.6 m)
	Flexible metal	27 ft (8.2 m)	19 ft (5.8 m)
3	Rigid metal	35 ft (10.7 m)	29 ft (8.8 m)
	Flexible metal	25 ft (7.6 m)	17 ft (5.2 m)
4	Rigid metal	27 ft (8.2 m)	21 ft (6.4 m)
	Flexible metal	23 ft (7 m)	15 ft (4.6 m)

1. Select the route that will provide the straightest and most direct path outdoors. Plan the installation to use the fewest number of elbows and turns. When using elbows or making turns, allow as much room as possible. Bend vent gradually to avoid kinking. Avoid 90° turns.

2. Determine vent length.

The maximum length of the exhaust system depends upon:

- The type of vent (rigid metal or flexible metal).
- The number of elbows used.
- Type of hood.

See the exhaust vent length chart that matches your hood type for the maximum vent lengths you can use.

3. Determine the number of elbows you will need.

**IMPORTANT:** Do not use vent runs longer than specified in the Vent Length Chart.

In the column listing the type of metal vent you are using (rigid metal or flexible metal), find the maximum length of metal vent on the same line as the number of elbows.