

# FOR SERVICE TECHNICIAN'S USE ONLY

## Wiring Diagram

Do Not Remove Or Destroy

### Quick Connect Plugs

For oven controls

P1 (Red)

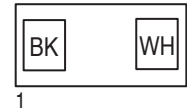

P2 (Blue)



P3 (Red)

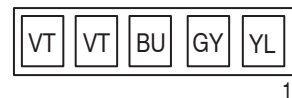

P4 (Red)

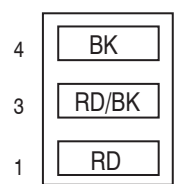

P5 (Blue)

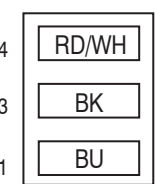

P10 (Yellow)

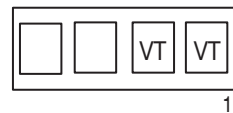

### Oven Control Wiring Diagram

NOTE: Schematic shows oven door open and elements off.

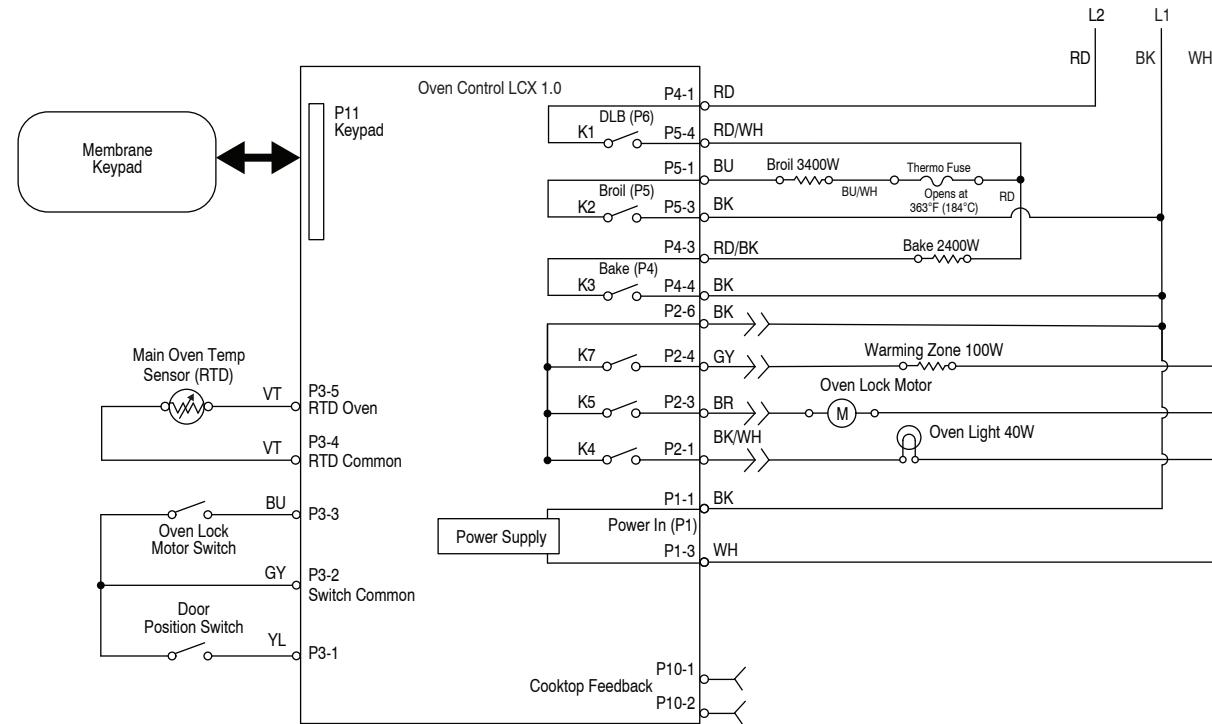

### Cooktop Wiring Diagram

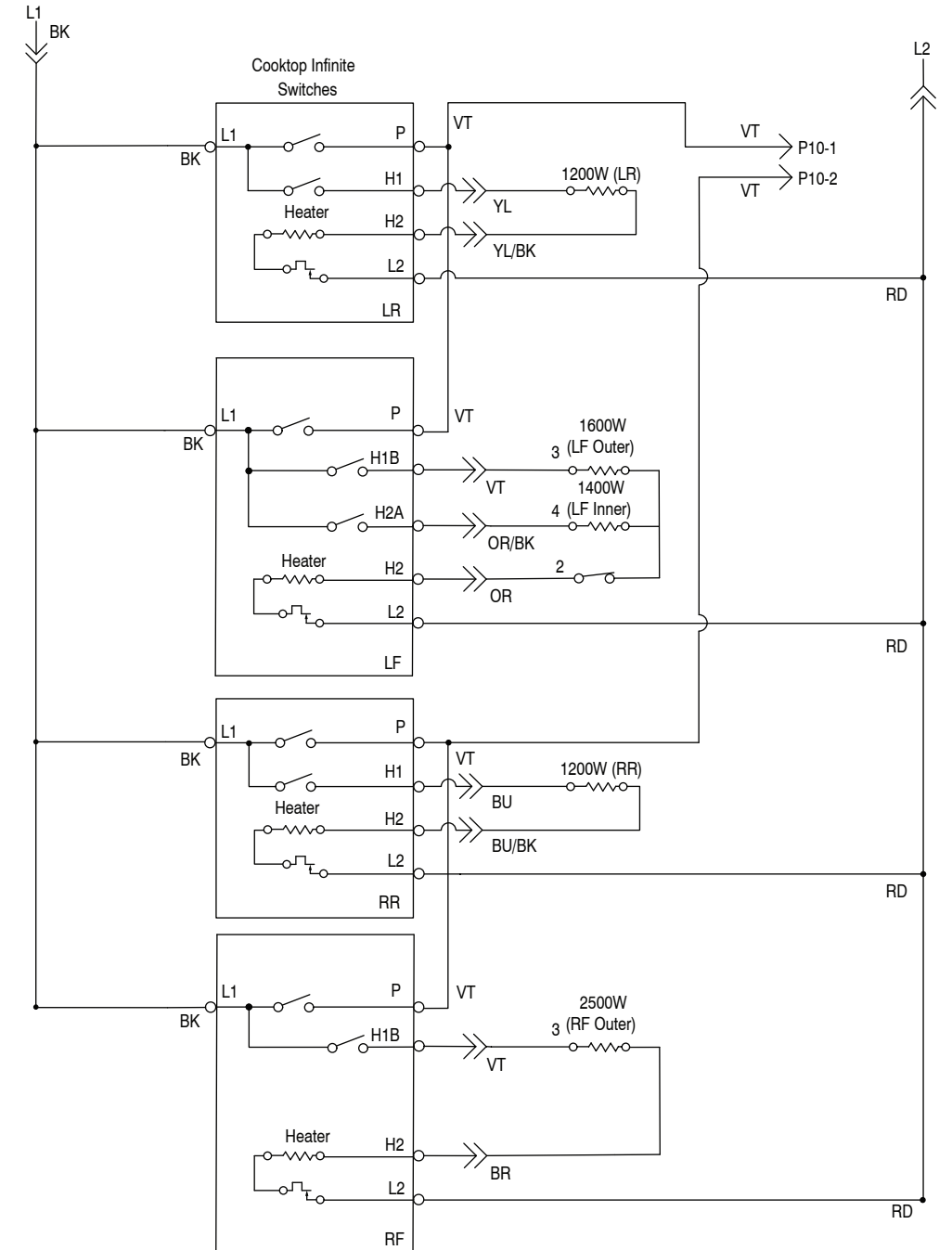

### LEGEND

Connection	No Connection	On Some Models	In-Line Connection	Connector P2, Position 1	Circuitry Enclosed Within	Terminals	Single Switch	Thermal Switch (opens on heat rise)	Thermal Switch (closes on heat rise)	Resistor or Element	Motor	Incandescent Light	Non-resettable Fuse	Thermistor	Indicator Light	Triac	Thermo Fuse

## Fiches à connexion rapide

Pour les commandes du four

P1 (Rouge)

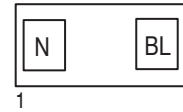

1

P2 (Bleu)



1

P3 (Rouge)

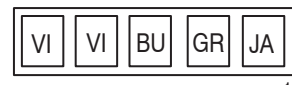

1

P4 (Rouge)

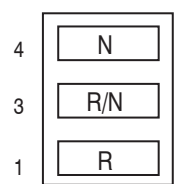

4

3

1

P5 (Bleu)

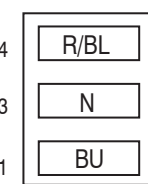

4

3

1

P10 (Jaune)

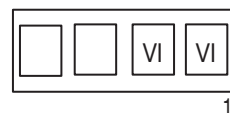

1

## Schéma de câblage du module de commande du four

REMARQUE : Le schéma montre la porte du four ouverte et les éléments éteints.

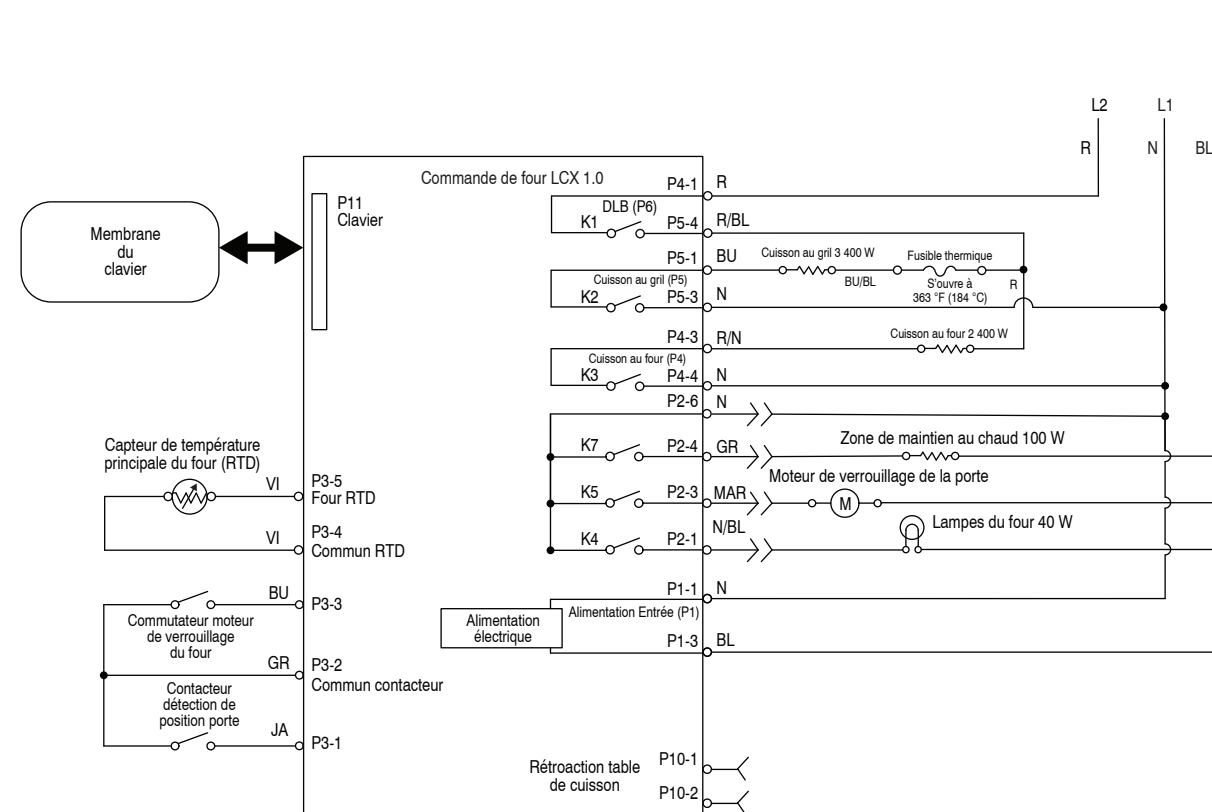

## Schéma de câblage de la table de cuisson

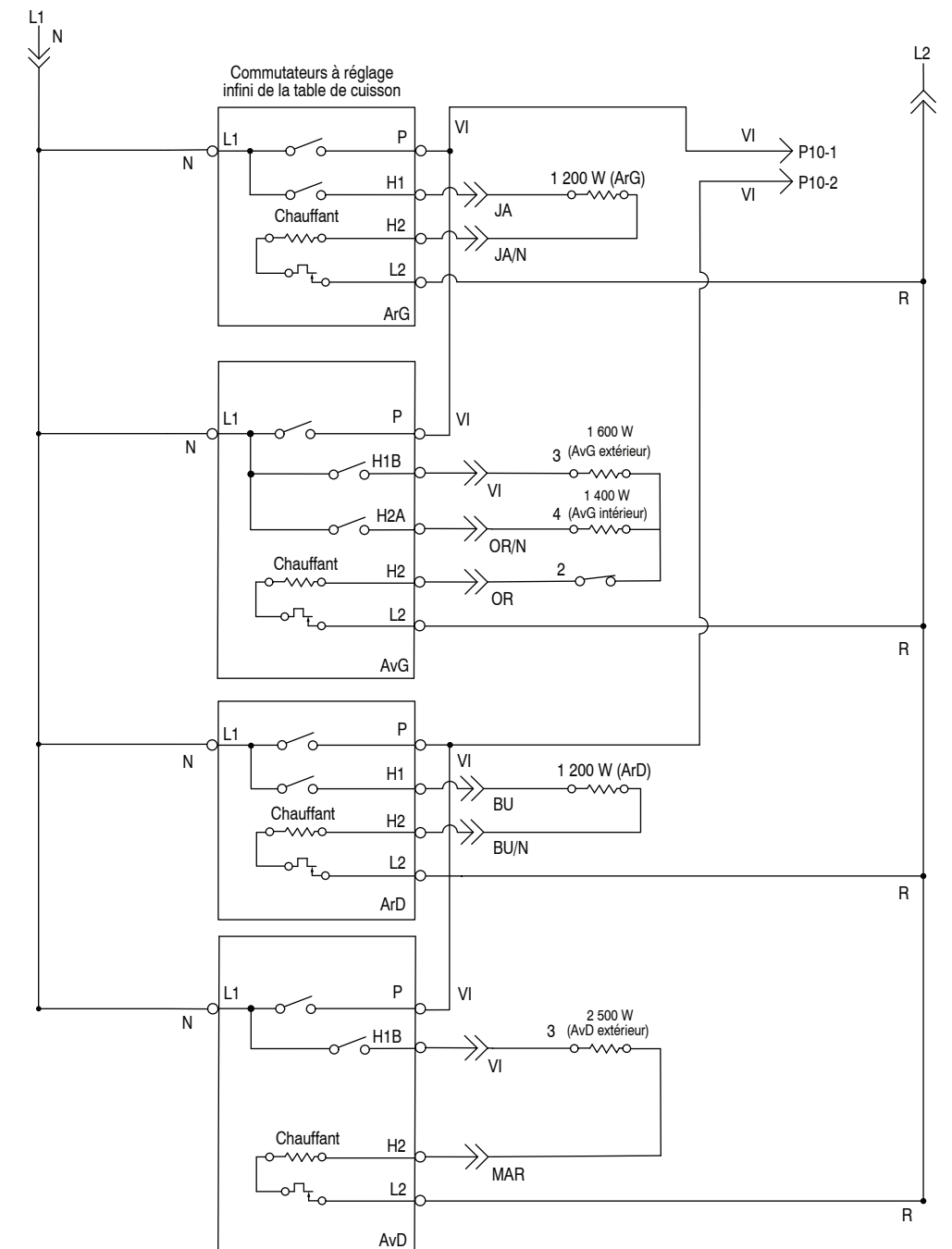

## LÉGENDE

Connexion	Pas de connexion	Sur certains modèles	Connexion en série	Connecteur P2, position 1	Circuit à l'intérieur	Broches du composant	Contacteur simple	Commutateur thermique (s'ouvre lorsque la chaleur augmente)	Commutateur thermique (se ferme lorsque la chaleur augmente)	Résistance ou élément	Moteur	Lampe à incandescence	Fusible non réarmable	Thermistance	Témoin lumineux	Triac	Fusible thermique

# PARA SER USADO ÚNICAMENTE POR TÉCNICOS DE SERVICIO

## Diagrama de cableado

No Quitar Ni Destruir

### Enchufes de conexión rápida

Para controles del horno

P1 (Rojo)

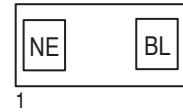

P2 (Azul)

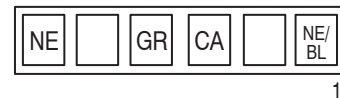

P3 (Rojo)

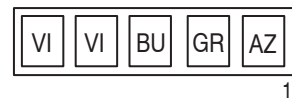

P4 (Rojo)

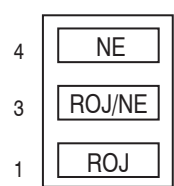

P5 (Azul)

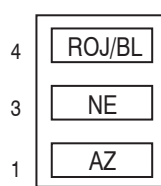

P10 (Amarillo)

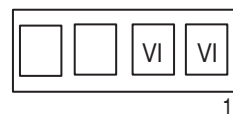

### Diagrama de cableado de control del horno

NOTA: El diagrama esquemático muestra la puerta del horno abierta y los elementos apagados.

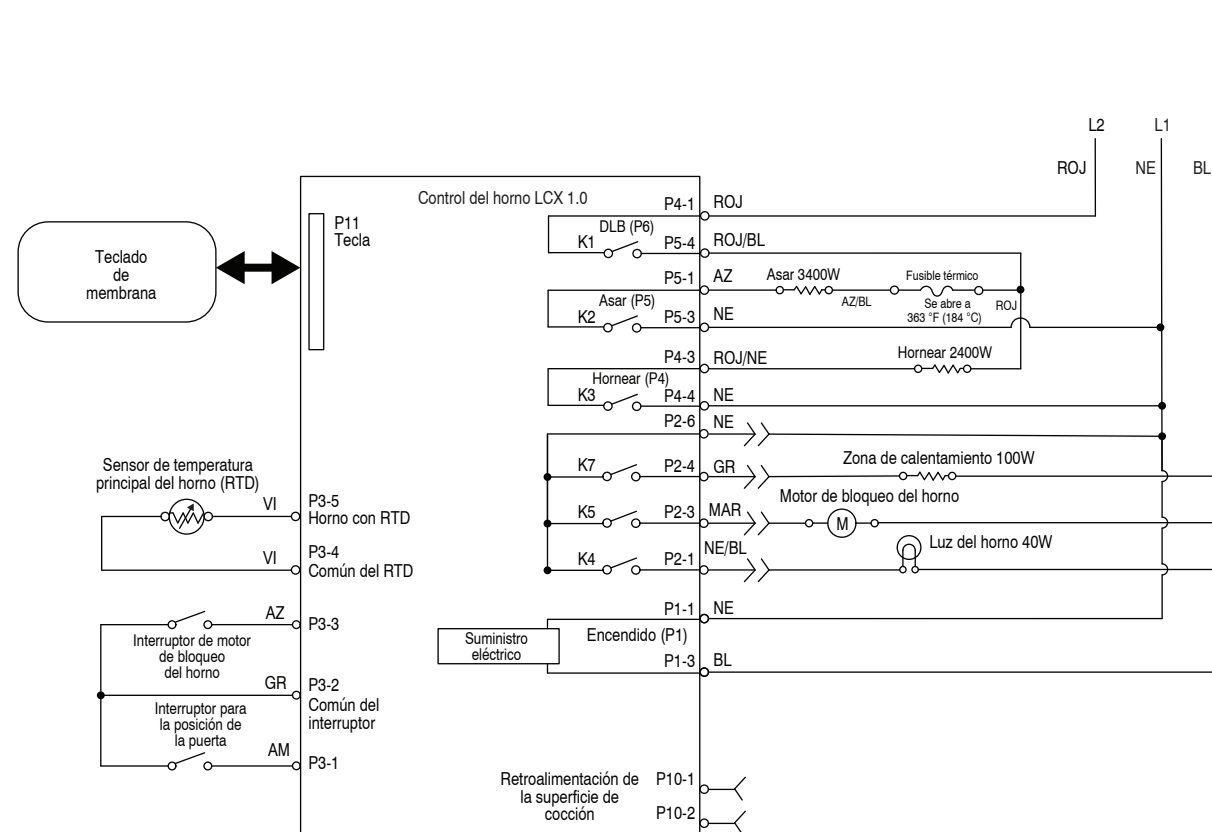

### Diagrama de cableado de superficie de cocción

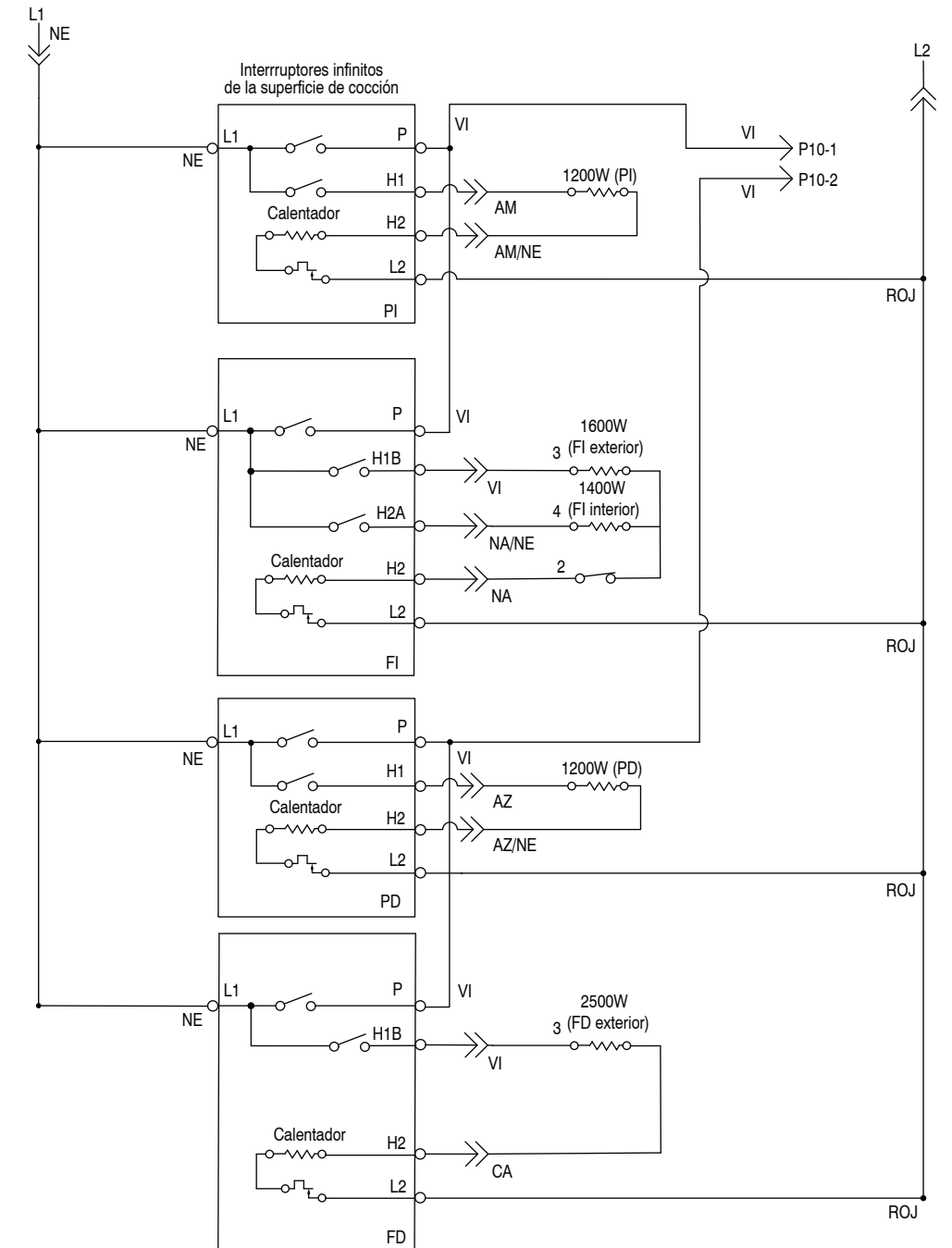

### LEYENDA

Conexión	No hay conexión	En algunos modelos	Conexión en línea	Conector P2, Posición 1	Circuito cerrado	Terminales	Interruptor simple	Interruptor térmico (se abre con un alza de calor)	Interruptor térmico (se cierra con un alza de calor)	Resistor o Elemento	Motor	Luz incandescente	Fusible no reajustable	Termistor	Luz indicadora	Triac	Fusible térmico