



## 29" Electric Dryer

### PRODUCT MODEL NUMBERS

WED4750X, WED4800X, WED4900X,  
WED4850X, WED4890X

**Electrical:** This dryer requires a 3 or 4 wire, single phase, 120/240 volt, 60 Hz., AC only electrical supply (or 3 or 4 wire, 120/208 volt electrical supply, if specified on the serial/rating plate) on a separate 30-amp circuit, fused on both sides of the line. A time-delay fuse or circuit breaker is recommended. Connect to an individual branch circuit. Do not have a fuse in the neutral or grounding circuit.

**Water (Steam models only):** The dryer must be connected to the cold water faucet using new inlet hoses. Do not use old hoses. Do not overtighten. Damage to the coupling can result.

**Exhaust venting:** Exhaust your dryer to the outside. 4" (102 mm) diameter vent is required. Rigid or flexible metal exhaust vent must be used. Do not use plastic or metal foil vet. Exhaust hood must be at least 12" (305 mm) from the ground or any object that may be in the path of the exhaust.

Hood styles: A & B are recommended.

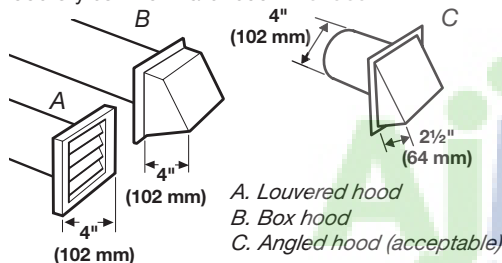

The Vent system chart provides venting requirements that will help achieve best drying performance.

**NOTE:** Side and bottom exhaust installation have a 90° turn inside the dryer. To determine maximum exhaust length, add a 90° turn to the total number of elbows when referencing the chart.

Vent system chart			
Number of 90° elbows	Type of vent	Box/louvered hoods	Angled hoods
0	Rigid metal	64 ft. (20 m)	58 ft. (17.7 m)
1	Rigid metal	54 ft. (16.5 m)	48 ft. (14.6 m)
2	Rigid metal	44 ft. (13.4 m)	38 ft. (11.6 m)
3	Rigid metal	35 ft. (10.7 m)	29 ft. (8.8 m)
4	Rigid metal	27 ft. (8.2 m)	21 ft. (6.4 m)

Vent System Chart (Long Vent Models Only)		
Number of 90° turns or elbows	Type of vent	Box/louvered, or Angled hoods
0	Rigid metal	120 ft. (36.6 m)
1	Rigid metal	110 ft. (33.5 m)
2	Rigid metal	100 ft. (30.5 m)
3	Rigid metal	90 ft. (27.4 m)
4	Rigid metal	80 ft. (24.4 m)
5	Rigid metal	70 ft. (21.3 m)

### OVERALL DIMENSIONS

#### Dryer dimensions

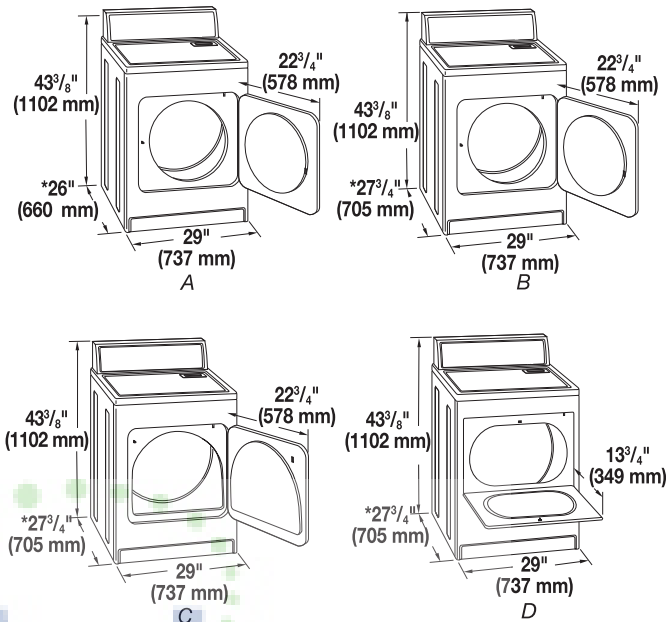

A. Large opening side-swing door  
B. Large opening side-swing door  
C. Wide opening side-swing door  
D. Wide opening hamper door

#### Minimum Required Spacing

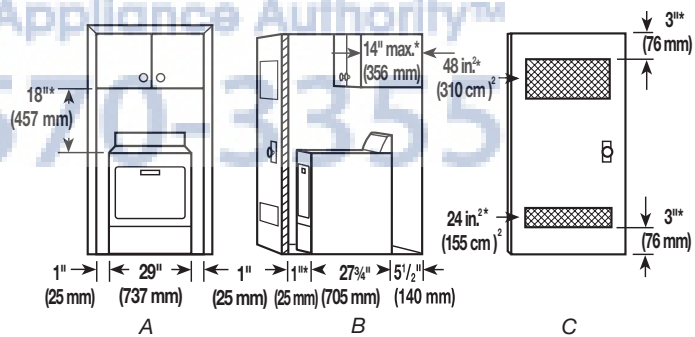

A. Recessed area  
B. Side view - closet or confined area  
C. Closet door with vents

For closet installation, with a door, the minimum ventilation openings in the top and bottom of the door are required. Louvered doors with equivalent air ventilation openings are acceptable.

Most installations require a minimum 5 1/2" (140 mm) clearance behind the dryer for the exhaust vent with elbow. See "Venting Requirements."

Do not use vent runs longer than specified in vent length chart.

Determine the number of elbows you will need.

Select the route that will provide the straightest and most direct path outdoors.

Plan the installation to use the fewest number of elbows and turns.

Use the fewest 90° turns possible.