



# 5 SERIES 30" AND 36"W. DUAL FUEL RANGES

Viking 5 Series – VDR

## COMMERCIAL-TYPE COOKING POWER

- **EXCLUSIVE** – VSH (VariSimmer-to-high) Pro sealed burner system
  - TruPowerPlus 18,500 BTU front right burner (select models)
  - All other burners are 15,000 BTUs
- **EXCLUSIVE** – *VariSimmer™ Setting* for all burners
- **EXCLUSIVE** – all burners equipped with *SureSpark™ Ignition System* for consistent and reliable ignition every time
  - Automatic re-ignition; surface burners light at any position on the knob and re-light if extinguished, even on lowest setting
- Heavy-duty BlackChrome™ knobs and square bezels shipped standard
- One of the largest oven cavities in the industry
- **EXCLUSIVE** – patented *Vari-Speed Dual Flow™ Convection System* has the largest convection fan in the industry; the 8 1/2" fan works bi-directionally for maximum airflow and excellent cooking results
- Concealed 10-pass dual bake element provides precise temperature control
- Large 10-pass broiler with heat reflector
- *Rapid Ready™ Preheat* provides one of the fastest preheat times, so your oven is ready to begin cooking when you are
- Oven has six porcelain-coated rack positions and comes standard with three racks
- **EXCLUSIVE** – Gentle Close™ Door allows door to close slowly
- Three strategically located oven lights provide maximum visibility
- High-performance cooking modes include bake, convection bake, *TruConvec™ Convection Cooking*, convection roast, broil, convection broil, convection dehydrate, and convection defrost



- Burner caps are easily removable for quick cleaning
- Heavy-duty, porcelainized, cast-iron removable surface grates provide continuous front-to-rear, left-to-right surface for easy movement of large pots
- Self-cleaning porcelain ovens
- Concealed bake element(s) make for easy cleanup of oven cavity

## EASY OPERATION AND CLEANUP

- **EXCLUSIVE** – one-piece tooled and porcelainized cooking surface for easy cleanup



## MODEL NUMBERS

- VDR5304B – 30"W. Dual Fuel Range; four burners
- VDR5366B – 36"W. Dual Fuel Range; six burners
- VDR5364G – 36"W. Dual Fuel Range; four burners with griddle

## ACCESSORIES

- BG8530SS – 8"H. backguard for 30" range
- BG8536SS – 8"H. backguard for 36" range
- HS24530SS – high shelf for 30" range
- HS24536SS – high shelf for 36" range
- P24CSTSS – countertop side trim (2 pieces)
- P30CRTSS – countertop rear trim for 30" range
- P36CRTSS – countertop rear trim for 36" range
- P30CBF4SS – curb base and custom curb base front for 30" range
- P36CBF4SS – curb base and custom curb base front for 36" range
- LPKPDR – LP/Propane Conversion Kit

## COLOR FINISHES

- Stainless Steel (SS) 
- Volume 1 Color Finishes include Antique Bronze (AN), Blush (BH), Cast Black (CS), Damascus Gray (DG), Eucalyptus (EU), Ivy (IV), Martini (MA), November Sky (NS), Slate Blue (SB), Spiced Cider (SC), Splash (SP) 
- Volume 2 Color Finishes include Daffodil (DA), Golden Hour (GH), Nantucket (NA), Onyx (ON), Pure White (PW), Squall (SQ), Valentine (VA) 

## BRUSHED BRASS ACCENT

- Available on Stainless Steel Finish (standard order) and Volume 1/Volume 2 Color Finishes (special order)
- Brass Accent includes handle endcaps, knob bezels, and logo
- Models ordered in Brass Accent will ship with stainless steel knobs and round knob bezels

## WARRANTY

- 2-year full – complete product
- 90-day full – cosmetic parts such as glass, painted items and decorative items
- 5-year limited – gas burners and electric oven elements



# 5 SERIES 30" AND 36"W. DUAL FUEL RANGES

Viking 5 Series – VDR

DUAL FUEL 30" AND 36" W. RANGES		
DESCRIPTION	VDR530	VDR536
Overall Width	29-7/8" (75.9 cm)	35-7/8" (91.1 cm)
Overall Height from Bottom	Base Height To top of side trim – minimum 35-7/8" (91.1 cm) to maximum 37" (94 cm); legs adjust 1-1/8" (2.9 cm) Additions to Base Height To top of island trim – add 1" (2.5 cm); to top of backguard – add 8" (20.3 cm) To top of high shelf – add 23-1/2" (59.7 cm)	
Overall Depth from Rear	To end of side panel – 24-5/16" (61.8 cm); to front of door – 25-3/4" (65.4 cm) To end of door handle – 28-11/16" (72.9 cm)	
Gas Requirements	Shipped natural or LP/Propane gas; field convertible from natural to LP with conversion kit (purchased separately); accepts standard residential 1/2" (1.3 cm) ID gas service line	
Electrical Requirements	240-208VAC, 60 Hz electrical connection box on product, connect with locally supplied 3-wire, flexible cord or "pigtail"	
Maximum Amp Usage	240V – 26.8 amps; 208V – 22.8 amps	240V – 30.5 amps; 208V – 26.4 amps
Surface Burner Rating	Power Burner 18,500 BTU (5.4 kW); 16,600 BTU (4.9 kW); Other Burners 15,000 BTU (4.4 kW); 12,500 BTU (3.7 kW)	
Griddle Burner Rating	–	15,000 BTU NAT./12,500 BTU LP (4.4 kW NAT./3.7 kW LP)
Oven Interior Dimensions	Convection Bake/Broil Overall Width – 25-5/16" (64.6 cm) Height – 16-1/2" (41.9 cm) Depth – 19-1/2" (49.5 cm); Overall Size – 4.7 cu. ft. AHAM Standard* – 4.1 cu. ft. 3 racks, 6 rack positions	Convection Bake/Broil Overall Width – 30" (78.6 cm); Height – 16-1/2" (41.9 cm) Depth – 19-1/2" (49.5 cm); Overall Size – 5.6 cu. ft. AHAM Standard* – 4.9 cu. ft. 3 racks, 6 rack positions
Approximate Shipping Weight	410 lb. (186.4 kg)	500 lb. (225 kg)

Please do not prepare installation from brochure data only. See installation instructions for important clearance/installation information.  
 \*\*The AHAM Standard for measuring oven capacity subtracts the door plug and convection baffle dimension from the total oven volume.

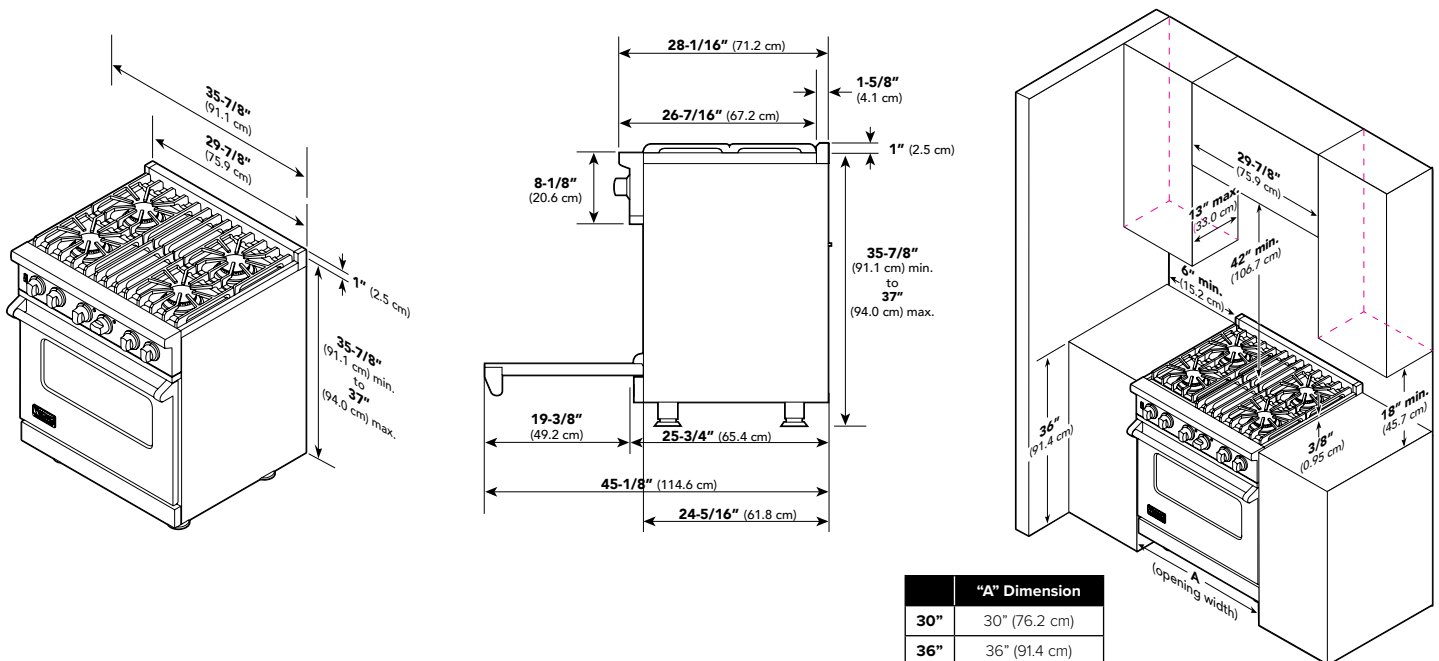

VIKING RANGE, LLC 111 FRONT STREET GREENWOOD, MISSISSIPPI 38930 USA

For detailed product information, model numbers, or to request a quote call 1-888-845-4641 or visit [vikingrange.com](http://vikingrange.com)  
 © 2024 Viking Range, LLC All rights reserved. Specifications subject to change without notice.

