

Operating and Assembly Instructions

# **VR 421-611**

Electric Grill

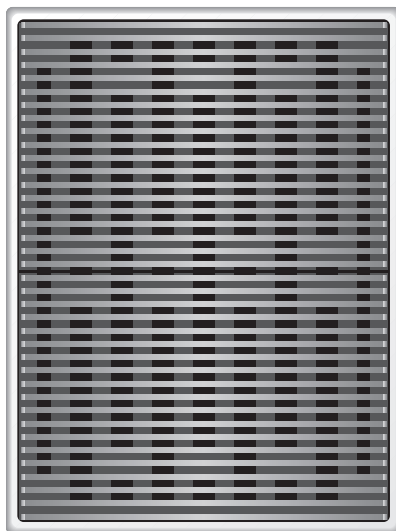

**GAGGENAU**



<b>Important Safeguards</b>	<b>Page 3</b>
<b>1. Important Notes</b>	<b>Page 4-5</b>
For your safety	Page 4
Operating for the first time	Page 5
About use	Page 5
<b>2. Features</b>	<b>Page 6</b>
Features	Page 6
Included accessories	Page 6
Special accessories	Page 6
<b>3. Operation</b>	<b>Page 7-8</b>
Switching on	Page 7
Switching off	Page 8
Residual heat display	Page 8
Holiday safeguard	Page 8
<b>4. Operation with griddle plate</b>	<b>Page 9</b>
<b>5. Settings Table</b>	<b>Page 10</b>
<b>6. Tips for grilling</b>	<b>Page 11-12</b>
<b>7. Cleaning and care</b>	<b>Page 13</b>
<b>8. Maintenance</b>	<b>Page 14</b>
<b>9. Installation</b>	<b>Page 15-20</b>
Technical data	Page 15
Important notes on installation	Page 15
Electrical connection	Page 15
Preparing the cabinet	Page 16-17
Installing the control panel	Page 18
Installing the grill	Page 19
Fitting the appliance cover	Page 20

**Congratulations on purchasing your new “Vario” appliance.**

Before switching your appliance on for the first time, we would like you to familiarize yourself with your new appliance. In this manual you will find important instructions on safety and operation. They will serve to ensure your personal safety and the long lasting use of your appliance.

You will find instructions on Page 5 that you must read before operating the appliance for the first time.

The chapters “Features” and “Operation” tell you what your appliance can do and how you operate it.

The chapter “Cleaning and care” gives tips on how to keep your appliance in the best proper working condition.

**And now we wish you lots of fun with your grill!**



# Important Safeguards

---

## 1. **Read All Instructions.**

2. To eliminate the risk of burns or fire by reaching over the heated surface units, cabinet storage space located above the surface units should be avoided.

## 3. **Important instructions**

- a) Ensure that this appliance is properly connected and grounded by a qualified electrician.
- b) Never use this appliance for warming or heating the room.
- c) Do Not Leave Children Alone – Children should not be left alone or unattended in area where appliances are in use. They should never be allowed to sit or stand on any part of the appliance.
- d) Wear Proper Apparel – Loose fitting or hanging garments should never be worn while using the appliance.
- e) User Servicing – Do not repair or replace any part of the appliance unless specifically recommended in the manual. All other servicing should be referred to a qualified technician.
- f) Storage in or on Appliance – Flammable materials should not be stored in an oven or near surface units.
- g) Do Not Use Water on Grease Fires – Smother fire or flame or use dry chemical or foam-type extinguisher.
- h) Use Only Dry Potholders – Moist or damp potholders on hot surface may result in burns from steam. Do not let potholders touch hot heating elements. Do not use a towel or other bulky cloth.

4. **DO NOT TOUCH HEATING ELEMENTS OR AREAS NEAR UNITS.** Heating elements may be hot even though they are dark in color. Areas near heating elements may become hot enough to cause burns. During and after use, do not touch or let clothing or other flammable materials contact heating elements or areas near units until they have had sufficient time to cool.
5. Never leave electric grill unattended when cooking, especially if using high settings. When grilling meats with considerable fat content, care must be observed as flare-up fires are likely. These flare-up fires are normal and do no harm to the unit, although it is necessary to pay attention to the open flame.
6. **CAUTION:** Do not store items of interest to children in cabinets above a range. Children climbing on the appliance to reach items could be seriously injured.
7. **Note** – To avoid jeopardising the electrical safety of the appliance, it is forbidden to use high-pressure or steam jet cleaning devices.

## 8. **Save These Instructions.**

# 1. Important Notes

---

## **For your safety**

Do not operate the appliance if it is damaged.

The appliance must only be connected by an authorised specialist, paying attention to the relevant regulations of the power supply companies and the regional construction regulations. Observe the assembly instructions!

When connecting electrical appliances in the proximity of the grill, make sure that connecting cables do not come into contact with hot cooking surfaces.

Only ever operate the appliance under supervision. Observe caution with oils and fats. Overheated oils and fats can easily cause fires.

**Caution:** the appliance heats up during operation. Keep children away.

To avoid jeopardising the electrical safety of the appliance, do not use high-pressure or steam jet cleaning devices.

Do not store any substances that are sensitive to high temperatures, or which pose a fire hazard (e.g. cleaning agents or spray cans), in drawers or cupboards under the appliance.

Isolate the appliance from the mains during every maintenance operation. To do this, remove the mains plug or switch off the corresponding fuse.

Repairs must be carried out by authorised specialists, thus ensuring electrical safety.

As the user, you are responsible for maintenance and proper use in the household. No warranty claims can be considered for any damage resulting from failure to follow these instructions.

### **Note:**

the appliance cover must not be closed until the appliance has cooled down completely. Do not operate the appliance with the cover closed! Heat development may damage the appliance and the cover. Do not use the appliance cover as a surface for placing objects or for keeping things warm.

Subject to technical change without notice.

---

## **Operating for the first time**

Remove the packaging from the appliance and dispose of it according to local regulations. Be careful to remove all accessories from the packaging. Keep packaging elements and plastic bags away from children.

Check the appliance for transport damage before installing it.

The appliance must be installed and connected by an authorised specialist before operation. Before operating the appliance for the first time, make sure that the mains connection is in proper working order.

The serial number of the appliance can be found on the quality control slip which is included with these instructions. This quality control slip should be kept, for warranty reasons, together with your operating and assembly instructions.

Read through these instructions carefully before operating your appliance for the first time.

Before using the appliance for the first time, take the lava stones out of the plastic bag and pour them into the lava stone container.

Thoroughly clean the appliance and accessories before using them for the first time. Then heat up the appliance at level 12 for a few minutes. This will eliminate any 'newness' smells and soiling.

## **About use**

The appliance is intended solely for household use and must not be put to any other uses.

Use the appliance to prepare meals only. Do not use the appliance to heat up the room in which it is installed.

Do not use the appliance to store items.

Switch off the grill after use. Allow the grill to cool down and then clean. We recommend you clean the grill after every use. A greasy grill is a fire risk.

Built-in overheating protection prevents overheating of the appliance and of surrounding kitchen furniture.

In the event of malfunction, first check your household fuses. If the power supply is in proper working order, and the appliance is still not functioning, please inform your specialist dealer or your nearest Gaggenau customer service.

## 2. Features

### Features

- 1 Appliance cover
- 2 Cast grid iron (two parts, detachable)
- 3 Work surface
- 4 Grilling elements
- 5 Lava stone container to accommodate the lava stones
- 6 Grease tray (dishwasher-proof)
- 7 Control knob for front grilling element
- 8 Control knob for rear grilling element

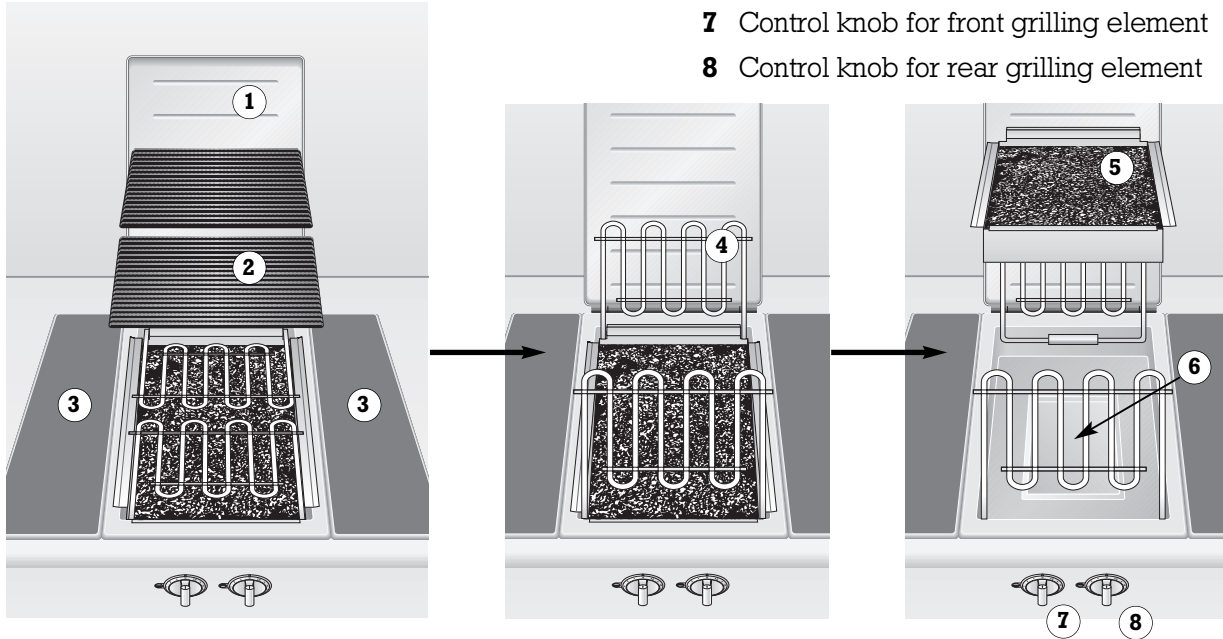

### Included accessories

- Lava stones LV 030-000
- Grilling tongs
- Cleaning brush
- Griddle plate AM 400-000

### Special accessories

You can order the following special accessories:  
**VV 400-000** Connecting trim  
**VZ 400-700** Connecting trim with timer

## 3. Operation

### Switching on

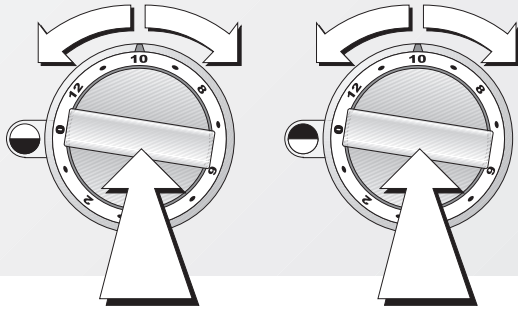

### Note:

before switching on, make sure that there are lava stones in the appliance and both grid irons are correctly fitted.

Place the grid irons on the grill, so that they cover the heating elements. This guarantees a good transfer of heat onto the grid irons. Fat will drip over the lava stones into the grease tray and will not drip onto the heating elements.

The lava stones guarantee an even, intensive transfer of heat. Only operate the grill with lava stones. Take the lava stones out of the plastic bag and pour them into the lava stone container. The contents of one bag is sufficient.

### Caution!

Grilling produces very high temperatures. Keep children away!

Never switch on the appliance with the cover closed.

### Switching on

Press down the control knobs and turn them left or right to the required position (1-12). For grilling, choose a level between 7 and 12. The grill will heat to the optimum temperature for the chosen level. The luminous discs behind the control knobs flash, as long as the appliance heats up. When the correct temperature for the chosen level has been reached, the luminous discs light constantly. After the appliance has heated up, you can put on the food to be grilled.

You can also turn on only one of the two heating elements or you can choose different temperature levels for each element. This enables you to grill different foods at the same time, or you can use one area to grill and the other to keep warm.

### Please note:

- Moist food should be dried, before placing on grill.
- The more moist the food is, the more smoke may be produced!
- During grilling, dripping fat may flare up briefly.

### Power levels of the grill:

- level 1 - 6: keeping warm, leaving to rest (e.g. steaks)
- level 7 - 8: grilling – thicker food with longer grilling times (e.g. chicken legs), fragile food (e.g. fish)
- level 9 - 10: grilling – normal food
- level 11 - 12: grilling – thinner food with shorter grilling times (e.g. pork steak), beef steaks (leave to rest after grilling on a lower level)

## Switching off

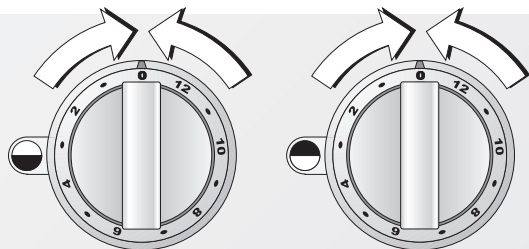

## Switching off

Fully turn both control knobs to the OFF position.

## Residual heat display

After switching both control knobs to the OFF position, the luminous discs behind the control knobs will flash, as long as the grill has not cooled down sufficiently to be touched safely.

**Caution!** The appliance must not be touched until the residual heat display has gone off! **Risk of burns!**

Do not close the cover until the appliance has cooled down completely!

## Holiday safeguard (Automatic switch-off)

The grill is set to automatically switch off 4 hours after the last operation. The luminous discs behind the control knobs flash. Turn both control knobs to 0. Now the grill can be switched on again.

Luminous disc behind control knob	Signification	Cause / Remedy	
○	lights OFF	grill OFF	
●	lights constantly	grill ON	normal use
★	slow flashing	grill ON, heating up	normal use
★	slow flashing	residual heat display	The appliance is too hot to be touched safely.
★	fast flashing	holiday safeguard	The appliance setting has not been changed for over 4 hours. Turn right control knob to 0 and then switch on again if required.
★	fast flashing	power cut	After a power cut, the appliance stays switched off for safety reasons. Turn control knob to 0 and then switch on again if necessary.

## 4. Operation with griddle plate



### **Note:**

make sure before switching on that there are lava stones in the appliance. The lava stones guarantee an even, intensive transfer of heat. Only operate the grill with lava stones.

Remove both grid irons.

Place the griddle plate on the grill, so that the feet of the griddle plate lie on the lava stone container. The griddle plate should be centered on the grill and should not touch the appliance cover.

Press down the control knobs and turn them left or right to the required position (1-12). Choose the same level with both control knobs:

level 1 - 6: keeping warm, simmering

level 7 - 12: setting (egg dishes), baking, roasting, frying

The luminous discs behind the control knobs flash, as long as the appliance heats up. The luminous disc lights constantly, when the chosen temperature level has been reached. After the appliance has heated up, you can put on the food to be grilled.

The griddle plate is particularly suitable for preparing fish, vegetables, sweets (e.g. pancakes), but also meat.

## 5. Settings Table

The specified grilling times serve as guide values only.

Item	Level*	Grilling time*	Remarks
<b>Meats</b>			
Beef steak	11 to 12	4 - 5 min. each side	Turn, when the steak comes off easily from the grid iron. The steak is medium, when juice forms on the top.
Veal chop	9 to 11	2 x 3 min. each side (lozenge pattern)	Notch chops several times on the bone and in the fat layer so they do not curve during grilling.
Kebab (skewers)	9 to 11	10 - 15 min., turn several times	Choose similar sized food pieces with similar grilling times.
Lamb chop	9 to 11	2 x 3 min. each side (lozenge pattern)	Marinate or oil chops. Notch them several times on the bone and in the fat layer so they do not curve during grilling.
Back of pork steak	10 to 12	2 - 3 min. each side	
Pork belly slices	9 to 11	6 - 8 min. each side	Oiled pork belly slices ignite easily.
Grilled sausage	10	8 - 12 min.	Cut into sausages so they do not burst.
Beefburger	11	8 - 10 min.	
<b>Poultry</b>			
Turkey breast	10 to 11	4 - 6 min.	
Poultry skewers	8 to 9	10 - 15 min., turn several times	Skewer poultry alternately with fruits, for example, and marinate it in a sweet-sour marinade.
<b>Fish and seafoods</b>			
Shrimp skewers	8 to 10	8 - 10 min., turn several times	Marinate shrimps with garlic, olive oil and spices, for example.
Filled squid	8 to 10	10 - 12 min., turn several times	Boil squid beforehand.
Tuna fish cutlet	8 to 10	8 - 10 min. each side	Marinate cutlets beforehand.
Trout, whole	8 to 10	15 min.	Coat trout with oil to make sure the skin does not stick to the gridiron. Turn after half the grilling time. The trout will be ready, when the eye goes white.
<b>Side dishes</b>			
Fruits (e.g. bananas, apple slices or pear halves)	9 to 10	1 - 2 min. each side	
Mushrooms (e.g. mushroom slices or oyster mushrooms)	9 to 10	1 - 2 min. each side	If necessary, marinate mushrooms or coat them lightly with oil.

\* Rough values

## 6. Tips for grilling

---

- The grilled result depends on the nature and quality of the meat and on your personal taste.
- If possible, grilled pieces should be equally thick. In this way, they will brown evenly and they will stay nice and juicy.
- Always preheat the grill. The intensive heat radiation will seal the surface of the grilled food and juice cannot leak.
- Place grilled pieces directly on the grid iron. If there is only one piece for grilling, place it on the grid iron, as far as possible in the middle, over the switched-on heating element. The best results are obtained this way. Turn grilled pieces over as soon as they can be removed easily from the grid iron. The pores have now been sealed.
- Always grill steaks unsalted. Otherwise, water and soluble nutrients might leak and be lost.
- Avoid conserved foods such as boiled ham and smoked pork etc. Otherwise, a compound may be produced that is harmful to health.
- To avoid drying out of the surface and to improve the taste, lightly brush grilled food with heat-resistant oil (e.g. peanut oil). Make sure you do not use too much oil. Otherwise, there will be a risk of fire.
- You might notice that the grilling element switches on and off automatically during the grilling time. This is normal.
- Poultry becomes particularly crispy brown if you coat it with butter, salty water or orange juice towards the end of the cooking time.
- Serve grilled food hot.
- Meat is medium if juice leaks out of the surface of a steak (pink inside and crispy brown on the outside).
- Do not pierce the meat while grilling it. It may lose its juice. Turn the meat when small drips can be seen on its surface.
- Do not remove the fatty layer (i.e. on a cutlet) until after grilling. Otherwise, the meat will lose juice and aroma.

### **Would you have known?**

#### **Advantages of grilling**

No or little fat is used when grilling. Therefore, it is a low-fat preparation method.

Grilling is a gentle cooking method in which nutrients, taste and aroma substances are largely retained. Grilled foodstuffs are easy on the stomach because they are prepared without fat and sauces.

During grilling, intensive browning appears on the surface of foodstuffs, but no crust, with the result that grilled foods are easy to digest and are suitable for people on diets.

---

## **Beef**

Tender cuts of beef are particularly suitable. If you have not had much grilling experience, you should practice with pieces of meat such as rump steak or ribs, after which you can try your hand at fillet steak. For smaller pieces of meat, the grid iron must be very hot, otherwise the meat will dry out.

## **Veal**

Veal becomes dry very fast (also in foil). To protect the meat, you can wrap bacon around it. This will undermine its fine intrinsic taste, but the meat will remain juicy. Veal steaks taste good if cut from the back and grilled for just a short time, so that the meat is not too well-done. Then leave the meat to rest at 180°F/80°C in the oven.

## **Pork**

Streaky pork does not need a marinade or oil. Pieces of fillet, cutlets, roast pork and neck of pork are all suitable for grilling. Steaks and cutlets should be about 1 inch (2 cm) thick. Pork takes slightly longer to cook than other kinds of meat.

## **Lamb**

Lamb is ideal for grilling. It is more tender than beef, but not as tender as veal. Cutlets and pieces of shoulder are ideal. Lemon butter goes well with these. Preheat the plate and serve the piece of meat as hot as possible, the fat is difficult to digest when cold.

## **Poultry**

All kinds of poultry can be cooked on the grill. For guinea fowl, small pigeons and quail, it is better to brush a little fat onto the skin. Do not brush chicken with oil because they have enough fat under their skin. Poultry is seasoned inside and out before grilling.

## **Fish**

Salt water fish are no problem at all, whereas fresh water fish require a gentle approach because they have a tendency to fall apart. They are best prepared in aluminium foil, or brushed generously with a heat resistant oil.

## **Vegetables / potatoes**

Firm types of vegetables such as celery, chili peppers, aubergines, corn cobs, fennel or onions are ideal for grilling.

## **Fruit**

Apples, bananas, pears, pineapples and peaches all grill excellently.

## 7. Cleaning and care

**Note:** to avoid jeopardising the electrical safety of the appliance, do not use high-pressure or steam jet cleaning devices – risk of short circuits!

**Caution, risk of burns! Before cleaning, please wait until the appliance has cooled to hand-warm.**

Cleaning the grill after every use avoids residues burning in. If residues have burned in several times, they are difficult to remove.

Do not use scouring agents, abrasives or chemically aggressive cleaners (i.e. oven cleaner)! Do not use any nitro polishing agents for cleaning, or any abrasive sponges.

Use the included cleaning brush to clean the grid iron after every use.

Remove both grid irons. Tilt both grilling elements up and take off the lava stone container with the lava stones.

Clean the **grease collecting tray** in a dishwasher after removing food remnants.

Clean the **grid irons** with the cleaning brush or with dishwashing detergent and a dishwashing brush. Soak burnt-in residues in a little water and detergent. Please note: do not clean the grid irons in a dishwasher.

Clean the **stainless steel base and the work surface** with detergent and hot water. Soak stubborn residues with a little detergent solution. You can also clean the base with a stainless steel cleaner.

The **lava stones** must be replaced when they are black. In this case, the lava stones have become saturated with grease. Fat might ignite if too much fat has accumulated on the lava stones. You can order lava stones by quoting the order number LV 030-000.

Wash the **lava stone container** thoroughly with rinsing detergent and dry it. Pour the lava stones back into the lava stone container and tilt down the grilling elements. The grilling elements must lie flat.

To soak up fat on the **griddle plate**, sprinkle coarse salt onto the grilling surface after use. Mix the salt with the grease until it has become saturated with the grease. Remove the salt and wipe it away with a dry cloth. Soak burnt-in residues in a little water and detergent and clean with a dishwashing brush. Please note: do not clean the griddle plate in a dishwasher. It is advisable to rub the griddle plate with a little oil if it is not in use for a prolonged period of time.

Wipe the **control knobs** with a damp cloth. The cloth should not be too wet, as moisture could penetrate behind the control knob.

## 8. Maintenance

---

**The appliance must be disconnected from the power supply during all repair work.**

If the appliance does not function correctly, check the fuses first.

If the power supply is functioning correctly, but your appliance still does not work, please contact your **Gaggenau dealer** who will provide you with the address and telephone number of your nearest manufacturer's authorized service agent or contact **Gaggenau USA on (800) 828-9165**. Specify the appliance type (see rating plate).

**Repairs** may only be carried out by **authorised technicians**, in order to guarantee the safety of the appliance.

Unauthorised tampering with the appliance will void any warranty claims.

Only use original spare parts.

## 9. Installation

### Technical data

Total connected load: 3 000 W  
AC 208/220-240 V / 60 Hz

### Important notes on installation

This appliance can be combined with all Gaggenau Vario 400 Series appliances.

This appliance may be installed in kitchen combinations made of wood or similar combustible materials without taking additional safety measures. The built-in furniture and worktop where the appliance is installed must be heat resistant up to temperatures of 200°F/90°C.

The appliance must only be connected by an authorised specialist, paying attention to the relevant regulations of the power supply companies and the regional construction regulations.

When connecting electrical appliances in the proximity of cooking surfaces, make sure that connecting cables do not come into contact with hot cooking surfaces.

The installation technician is responsible for the correct functioning of the appliance at the place of installation. He must instruct the user on how to disconnect the appliance from electricity in an emergency.

After unpacking, check the appliance for any transportation damage and report this immediately to the transportation company.

Only install the grill with the appliance cover fitted. The appliance cover serves as a heat shield to the back wall during use.

There must be a gap of at least 12"/300 mm at the side between the appliance and any walls or furnishings.

**Note:** when installing a shelf, a distance of at least  $1\frac{3}{16}$ " (20 mm) from the bottom edge of the housing trough to the shelf or the next combustible item of furnishing is needed.

If all poles of the appliances cannot be isolated from the mains by removing an accessible plug, an isolating device with a contact gap of at least 3 mm must be installed (e.g. domestic fuse).

**No warranty claims can be considered for any damage resulting from failure to observe these instructions. Read the "Important notes" on page 3 and 4.**

**Subject to technical change without notice**

### Electrical connection

Only a qualified electrician should install this appliance.

**This appliance must be hardwired. The mains connecting cable must at least correspond to the type SJTO 3x16 AWG 105°C. The mains connecting cable must only be purchased through and connected by an authorised specialist. The appliance must be properly grounded. Read the information on the rating plate.**

## Preparing the cabinet

### Installation A

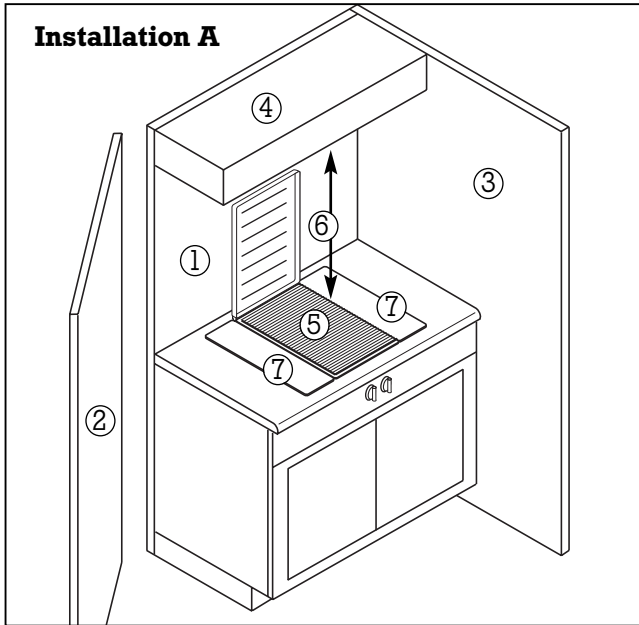

The building back wall (1) and building side walls (2 / 3) must consist of non combustible material or must be protected by no less than 1/4-inch-thick flame-retardant millboard covered with no less than No. 28 MSG sheet steel, 0.015-inch-thick stainless steel, 0.024-inch-thick aluminium, or 0.020-inch-thick copper.

- 1 Building back wall
- 2 Building side wall
- 3 Building side wall
- 4 Top building cabinet
- 5 Grilling surface
- 6 Distance = 30 inch (762 mm)
- 7 Work surface: Both work surfaces must be built-in on both sides, when the grill is built in separately (INSTALLATION A).

When installed next to another Vario appliance, a work surface must be built in on the opposite side (INSTALLATION B).

When the grill is installed between two other Vario appliances, no work surface is required (INSTALLATION C).

### Installation B

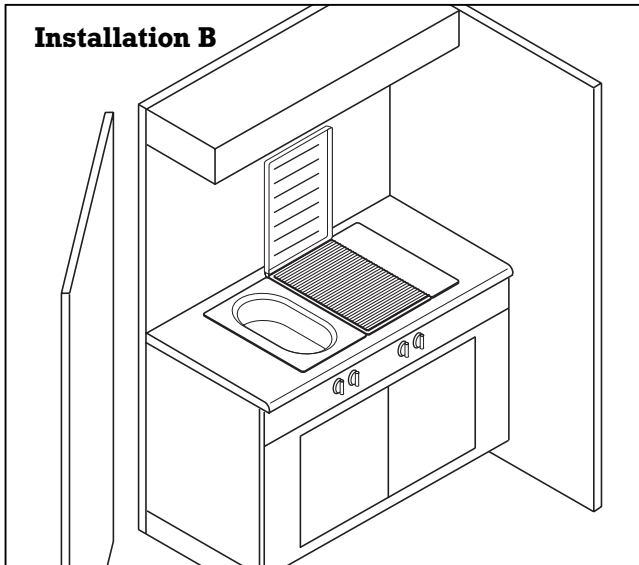

### Installation C

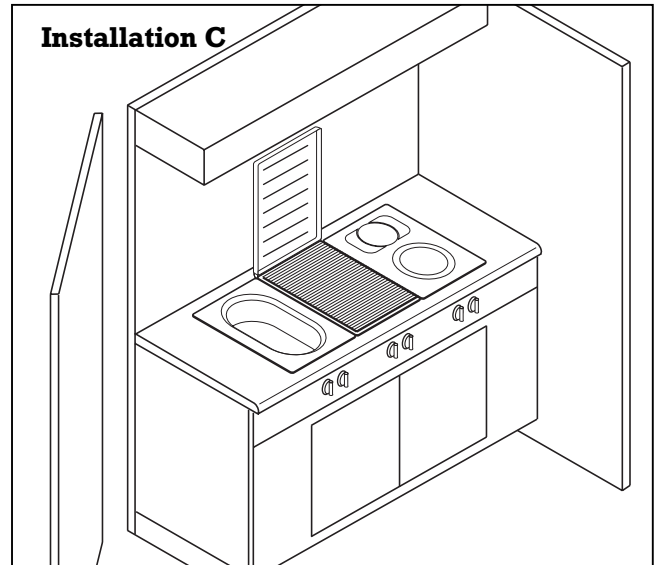

## Preparing the cabinet

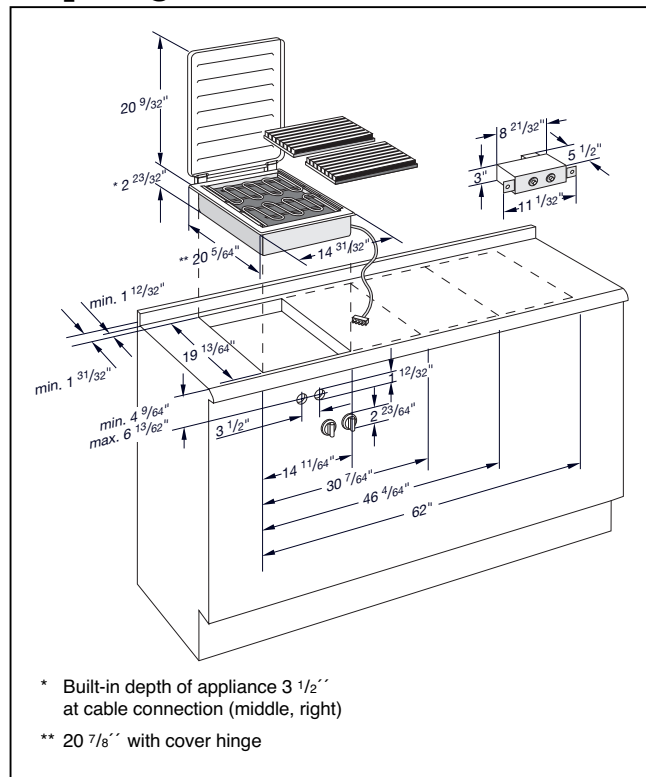

- Cut out the recess for one or several Vario appliances in your worktop. Proceed as indicated on the installation sketch. The installation sketch contains the measurements of the space required for the trim between the appliances. Several appliances can also be installed in individual recesses, as long as a minimum clearance of 50 mm (2") is kept to between the appliances.
- As shown in the installation sketch, drill the  $\text{Ø } 35 \text{ mm}$  ( $1\frac{3}{8}$ ") holes to secure the control knobs in the cabinet front.
- If the cabinet front is thicker than 26 mm ( $1\frac{1}{32}$ "), the front must be routed from the back to max. 26 mm ( $1\frac{1}{32}$ ") on an area of 80 x 310 mm ( $3\frac{5}{32}$ " -  $12\frac{13}{64}$ ").

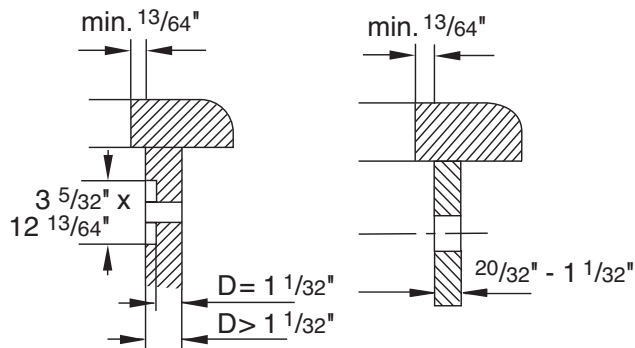

## Installing the control panel

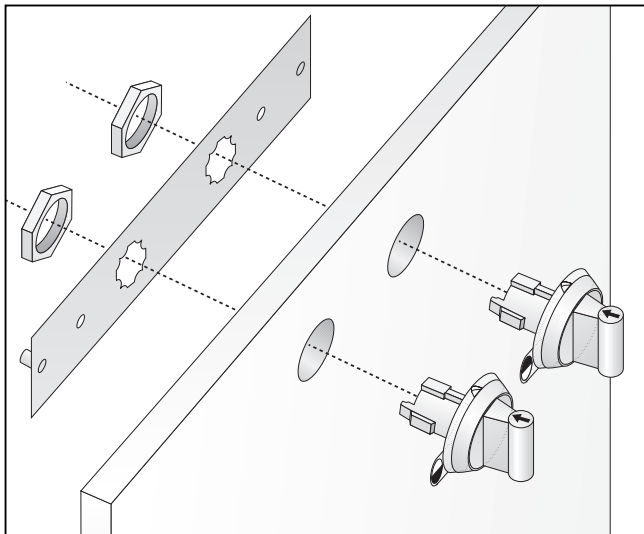

### Note:

only install control panel with appliance of the corresponding type.

- **Before connecting the grill, make sure the electricity is switched off at fuse point!**
- Before installation, remove all styrofoam packaging from the control knobs and peel off the protective film behind the luminous discs.
- Hold the support plate from the rear against the cabinet front, insert control knobs into the holes, secure from the rear with the nuts. Take care to install control knobs in the correct order: left for front grilling element, right for rear grilling element.
- Secure the control panel with the included nuts onto the support plate.

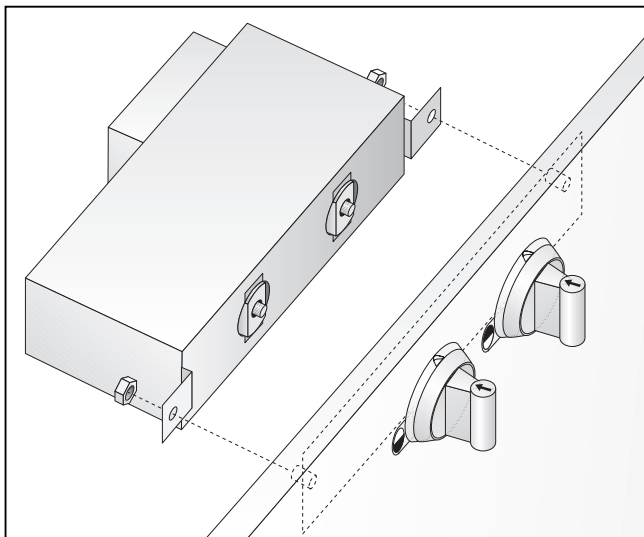

## Installing the grill

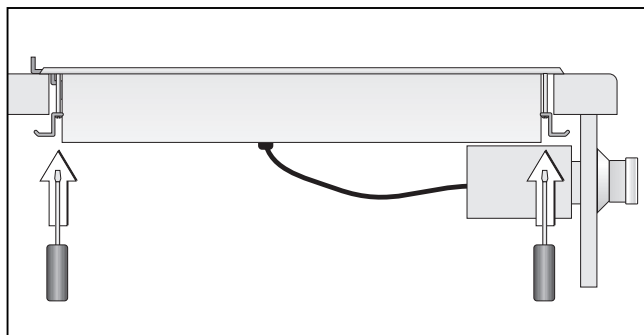
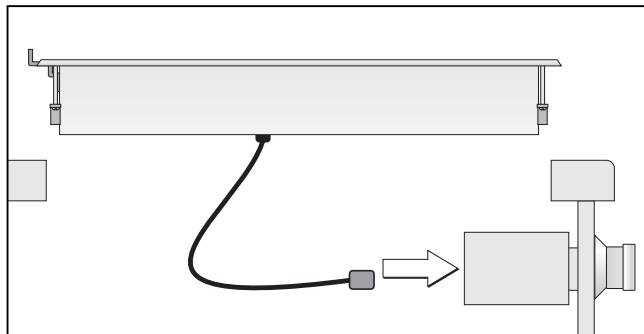

- Firmly plug the connecting cable in the grill and in the control panel (the plugs must lock into place).
- Turn the clamping screws to the side. Insert the grill with the control panel on the front into the cut-out and align it.  
**Note:** do not stick the grill onto the worktop with silicone.
- Turn the clamping screws under the countertop and tighten them evenly. Do not tighten the clamping screws too tightly, as a uniform sealing gap should be left all round.
- Stick the work surfaces onto the worktop with silicone.

**BOTH WORK SURFACES MUST BE BUILT-IN ON BOTH SIDES, WHEN THE GRILL IS BUILT IN SEPARATELY.**

**WHEN INSTALLED NEXT TO ANOTHER VARIO APPLIANCE A WORK SURFACE MUST BE BUILT IN ON THE OPPOSITE SIDE.**

**WHEN THE GRILL IS INSTALLED BETWEEN TWO OTHER VARIO APPLIANCES, NO WORK SURFACE IS REQUIRED.**

- Connect the appliance to the electricity. Test that it functions correctly. If the grill does not switch on, check the connecting cable between the grill and the control panel is firmly plugged in.

## Fitting the appliance cover

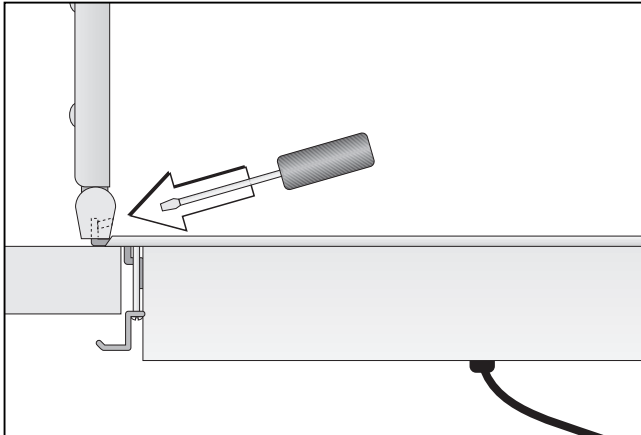

- The securing brackets are already fitted on the base.
- Place the appliance cover on the brackets in upright position and screw it down using the pre-mounted grub screws.
- Close the appliance cover. It must lie evenly on the appliance.
- If the cover is not fitted straight, loosen the sheet metal screws again and fit the included shims on the securing bracket until the appliance cover lies evenly on the panel edge.
- Again firmly screw down the appliance cover.

### **Note:**

do not use the appliance cover as a surface for placing objects or for keeping things warm. Wipe away spills before opening the appliance cover. Do not close the appliance cover until the appliance has cooled down completely. Do not operate the appliance with the cover closed! This may damage the appliance and the cover.



# **GAGGENAU**

GAGGENAU HAUSGERÄTE GMBH  
CARL-WERY-STR. 34 · 81739 MÜNCHEN  
GERMANY  
☎ (089) 45 90-03  
FAX (089) 45 90-23 47

# **GAGGENAU**

5551 McFADDEN AVENUE  
HUNTINGTON BEACH, CA 92649  
USA  
☎ (800) 828-9165 · FAX (714) 901-0979  
[www.gaggenau-usa.com](http://www.gaggenau-usa.com)