

Operating and Assembly Instructions

VP 421-610

Teppan Yaki



GAGGENAU

Important Safeguards	Page 3
1. Important Notes	Page 4-5
For your safety	Page 4
Operating for the first time	Page 5
About use	Page 5
2. Features	Page 6
Features	Page 6
Special accessories	Page 6
Operating principle	Page 6
3. Operation	Page 7-10
Switching on	Page 7
Switching off	Page 7
Residual heat display	Page 7
Keeping warm setting	Page 8
Holiday safeguard	Page 8
Visual signals	Page 9
Settings table	Page 10
4. Cleaning and care	Page 11
5. Maintenance	Page 12
6. Installation	Page 13-17
Technical data	Page 13
Important notes on installation	Page 13
Electrical connection	Page 13
Preparing the cabinet	Page 14-15
Installing the control panel	Page 16
Installing the appliance	Page 17

**Congratulations on buying your new
“Vario” appliance.**

Before switching your appliance on for the first time, we would like you to familiarize yourself with your new appliance. In this manual you will find important notes on safety and operation. These will serve to ensure your personal safety and the lasting value of your appliance.

You will find notes on Page 5 that you ought to observe before operating the appliance for the first time.

The chapters entitled “Features” and “Operation” tell you all about what your appliance can do and how you operate it.

The chapter entitled “Cleaning and care” gives tips on how to keep your appliance looking good.

And now we wish you lots of fun frying!

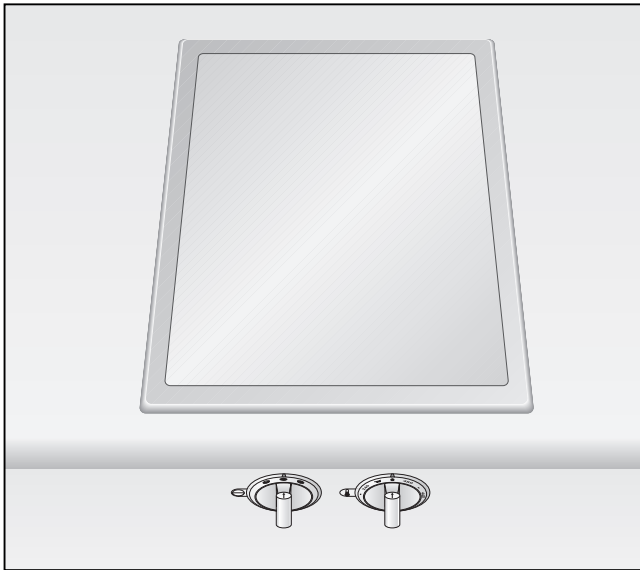

Important Safeguards

1. **Read All Instructions.**

2. To eliminate the risk of burns or fire by reaching over the heated surface units, cabinet storage space located above the surface units should be avoided.

3. **Important instructions**

- a) Ensure that this appliance is properly connected and grounded by a qualified electrician.
- b) Never use this appliance for warming or heating the room.
- c) Do Not Leave Children Alone – Children should not be left alone or unattended in area where appliances are in use. They should never be allowed to sit or stand on any part of the appliance.
- d) Wear Proper Apparel – Loose fitting or hanging garments should never be worn while using the appliance.
- e) User Servicing – Do not repair or replace any part of the appliance unless specifically recommended in the manual. All other servicing should be referred to a qualified technician.
- f) Storage in or on Appliance – Flammable materials should not be stored in an oven or near surface units.
- g) Do Not Use Water on Grease Fires – Smother fire or flame or use dry chemical or foam-type extinguisher.
- h) Use Only Dry Potholders – Moist or damp potholders on hot surface may result in burns from steam. Do not let potholders touch hot heating elements. Do not use a towel or other bulky cloth.

4. **DO NOT TOUCH HEATING ELEMENTS OR AREAS NEAR UNITS.** Heating elements may be hot even though they are dark in color. Areas near heating elements may become hot enough to cause burns. During and after use, do not touch or let clothing or other flammable materials contact heating elements or areas near units until they have had sufficient time to cool.

5. Never leave electric grill unattended when cooking, especially if using high settings.

6. **CAUTION:**

Do not store items of interest to children in cabinets above a range. Children climbing on the appliance to reach items could be seriously injured.

7. **Note** – To avoid jeopardising the electrical safety of the appliance, it is forbidden to use high-pressure or steam jet cleaning devices.

8. **Save These Instructions.**

1. Important Notes

For your safety

Do not operate the appliance if it is damaged.

The appliance must only be connected by an authorised specialist, paying attention to the relevant regulations of the power supply companies and the regional construction regulations.

Observe the assembly instructions!

When connecting electrical appliances in the proximity of the teppan yaki, make sure that connecting cables do not come into contact with hot cooking surfaces.

Only ever operate the appliance under supervision. Observe caution with oils and fats. Overheated oils and fats can easily cause fires.

Caution: the appliance heats up during operation. Keep children away.

To avoid jeopardising the electrical safety of the appliance, do not use high-pressure or steam jet cleaning devices.

Do not store any substances that are sensitive to high temperatures, or which pose a fire hazard (e.g. cleaning agents or spray cans), in drawers or cupboards under the appliance.

Isolate the appliance from the mains during every maintenance operation. To do this, remove the mains plug or switch off the corresponding fuse.

Repairs must be carried out by authorised specialists, thus ensuring electrical safety.

As the user, you are responsible for maintenance and proper use in the household. No warranty claims can be lodged for any damage resulting from failure to observe these instructions.

Note:

if you have fitted the appliance cover VD 400-000 (special accessory) on the appliance, it must not be closed until the appliance has cooled down completely. Do not operate the appliance with the cover closed! Heat development may damage the appliance and the cover. Do not use the appliance cover as a surface for placing objects or for keeping things warm.

Subject to technical change without notice.

Operating for the first time

Remove the packaging from the appliance and dispose of it according to local regulations. Be careful to remove all accessories from the packaging. Keep packaging elements and plastic bags away from children.

Check the appliance for transport damage before installing it.

The appliance must be installed and connected by an authorised specialist before operation. Before operating the appliance for the first time, make sure that the mains connection is in proper working order.

The serial number of the appliance can be found on the quality control slip which is included with these instructions. This quality control slip should be kept, for guarantee reasons, together with your operating and assembly instructions.

Read through these instructions attentively before operating your appliance for the first time.

Thoroughly clean the appliance and accessories before using them for the first time. Then heat up the appliance to 240 °C for a few minutes. This will eliminate any 'newness' smells and soiling.

About use

The appliance is intended solely for household use and must not be put to any other uses.

Only use the appliance to prepare meals directly on the frying surface – without pots or pans. Do not use the appliance to heat up the room in which it is installed.

Do not use the appliance to store items. Do not place any objects made out of plastic or with a plastic handle onto the hot frying surface.

The hard-chrome plated frying surface is tough, smooth and easy to clean. However, the surface will show signs of use after some time, just like a good cast iron pan. This does not interfere with the use of the appliance. Cutting directly on the frying surface is possible, however, we do not recommend it. The blade of the knife will become blunt. Do not cut with ceramic knives on the frying surface. Use the included spatulas to turn food.

Note: Do not hit the frying surface with a pointed knife or the spatula. This might leave marks on the surface.

Switch off the appliance after use. Allow the appliance to cool down and then clean. We recommend you clean the teppan yaki after every use.

Built-in overheating protection prevents overheating of the appliance and of surrounding kitchen furniture.

In the event of malfunction, first check your household fuses. If the power supply is in proper working order, but the appliance is still not functioning, please inform your specialist dealer or your nearest Gaggenau after-sales service.

2. Features

Features

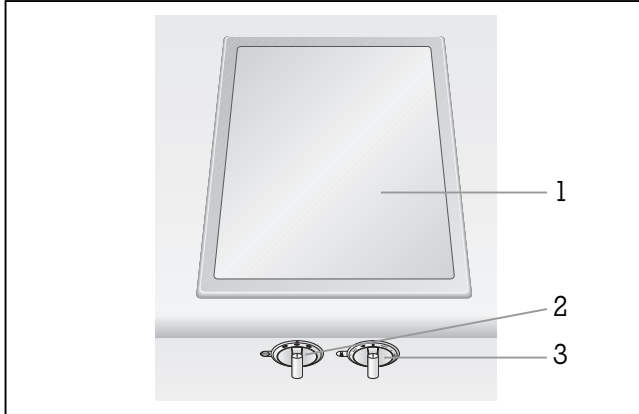

- 1 Frying surface, hard-chrome plated
- 2 Control knob for selecting the frying zone:
 - both heating zones selected
 - ◐ only front heating zone selected
 - ◑ only rear heating zone selected
- 3 Temperature control knob

2 spatulas are included to turn the food.

Special accessories

You can order the following special accessory:

- VV 400-000** Connecting trim
- VZ 400-700** Connecting trim with timer
- VD 400-000** Appliance cover

Operating principle

Teppan Yaki is an old Japanese tradition for grilling, frying and roasting. Preparing the food is an experience, the food is prepared – without pots or pans – directly on the frying surface. Use the included spatulas to turn the food and to remove food residues. The Teppan Yaki allows you to select the temperature that is best suited for the food. You can fry with little oil or fat on the smooth, hard-chrome plated surface, the food can be turned easily. The large frying area is ideally suitable for meat, fish, egg dishes, vegetables and sweet dishes.

3. Operation

Caution!

Frying produces very high temperatures. Keep children away!

Never switch on the appliance with the cover closed (special accessory).

Switching on

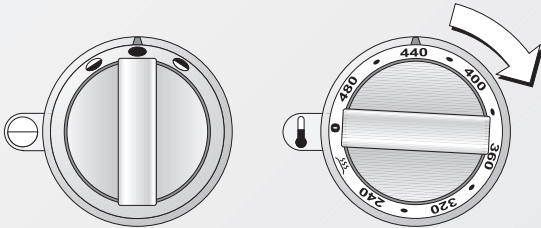

Switching on

Press down the left control knob and select the desired frying zone. You can select the whole frying zone, or only the front or rear part.

Press down the right control knob and turn it left or right to the required temperature between 240 - 480 °F

The luminous disc behind the right control knob flashes until the appliance heats up. When the correct temperature has been reached, the luminous disc lights constantly. Always preheat the appliance.

After heating up, coat the frying surface with a little oil or fat with the spatula or a heat-resistant brush (e.g. a silicone brush). Put the food directly – without pots or pans – on the frying surface. Use the included spatulas to turn the food.

Note: Do not hit the frying surface with the spatula. This might leave marks on the surface.

Switching off

Fully turn the right control knob to the OFF position.

Residual heat display

After switching the right control knob to the OFF position, the luminous disc behind the control knob will flash until the appliance has cooled down sufficiently to be touched safely.

Switching off

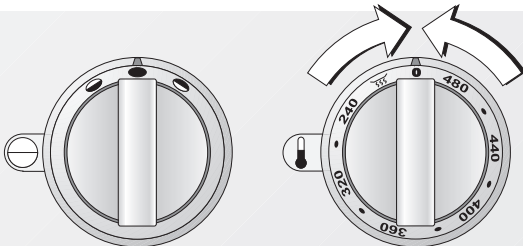

Caution! The appliance must not be touched until the residual heat display has gone off! **Risk of burns!**

Do not close the cover (special accessory) until the appliance has cooled down completely!

Keeping warm setting

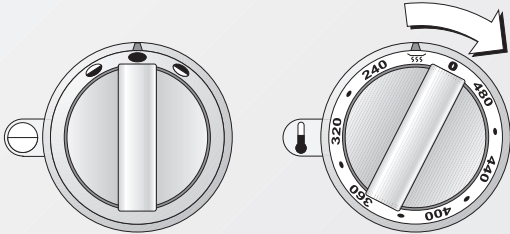

Keeping warm setting













Turn the right control knob to the keeping warm setting. Use the left control knob to select the desired heating zone. You can select the whole frying zone, or only the front or rear part.

The keeping warm setting enables you to keep food warm after frying.

Holiday safeguard (Automatic switch-off)

The appliance is set to automatically switch off 4 hours after the last operation. The luminous disc behind the right control knob flashes. Turn the right control knob to 0. Now the appliance can be switched on again as normal.

Visual signals

Luminous disc behind the left control knob	Luminous disc behind the right control knob	Signification	Cause / Remedy
	 lights OFF	appliance is switched OFF	
	 lights constantly	appliance is ON	normal use
	 slow flashing	appliance is ON, heating up	normal use
	 slow flashing	residual heat display	The appliance is too hot to be touched safely.
	 fast flashing	holiday safeguard	The appliance setting has not been changed for over 4 hours. Turn right control knob to 0 and then switch on again if required.
	 fast flashing	power cut	After a power cut, the appliance stays switched off for safety reasons. Turn control knob to 0 and then switch on again if required.

Settings table

Item	Temperature range	Examples
meats, poultry	sear at 480 °F* then roast at 360 - 440 °F	steaks, cutlets, fillets, medaillons, stir fry, lamb filets, chicken legs, turkey steaks, asian stir fry, meat skewers
fish	sear at 480 °F* then roast at 360 - 440 °F	swordfish slices, tuna steaks, salmon fillet, shrimps, squid, fish skewers
vegetable	440 - 480 °F	all kinds of small chopped hard vegetables, for example leeks, fennel, carrots, fried potatoes, mushrooms, chinese cabbage, soya seeds, peppers, beans, courgettes, aubergines
egg dishes	360 - 380 °F	fried egg, scrambled egg
sweet dishes	360 - 480 °F	crêpe, banana in coconut, apples, pineapples, mangoes

* roast thicker slices at 360 - 440 °F

Always preheat the appliance. The values specified here are guide values, which may differ depending on the condition and size of the food.

4. Cleaning and care

Note: to avoid jeopardising the electrical safety of the appliance, do not use high-pressure or steam jet cleaning devices – risk of short circuits!

Caution, risk of burns! Before cleaning, please wait until the appliance has cooled to hand-warm.

Cleaning the appliance after every use avoids residues burning in. After residues have burned in several times, they become difficult to remove.

Cleaning the frying area (hard chrome plated)

Remove food remnants with the spatula. Then pour $\frac{1}{2}$ pint warm soapy liquid onto the frying surface and allow to soak. Soak up the water with a sponge, then use a foam / plastic sponge to clean the frying surface. Always wipe in the direction of the brushed metal (horizontally), otherwise scouring marks might show on the frying surface.

Note: Do not use the scouring sponge to clean the stainless-steel frame, this will leave scratch marks. Do not use metal pot cleaners, steel wool, wire brush or similar. Do not use scouring agents, abrasives or chemically aggressive cleaners (for example oven cleaner, cleaner containing chloride, nitro polishing agents)!

Cleaning the stainless-steel frame

The frame of the appliance should be cleaned using a soft, damp cloth and light soapy liquid or a commercially available stainless steel cleaner. Do not use any abrasive and caustic cleaning agents.

Cleaning the control knobs

Wipe with a damp cloth. Cloth should not be too wet, as moisture could penetrate behind the control knob.

5. Maintenance

The appliance must be disconnected from the power supply during all repair work.

If the appliance does not function correctly, check the fuses first.

If the power supply is functioning correctly, but your appliance still does not work, please contact your **Gaggenau dealer** who will provide you with the address and telephone number of your nearest manufacturer's authorized service agent or contact **Gaggenau USA on (800) 828-9165**. Specify the appliance type (see rating plate).

Repairs may only be carried out by **authorised technicians**, in order to guarantee the safety of the appliance.

Unauthorised tampering with the appliance will invalidate any warranty claims.

Only ever use original spare parts.

6. Installation

Technical data

Total connected load: 1 500 W
AC 208/220-240 V / 60 Hz

Important notes on installation

This appliance can be combined with all Gaggenau Vario 400 Series appliances.

This appliance may be installed in kitchen combinations made of wood or similar combustible materials without taking additional safety measures. The built-in furniture and worktop where the appliance is installed must be heat resistant up to temperatures of 200°F/90°C.

The appliance must only be connected by an authorised specialist, paying attention to the relevant regulations of the power supply companies and the regional construction regulations.

When connecting electrical appliances in the proximity of cooking surfaces, make sure that connecting cables do not come into contact with hot cooking surfaces.

The installation technician is responsible for the correct functioning of the appliance at the place of installation. He must instruct the user on how to disconnect the appliance from electricity in an emergency.

After unpacking, check the appliance for any transportation damage and report this immediately to the transportation company.

Protection against accidental contact from below must be provided by an intermediate shelf that can only be removed with a tool. The distance from the top of the work surface to the top of the intermediate shelf must be at least 150 mm (6").

There must be a gap of at least 40 mm (1⁹/₁₆") at the side between the appliance and any walls or furnishings.

If all poles of the appliances cannot be isolated from the mains by removing an accessible plug, an isolating device with a contact gap of at least 3 mm must be installed (e.g. domestic fuse).

No warranty claims can be lodged for any damage resulting from failure to observe these instructions. Pay attention to the "Important notes" on page 3 and 4.

Subject to technical change without notice.

Electrical connection

Only a qualified electrician should install this appliance.

This appliance must be hardwired. The mains connecting cable must at least correspond to the type SJTO 3x16 AWG 105°C. The mains connecting cable must only be purchased through and connected by an authorised specialist. The appliance must be properly grounded. Pay attention to the information on the rating plate.

Preparing the cabinet

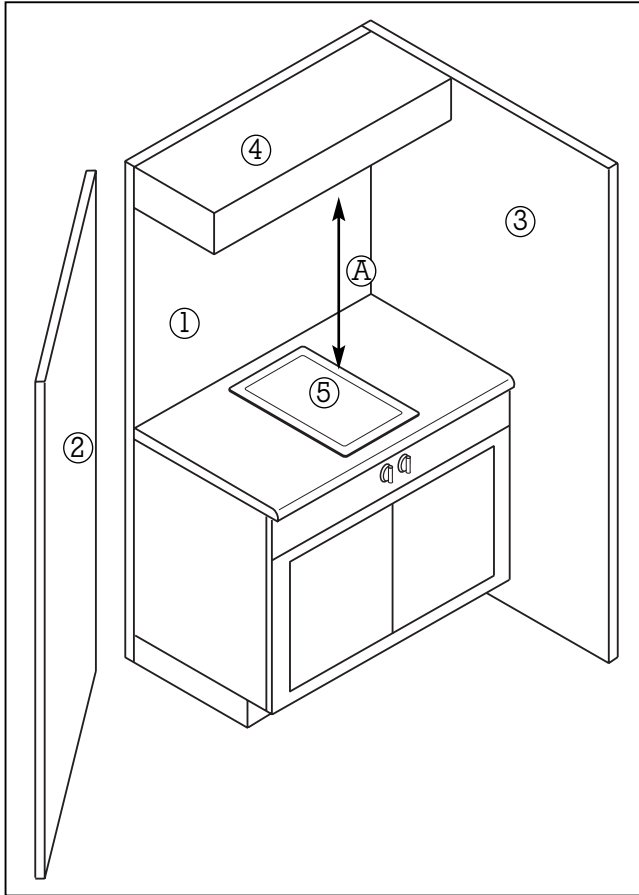

The building back wall (1) and building side walls (2 / 3) must consist of non combustible material or must be protected by no less than 1/4-inch-thick flame-retardant millboard covered with no less than No. 28 MSG sheet steel, 0.015-inch-thick stainless steel, 0.024-inch-thick aluminium, or 0.020-inch-thick copper.

- 1 Building back wall
 - 2 Building side wall
 - 3 Building side wall
 - 4 Top building cabinet
 - 5 Grilling surface
- A = 30 inch (762 mm)

Preparing the cabinet

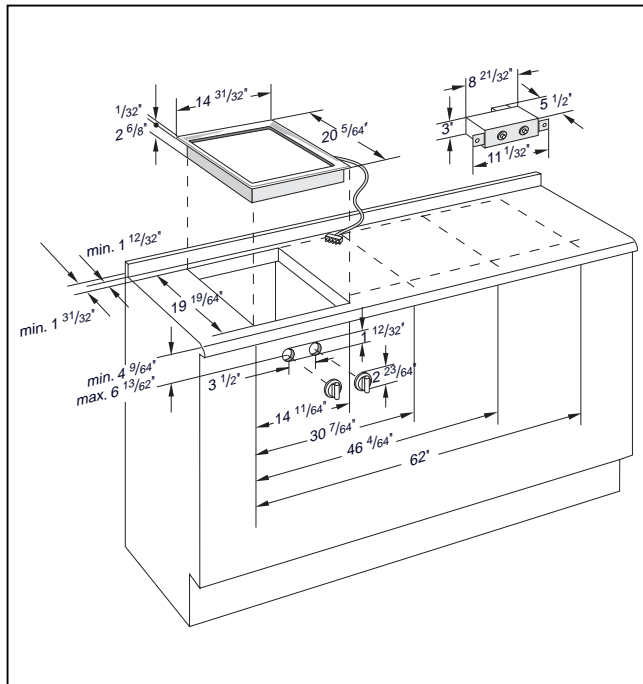

- Cut out the recess for one or several Vario appliances in your worktop. Proceed as indicated on the installation sketch. The installation sketch contains the measurements of the space required for the trim between the appliances. Several appliances can also be installed in individual recesses, as long as a minimum clearance of 50 mm (2") is kept to between the appliances.
- As shown in the installation sketch, drill the $\text{Ø } 35 \text{ mm}$ ($1\frac{3}{8}$ ") holes to secure the control knobs in the cabinet front.
- If the cabinet front is thicker than 26 mm ($1\frac{1}{32}$ "), the front must be routed from the back to max. 26 mm ($1\frac{1}{32}$ ") on an area of 80 x 310 mm ($3\frac{5}{32}$ " - $12\frac{13}{64}$ ").

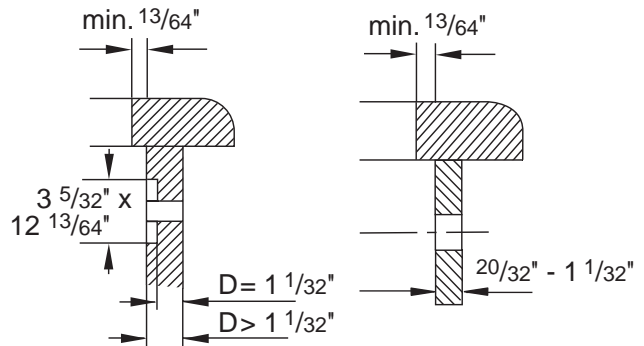

Installing the control panel

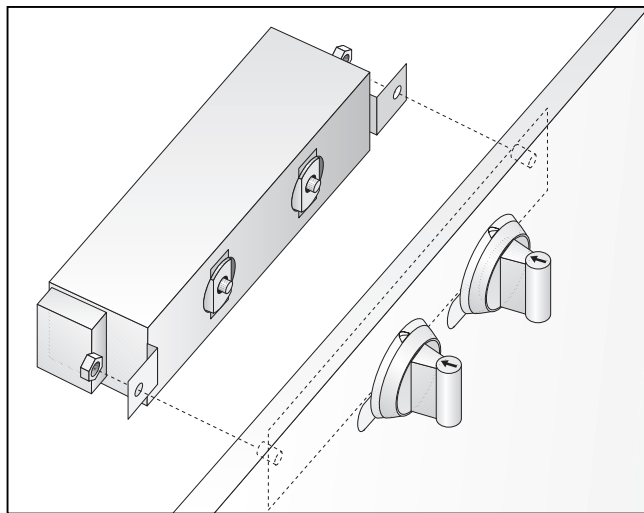
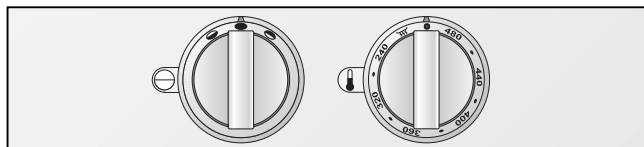
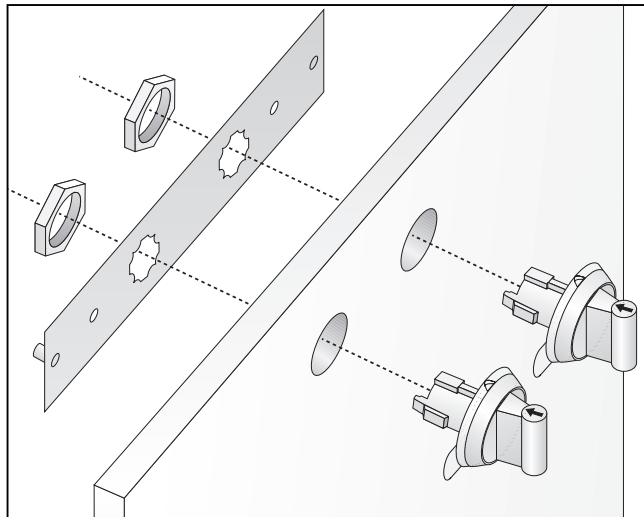

Note:

only install control panel with appliance of the corresponding type.

Before connecting the appliance, make sure the electricity is switched off at fuse point!

- Before installation, remove all styrofoam packaging from the control knobs and peel off the protective film behind the luminous discs.
- Hold the support plate from the rear against the cabinet front, insert control knobs into the holes, secure from the rear with the nuts. Take care to install control knobs in the correct order: left control knob for selecting the frying zone, right for temperature control knob.
- Secure the control panel with the included nuts onto the support plate.

Installing the appliance

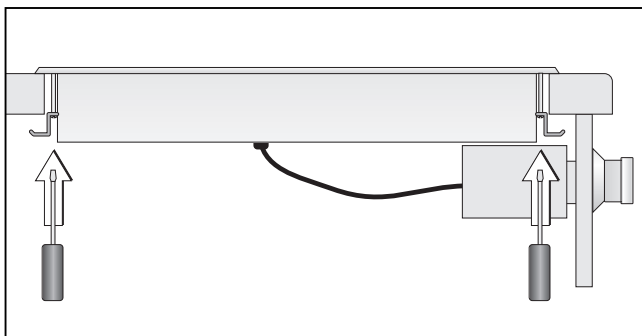
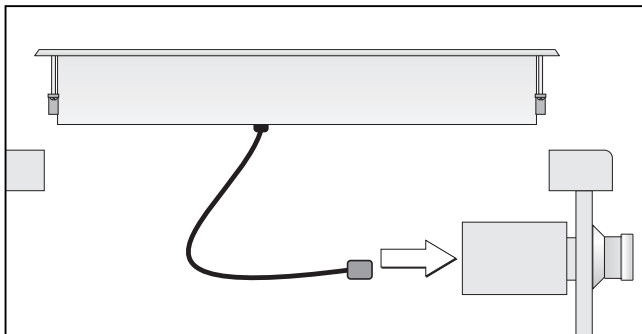

- Firmly plug the connecting cable in the appliance and in the control panel (the plugs must lock into place).
- Turn the clamping screws to the side. Insert the appliance with the control panel on the front into the cut-out and align it.
Note: do not stick the appliance onto the worktop with silicone.
- Turn the clamping screws under the countertop and tighten them evenly. Do not tighten the clamping screws too tightly, as a uniform sealing gap should be left all round.
- Connect the appliance to the electricity. Test that it functions correctly. If the appliance does not switch on, check the connecting cable between the appliance and the control panel is firmly plugged in.

GAGGENAU

GAGGENAU HAUSGERÄTE GMBH
CARL-WERY-STR. 34 · 81739 MÜNCHEN
GERMANY
☎ (089) 45 90-03
FAX (089) 45 90-23 47

GAGGENAU

5551 McFADDEN AVENUE
HUNTINGTON BEACH, CA 92649
USA
☎ (800) 828-9165 · FAX (714) 901-0979
www.gaggenau-usa.com