

SINGLE OVEN GAS RANGE

for residential use only



Models: **VEFSGG 365 ..**

- **USERS OPERATING INSTRUCTIONS**
IMPORTANT - PLEASE READ AND FOLLOW

IMPORTANT - PLEASE READ AND FOLLOW

- ✓ Before beginning, please read these instructions completely and carefully.
- ✓ Do not remove permanently affixed labels, warnings, or plates from the product. This may void the warranty.
- ✓ Please observe all local and national codes and ordinances.
- ✓ Please ensure that this product is properly grounded.
- ✓ **The installer should leave these instructions with the consumer who should retain for local inspector's use and for future reference.**
- ✓ The electrical plug should always be accessible.

Installation must conform with local codes or in the absence of codes, the National Fuel Gas Code ANSI Z223.1 - latest edition. Electrical installation must be in accordance with the National Electrical Code, ANSI/NFPA 70 - latest edition and/or local codes. IN CANADA: Installation must be in accordance with the current CAN/CGA-B149.1 National Gas Installation Code or CAN/CGA-B149.2, Propane Installation Code and/or local codes. Electrical installation must be in accordance with the current CSA C22.1 Canadian Electrical Codes Part 1 and/or local codes.

INSTALLATION IN MANUFACTURED (MOBILE) HOME: The installation must conform with the Manufactured Home Construction and Safety Standard, Title 24 CFR, Part 3280 [formerly the Federal Standard for Mobile Home Construction and Safety, Title 24, HUD (Part 280)] or, when such standard is not applicable, the Standard for Manufactured Home Installations, ANSI/NCSBCS A225.1, or with local codes where applicable.

INSTALLATION IN RECREATIONAL PARK TRAILERS: The installation must conform with state or other codes or, in the absence of such codes, with the Standard for Recreational Park Trailers, ANSI A119.5.

Installation of any gas-fired equipment should be made by a licensed plumber. A manual gas shut-off valve must be installed in the gas supply line ahead of the appliance in the gas stream for safety and ease of service.

If an external electrical source is utilized, the appliance, when installed, must be electrically grounded in accordance with local codes or, in the absence of local codes, with the national Electrical Code, ANSI/NFPA 70.

**This range is supplied with a protective film on steel and aluminium parts.
This film must be removed before installing/using the appliance.**

THIS RANGE IS FOR RESIDENTIAL USE ONLY



WARNING

- ALL RANGES CAN TIP
- INJURY TO PERSON COULD RESULT
- INSTALL ANTI-TIP DEVICE PACKED WITH RANGE
- SEE INSTALLATION INSTRUCTIONS



WARNING

NEVER use this appliance as a space heater to heat or warm the room. Doing so may result in carbon monoxide poisoning and overheating of the oven.

WARNING: IF THE INFORMATION IN THIS MANUAL IS NOT FOLLOWED EXACTLY, A FIRE OR EXPLOSION MAY RESULT CAUSING PROPERTY DAMAGE, PERSONAL INJURY, OR DEATH.

- ✓ Do not store or use gasoline or other flammable vapors and liquids in the vicinity of this or any other appliance.
- ✓ **WHAT TO DO IF YOU SMELL GAS:**
 - Do not try to light any appliance.
 - Do not touch any electrical switch; do not use any phone in your building.
 - Immediately call your gas supplier from a neighbor's phone. Follow the gas supplier's instructions.
 - If you cannot reach your gas supplier, call the fire department.
- ✓ Installation and service must be performed by a qualified installer, service agency, or the gas supplier.

Dear Customer,

Thank you for having purchased and given your preference to our product.

The safety precautions and recommendations reported below are for your own safety and that of others. They will also provide a means by which to make full use of the features offered by your appliance.

Please preserve this booklet carefully. It may be useful in future, either to yourself or to others in the event that doubts should arise relating to its operation.

This appliance must be used only for the task it has explicitly been designed for, that is for cooking foodstuffs. Any other form of usage is to be considered as inappropriate and therefore dangerous.

The manufacturer declines all responsibility in the event of damage caused by improper, incorrect or illogical use of the appliance.



WARNING!

The Governor of California is required to publish a list of substances known to the state of California to cause cancer or reproductive harm and requires businesses to warn customers of potential exposures to such substances.

WARNING!: Gas appliances contain or produce substances which can cause death or serious illness and which are known to the State of California to cause cancer, birth defects or other reproductive harm.

To reduce the risk from substances in fuel or from fuel combustion, make sure this appliance is installed, operated, and maintained according to the manufacturer's instructions.

This appliance is designed and manufactured solely for the cooking of domestic (household) food and is not suitable for any non-domestic application and therefore should not be used in a commercial environment.

The appliance guarantee will be void if the appliance is used within a non-domestic environment i.e. a semi-commercial, commercial or communal environment.

USER INSTRUCTIONS

GENERAL INFORMATION



WARNING!!

1. This appliance shall not be used for space heating. This information is based on safety considerations.
2. All openings in the wall behind the appliance and in the floor under the appliance shall be sealed.
3. Keep appliance area clear and free from combustible materials, gasoline, and other flammable vapors.
4. Do not obstruct the flow of combustion and ventilation air.
5. Disconnect the electrical supply to the appliance before servicing.
6. When removing appliance for cleaning and/or service;
 - A. Shut off gas at main supply.
 - B. Disconnect AC power supply.
 - C. Disconnect gas line to the inlet pipe.
 - D. Carefully remove the range by pulling outward.
CAUTION: Range is heavy; use care in handling.
7. **Electrical Requirement**
Electrical installation should comply with national and local codes.
8. **Air Supply and Ventilation**
The installer must refer to local/national codes.
9. **Gas Manifold Pressure**
Natural gas - 4.0" W.C.P.
LP/Propane - 11.0" W.C.P.
10. The misuse of oven door (e.g. stepping, sitting, or leaning on them) can result in potential hazards and/or injuries.
11. When installing or removing the range for service, a rolling lift jack should be used. Do not push against any of the edges of the range in an attempt to slide it into or out of the installation. Pushing or pulling a range (rather than using a lift jack) also increases the possibility of bending the leg spindles or the internal coupling connectors.



WARNING!!

ELECTRICAL GROUNDING INSTRUCTIONS

The range must be electrically grounded in accordance with local codes or, in the absence of local codes, with the National Electrical Code, ANSI/NFPA No. 70-latest edition. Installation should be made by a licensed electrician.

FOR PERSONAL SAFETY, THIS APPLIANCE MUST BE PROPERLY GROUNDED.

If an external electrical source is utilized, the installation must be electrically grounded in accordance with local codes or, in the absence of local codes, with the national Electrical Code, ANSI/NFPA 70.

This appliance is equipped with a three-prong grounding plug for your protection against shock hazard and should be plugged directly into a properly grounded socket.

Do not under any circumstances cut or remove the third (ground) prong from the power plug.

REPLACEMENT PARTS

Only authorized replacement parts may be used in performing service on the range. Replacement parts are available from factory authorized parts distributors. Contact the nearest parts distributor in your area.

IMPORTANT PRECAUTIONS AND RECOMMENDATIONS

After having unpacked the appliance, check to ensure that it is not damaged.

In case of doubt, do not use it and consult your supplier or a professionally qualified technician.

Packing elements (i.e. plastic bags, polystyrene foam, nails, packing straps, etc.) should not be left around within easy reach of children, as these may cause serious injuries.

The packaging material is recyclable and is marked with the recycling symbol .

- ✓ Do not attempt to modify the technical characteristics of the appliance as this may become dangerous to use.
- ✓ Do not carry out cleaning or maintenance operations on the appliance without having previously disconnected it from the electric power supply.
- ✓ After use, ensure that the knobs are in **OFF** position.
- ✓ Do not allow children or other incapable people to use the appliance without supervision.
- ✓ During and after use of the range, certain parts will become very hot. Do not touch hot parts.
- ✓ Keep children away from the range when it is in use.
- ✓ This range is supplied with a protective film on steel and aluminium parts. This film must be removed before installing/using the appliance.
- ✓ **Fire risk!** Do not store flammable material in the oven, and in the storage compartment.
- ✓ Make sure that electrical cables connecting other appliances in the proximity of the range cannot come into contact with the hob or become entrapped in the oven door.
- ✓ Do not line the oven walls with aluminium foil. Do not place shelves, broiler pan, pans or other cooking utensils on the base of the oven chamber.
- ✓ The manufacturer declines all liability for injury to persons or damage to property caused by incorrect or improper use of the appliance.
- ✓ To avoid any possible hazard, the appliance must be installed by qualified personnel only. Any repairs by unqualified persons may result in electric shock or short circuit. In order to avoid possible injuries to your body or to the appliance, do not attempt any repairs by yourself. Such work should be carried out by qualified service personnel only.
- ✓ **Danger of burns!** The oven and cooking accessories may become very hot during operation. Make sure children are kept out of reach and warn them accordingly. To avoid burns use kitchen clothes and gloves when handling hot parts or utensils.
- ✓ Stand away from the range when opening oven door. Hot air or steam which escapes can cause burns to hands, face, and/or eyes.
- ✓ Never clean the range, oven and storage compartment with a high-pressure steam cleaning device, as it may provoke a short circuit.
- ✓ This appliance is intended for use in your household. Never use the appliance for any other purpose!
- ✓ If you should decide not to use this appliance any longer (or decide to substitute an older model), before disposing of it, it is recommended that it be made inoperative in an appropriate manner in accordance to health and environmental protection regulations, ensuring in particular that all potentially hazardous parts be made harmless, especially in relation to children who could play with old appliances.
Remove the door and the storage compartment pivoting panel before disposal to prevent entrapment.

IMPORTANT PRECAUTIONS AND RECOMMENDATIONS FOR USE OF ELECTRICAL APPLIANCES

Use of any electrical appliance implies the necessity to follow a series of fundamental rules. In particular:

- ✓ Never touch the appliance with wet hands or feet;
- ✓ Do not operate the appliance barefooted;
- ✓ Do not allow children or disabled people to use the appliance without your supervision.

The manufacturer cannot be held responsible for any damages caused by improper, incorrect or unreasonable use of the appliance.

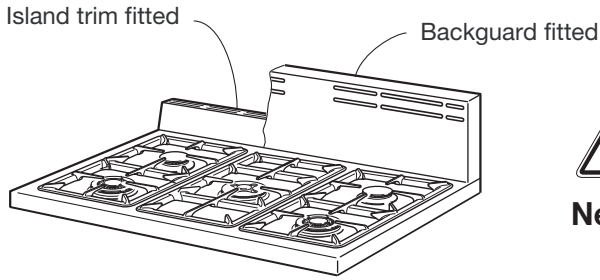

WARNING - VERY IMPORTANT NOTICE



Never obstruct the slots on the backguard / island trim.

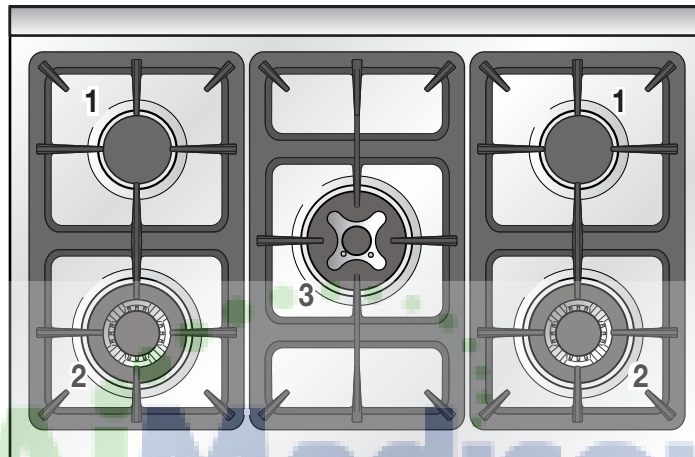

Fig. 1.1

AJ Madison
Your Appliance Authority™

800-570-3355

COOKING HOB

- 1. Semi-rapid burner (SR) - 6000 BTU/hr
- 2. Triple-ring burner (TR) - 12000 BTU/hr
- 3. Dual burner (D) - 16000 BTU/hr (Natural gas),
15000 BTU/hr (LP/Propane)

Note:

- The electric gas-lighting device is incorporated into the knobs.
- The appliance has a safety valve system fitted, the flow of gas will be stopped if and when the flame should accidentally go out.

CAUTION:

If the burner is accidentally extinguished, turn the gas off at the control knob and wait at least 1 minute before attempting to relight.

CAUTION:

Gas appliances produce heat and humidity in the environment in which they are installed. Ensure that the cooking area is well ventilated following national/local codes.



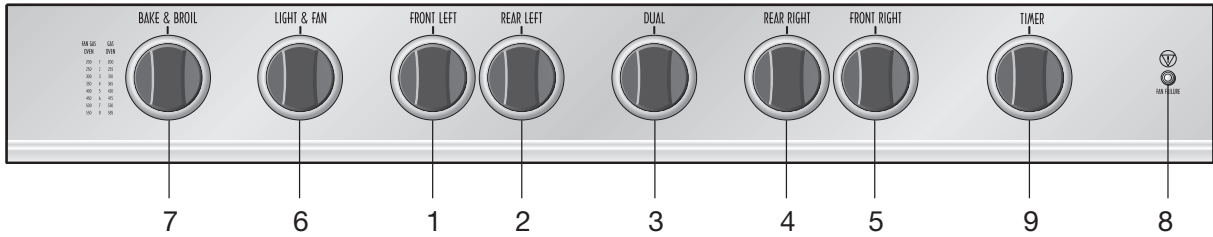



Fig. 1.2



CONTROLS DESCRIPTION

- 1. Front left burner (2) control knob
- 2. Rear left burner (1) control knob
- 3. Central dual burner (3) control knob
- 4. Rear right burner (1) control knob
- 5. Front right burner (2) control knob
- 6. Oven light & fan control knob
- 7. Gas oven/gas broil control knob
- 8. Cooling fan failure warning light
- 9. 60' alarm knob



 WARNING  COOLING FAN WARNING LIGHT <u>VERY IMPORTANT NOTICE</u>		
  FAN FAILURE	<p>When the cooling fan failure warning light is OFF the cooling fan motor is correctly operating.</p> <p>The burners of the cooking hob and the gas oven can be used.</p>	<p>Operate the cooking hob burners and the oven as per instruction manual.</p>
 FAN FAILURE	<p>When the cooling fan failure warning light is lighted this indicates the malfunctioning of the cooling fan motor.</p> <p>The gas oven cannot be used.</p> <p>Only the burners of the cooking hob can be used.</p>	<p>Contact the After-Sales Service.</p> 

how to use the top burners

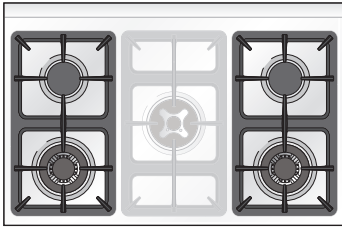

GAS BURNERS (Semi-rapid and triple ring)

Gas flow to the burners is adjusted by turning the knobs (illustrated in fig. 2.1) which control the valves.

Turning the knob so that the symbols printed on itself point to the symbol printed on the control panel achieves the following functions:

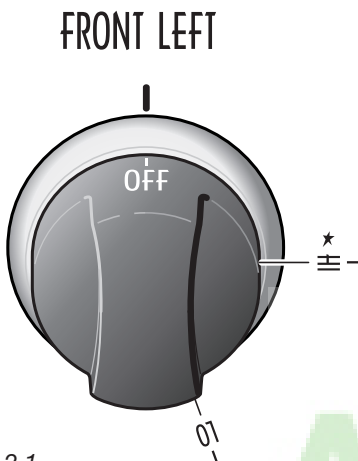

Fig. 2.1

Knob position	Function	SEMI-RAPID burner	TRIPLE RING burner
OFF	closed valve		
★ HI	maximum rate		
LO	minimum rate		

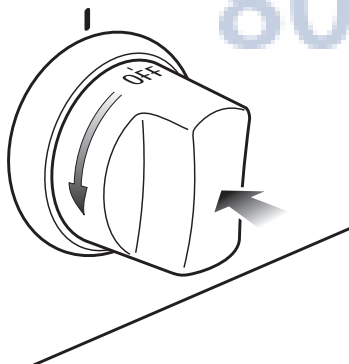

Fig. 2.2

The maximum aperture position permits rapid boiling of liquids, whereas the minimum aperture position allows simmer warming of food or maintaining boiling conditions of liquids.

To reduce the gas flow to minimum, rotate the knob further anti-clockwise to point the indicator towards the **LO** position.

Other intermediate operating adjustments can be achieved by positioning the indicator between the maximum and minimum aperture positions, and never between the maximum aperture and **OFF** positions.

N.B. When the range is not being used, set the gas knobs to their **OFF** positions and also close the gas shut-off valve placed on the main gas supply line.

LIGHTING GAS BURNERS FITTED WITH FLAME FAILURE SAFETY DEVICE (Semi-rapid and triple ring)

In order to light the burner, you must:

- 1 – Push and turn the knob in an anti-clockwise direction up to the **★ HI** position (maximum rate), push in and hold the knob until the flame has been lit (fig. 2.2).
The sparks produced by the lighter situated inside the relative burner will light the flame.
In the event that the local gas supply conditions makes it difficult to light the burner in **★ HI** position, try again with the knob in **LO** position.
If there is no mains electrical supply, bring a lighted match close to the burner.
- 2 – Wait for about ten seconds after the gas burner has been lit before letting go the knob (safety device activation delay).
- 3 – Adjust the gas valve to the desired position.

If the burner flame should go out for some reason, the safety valve will automatically stop the gas flow.

To re-light the burner, return the knob to the closed **OFF** position, **wait for at least 1 minute** and then repeat the lighting procedure.

If your local gas supply makes it difficult to light the burner with the knob set to maximum, set the knob to minimum and repeat the operation.

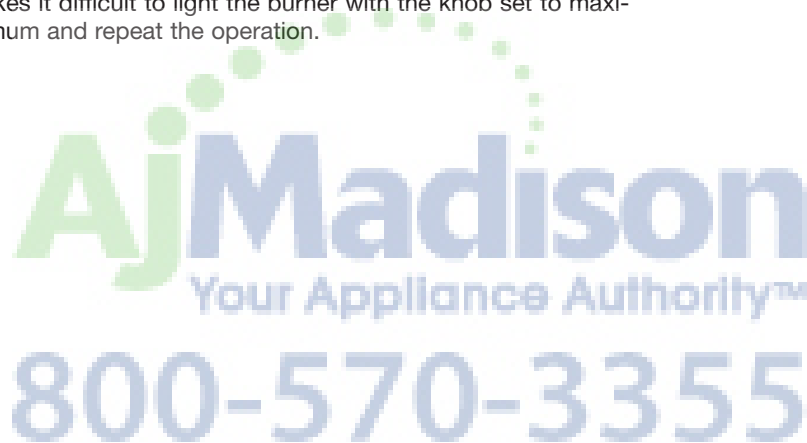

Caution!

**The range becomes very hot during operation.
Keep children well out of reach.**

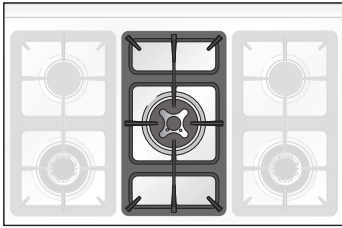

GAS BURNERS (Dual)

The Dual Burner is a very flexible burner which allows different regulations and optimal cooking.

It is composed by one inner and two outer crowns; the flame of the inner crown can be regulated separately from the flames of the outer crowns.

The Dual Burner can be used:

- as a small burner (flame produced only by the inner crown) which can be adjusted from the maximum (* HI) to the minimum (SIM) position. Intermediate operating adjustments can be achieved by positioning the indicator between the maximum and minimum opening positions, and never between the maximum opening and OFF position.
- as a high-power burner (all flames produced simultaneously by inner and outer crowns) which can be adjusted from the maximum (HI) to the minimum (LO) position.

Gas flow to the burner is adjusted by turning the knob (illustrated in fig. 2.3) which controls the valve.

Turning the knob so that the symbols printed on itself point to the symbol printed on the control panel achieves the following functions:

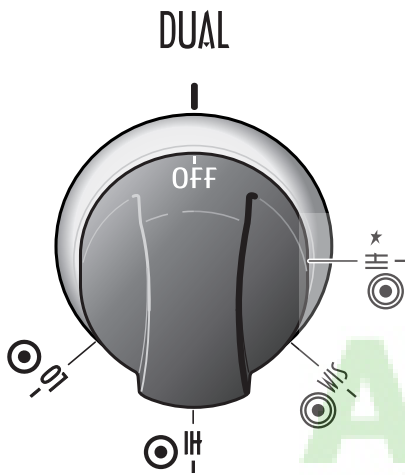

Fig. 2.3

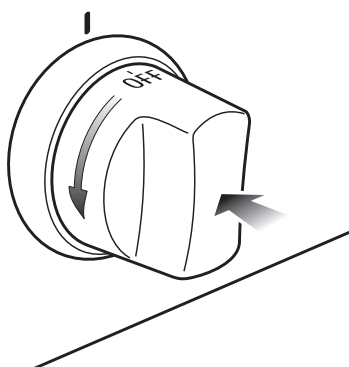





Fig. 2.4

Knob position	Function	DUAL burner
OFF	closed valve	
* HI	maximum rate of inner crown (only inner flame at the maximum)	
SIM	minimum rate of inner crown (only inner flame at the minimum)	
HI	maximum rate of inner + outer crowns (inside and outside flames in simultaneously at the maximum)	
LO	minimum rate of inner + outer crowns (inside and outside flames in simultaneously at the minimum)	

AjMadison
Your Appliance Authority™
800-570-3355

LIGHTING GAS BURNERS FITTED WITH FLAME FAILURE SAFETY DEVICE (Dual Burner)

In order to light the burner, you must:

- 1 – Push and turn the knob in an anti-clockwise (fig. 2.4) direction up to the  position (maximum rate of inner crown); push in and hold the knob until the flame has been lit.
The sparks produced by the lighter situated inside the relative burner will light the flame.
In the event that the local gas supply conditions makes it difficult to light the burner in  position, try again with the knob in  position.
If there is no mains electrical supply connection, bring a lighted match close to the burner.
- 2 – Wait for about ten seconds after the gas burner has been lit before letting go the knob (safety device activation delay).
- 2 – Adjust the gas valve to the desired position.

If the burner flame should go out for some reason, the safety valve will automatically stop the gas flow.

To re-light the burner, return the knob to the closed position (**OFF**), wait for at least 1 minute and then repeat the lighting procedure.

N.B. When the range is not being used, set the gas knobs to their **OFF** positions and also close the gas shut-off valve placed on the main gas supply line.

CAUTION!

The range becomes very hot during operation. Keep children well out of reach.

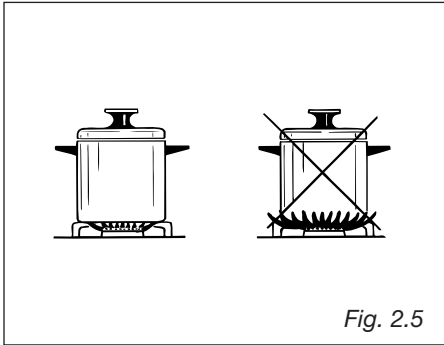

CHOICE OF BURNER (fig. 2.5)

The symbols printed on the panel above the gas knobs indicate the correspondence between the knob and the burner.

The most suitable burner is to be chosen according to the diameter and volume capacity of the container to be warmed.

It is important that the diameter of the pots or pans suitably match the heating potential of the burners in order not to jeopardise the efficiency of the burners, bringing about a waste of gas fuel.

A small diameter pot or pan placed on a large burner does not necessarily mean that boiling conditions are reached quicker.

DIAMETERS OF PANS WHICH MAY BE USED ON THE HOB BURNERS		
BURNER	MINIMUM	MAXIMUM
Semi-rapid	16 cm (6" 19/64)	24 cm (9" 7/16)
Triple-ring	26 cm (10" 3/16)	28 cm (11" 1/16)
Dual	26 cm (10" 3/16)	28 cm (11" 1/16)
Wok pans max 36 cm (14" 3/16)		
Do not use pans with concave or convex bases		

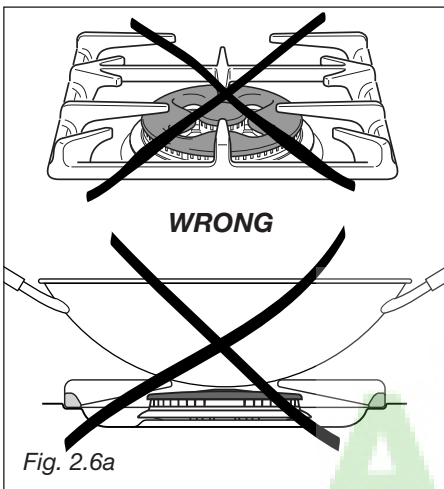

CORRECT USE OF DUAL BURNER (Fig. 2.6a - 2.6b)

The flat-bottomed pans are to be placed directly onto the pan-support.

When using a WOK you need to place the supplied stand in the burner to avoid any faulty operation of the dual burner (Figs. 2.6a - 2.6b).

IMPORTANT:

The special grille for wok pans (fig. 2.6b) **MUST BE PLACED ONLY** over the pan-rest for the dual burner.

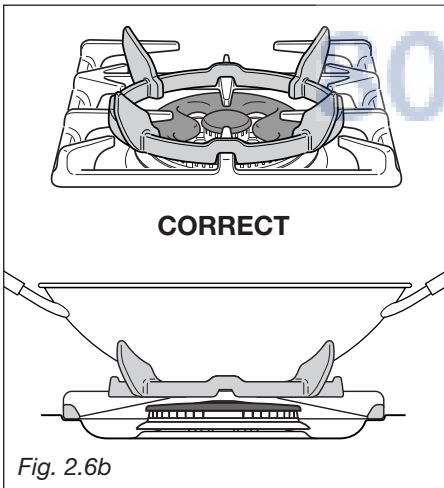

Aj Madison
00-570-3355



Make sure that the handles of cookware do not stick out over the edge of the range, to avoid them being knocked over by accident. This also makes it more difficult for children to reach the cooking vessels.

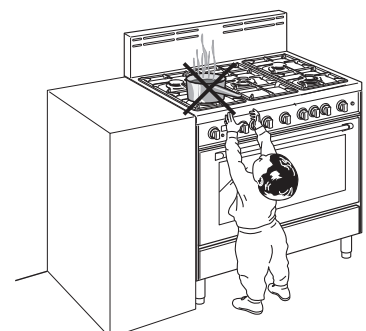

GENERAL FEATURES

The gas oven is provided with:

- a) Oven burner, mounted on the lower part of the oven (21000 BTU/hr).
- b) Broil burner, mounted on the upper part of the oven (15000 BTU/hr).
- c) Fan motor which can be used in combination with the oven burner or separately (without heating). **It is not possible to use the fan motor in combination with the broil burner: a safety device switches off the fan motor when the gas oven/broil control knob is turned on broil position.**
- d) Light that illuminates the oven to enable visually controlling the food that is cooking.

Attention: the range becomes very hot during operation.

Attention: the oven door becomes very hot during operation.

Keep children away.

WARNING:
The door is hot, use the handle.

OPERATING PRINCIPLES

Heating and cooking are obtained in the following ways:

- a. **by normal convection**
The heat is produced by the oven burner.
- c. **by forced convection**
The heat produced by the oven burner is distributed throughout the oven by the fan. The hot air envelops the food in the oven, provoking a complete and rapid cooking.
It is possible to cook several dishes simultaneously.
- d. **by radiation**
The heat is irradiated by the infra red broil burner.
- f. **by ventilation** (this is not a cooking function)
The food is defrosted by using the fan only without oven burner.

N.B. When the range is not being used, set the gas knobs to their **OFF** positions and also close the gas shut-off valve placed on the main gas supply line.

VERY IMPORTANT

The oven/broil shall be used always with the oven door closed.

USING THE OVEN FOR THE FIRST TIME

It is advised to follow these instructions:

- Furnish the interior of the oven by placing the wire racks as described at chapter "Cleaning and maintenance".
- Insert shelves and tray.
- Turn the oven on to the maximum temperature (position 8 ★) to eliminate possible traces of grease from the oven burner. The same operation should be followed for broil burner.
- Switch off the electrical supply, let the oven cool down, then clean the interior of the oven with cloth soaked in water and detergent (neutral) then dry carefully.

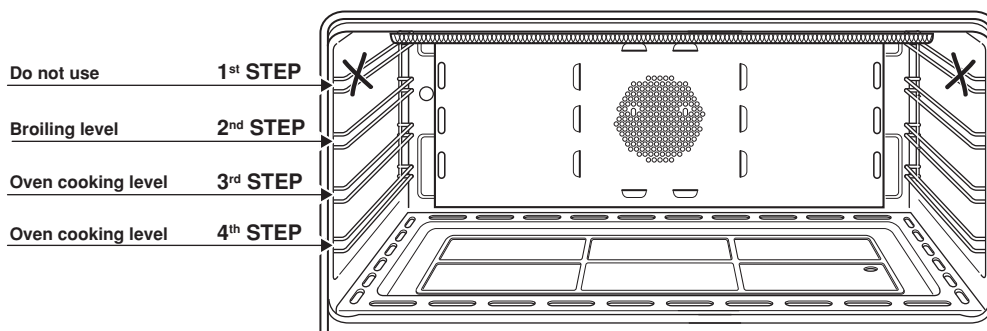

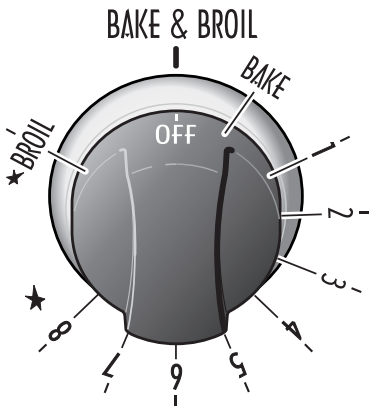

Fig. 3.1

FAN GAS OVEN		GAS OVEN
200	1	200
250	2	255
300	3	310
350	4	365
400	5	420
450	6	475
500	7	525
550	8	575

OVEN BURNER

It carries out normal “oven cooking”.

The gas flow to the burner is regulated by a thermostat which allow to maintain the oven temperature constant.

The control of the temperature is assured by a thermostatic probe positioned inside the oven.

The probe must be always kept in its housing, in a clean condition, as an incorrect position or encrustment may cause an alteration in the control of the temperature.

OVEN THERMOSTAT

The numbers printed on the control knob (fig. 3.1) indicate the increasing oven temperature value (see temperature table near the control knob - fig. 3.1).

Left column of the temperature table refers to oven burner used in combination with the fan motor while right column refers to oven burner used in the normal convection mode (without fan motor).

To regulate the temperature, set the chosen number onto the control panel indicator.

The position ★**BROIL** serves only to turn on the broil burner.

OVEN LIGHT AND FAN MOTOR

The oven light and the fan motor are controlled by a switch knob on the control panel (fig. 3.2). To light up the oven lamp turn the knob anti-clockwise to **LIGHT** position.

To operate the fan motor turn the knob clockwise to **LIGHT & FAN** position.

In this setting also the oven lamp is lighted.

WARNING: The switch knob can be turned only clockwise from **OFF** to **LIGHT & FAN** position and anti-clockwise from **OFF** to **LIGHT** position.

The switch knob **DO NOT TURN** from **LIGHT & FAN** to **LIGHT** position. **DO NOT FORCE.**

IMPORTANT NOTE: The fan motor can be used in combination only with the oven burner. A safety device switches off the fan motor when the gas oven/broil control knob is turned on ★**BROIL** position.

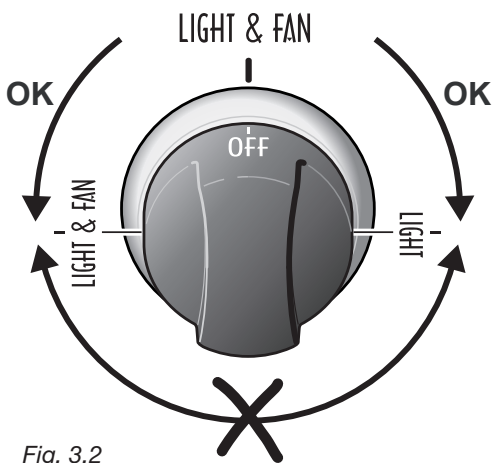

Fig. 3.2

IGNITION OF THE OVEN BURNER

IMPORTANT NOTE: during ignition of the oven burner the fan motor shall be switched off (light and fan control knob in **OFF** position - Fig. 3.2).

The thermostat allows the automatic control of the temperature.

The gas delivery to the oven burner is controlled by a two way thermostatic tap (oven and broil burners) with flame-failure device.

To light the oven burner operate as follows:

1) Open the oven door to its full extent.

WARNING: Risk of explosion! The oven door must be open during this operation.

2) Press the oven control knob right down and, keeping it pressed, turn counter-clockwise (fig. 3.3) to max position **8** ★ .

3) Release the knob and check the oven burner has lit; if not, turn the knob clockwise back to OFF and repeat the procedure from step 2.

4) Once the oven burner has lit, close the oven door slowly and adjust the burner according to the power required.

If the flame extinguishes for any reason, the safety valve will automatically shut off the gas supply to the burner.

To re-light the burner, first turn the oven control knob to position **OFF**, wait for at least **1 minute and then repeat the lighting procedure.**

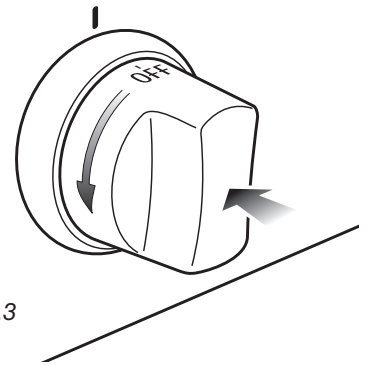

Fig. 3.3

Attention: the oven door becomes very hot during operation. Keep children away.

TRADITIONAL BAKING (OVEN BURNER WITHOUT FAN MOTOR)

Before introducing the food, preheat the oven to the desired temperature.

For a correct preheating operation, it is advisable to remove the tray from the oven and introduce it together with the food, when the oven has reached the desired temperature.

Check the cooking time and turn off the oven 5 minutes before the theoretical time to recuperate the stored heat.

Recommended for:

For foods which require the same cooking temperature both internally and externally, i.e. roasts, spare ribs, meringue, etc.

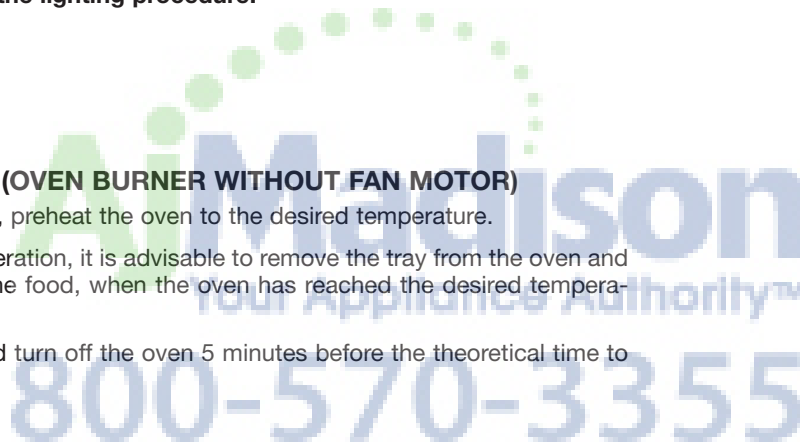
 AiMedison
 Your Appliances Authority™
 800-570-3355

CONVECTION BAKING WITH VENTILATION (OVEN BURNER WITH FAN MOTOR)

After lighting the oven burner switch on the fan motor by turning the LIGHT & FAN control knob (fig. 3.2) on LIGHT & FAN position.

Before introducing the food, preheat the oven to the desired temperature.

For a correct preheating operation, it is advisable to remove the tray from the oven and introduce it together with the food, when the oven has reached the desired temperature.

Check the cooking time and turn off the oven 5 minutes before the theoretical time to recuperate the stored heat.

It is possible to cook various different foods at the same time. Fish, cakes and meat can be cooked together without the smells and flavours mixing.

The only precautions required are the following:

- The cooking temperatures must be as close as possible with a maximum difference of 70-80 °F (20-25 °C) between the different foods.
- Different dishes must be placed in the oven at different times according to the cooking time required for each one. This type of cooking obviously provides a considerable saving on time and energy.

Recommended for:

For foods of large volume and quantity which require the same internal and external degree of cooking; for ex: rolled roasts, turkey, legs, cakes, etc.

DEFROSTING FROZEN FOODS (ONLY FAN MOTOR)

With the oven burner control knob in OFF position turn the LIGHT & FAN control knob (fig. 3.2) on LIGHT & FAN position.

Only the fan and the oven lamp switch on. Defrosting takes place by the fan, without heating.

Recommended for:

To rapidly defrost frozen foods; 2.2 lbs (1 kg) requires about one hour.

The defrosting times vary according to the quantity and type of foods to be defrosted.

AjMadison
Your Appliance Authority
800-570-3355

IGNITION OF THE BROIL BURNER

IMPORTANT NOTE: the fan motor cannot be used in combination with the broil burner. A safety device switches off the fan motor when the gas oven/broil control knob is turned on ★ **BROIL** position.

The broil burner generates the infra-red rays for broiling.

To light the broil burner operate as follow:

1) Open the oven door to the full extent.

WARNING: Risk of explosion! The oven door must be open during this operation.

2) Press the oven control knob right down and, keeping it pressed, turn clockwise (fig. 3.4) to the ★ **BROIL** position.

3) Release the knob and check the broil burner has lit; if not, turn the knob counterclockwise back to **OFF** and repeat the procedure from step 2.

4) Once the broil burner has lit, close the oven door slowly.

If the flame extinguishes for any reason, the safety valve will automatically shut off the gas supply to the burner.

To re-light the burner, first turn the oven control knob to position **OFF**, wait for at least 1 minute and then repeat the lighting procedure.

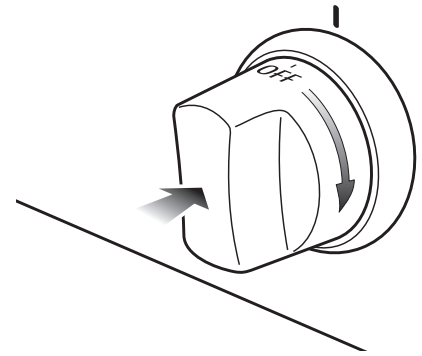

Fig. 3.4

Do always broil with oven door closed.

Attention: the oven door becomes very hot during operation.

Keep children away.

AiMadison
Your Appliance Authority™
800-570-3355

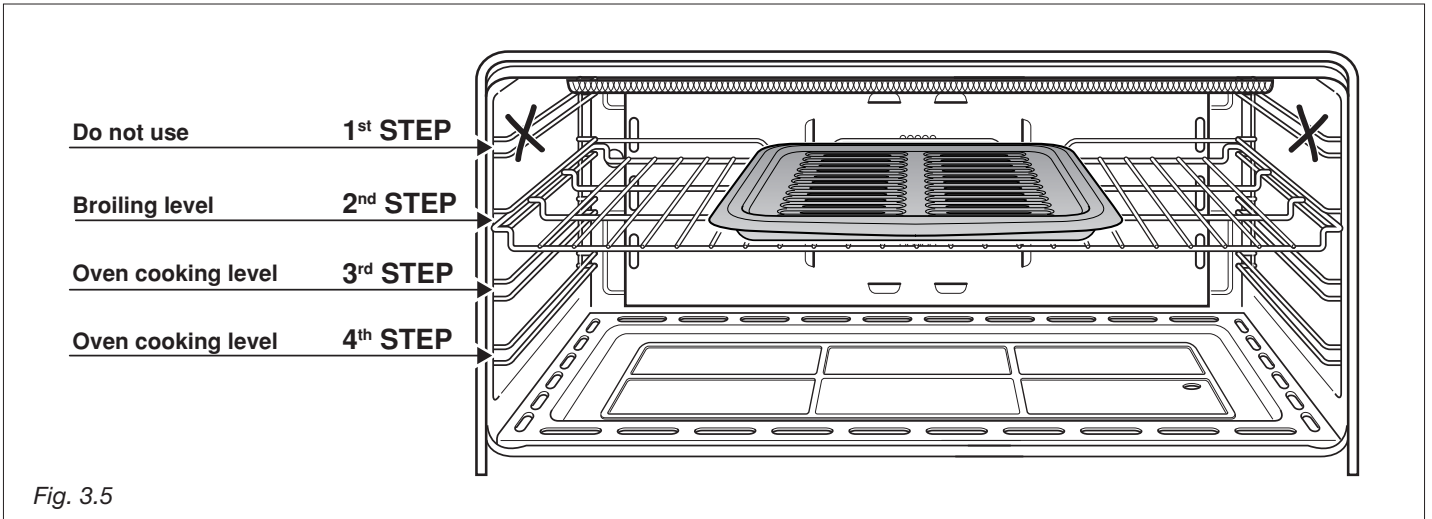

Fig. 3.5

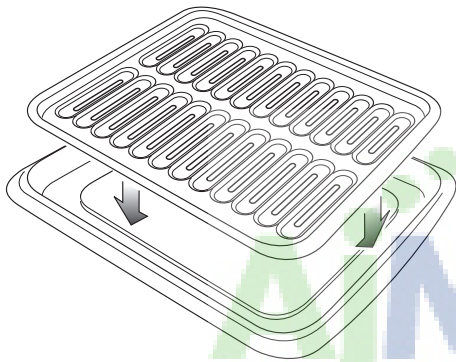

Fig. 3.6

BROILING

Very important: the broil burner must always be used with the oven door closed.

- Position the shelf on the second level from the top (fig. 3.5).
- Turn **on** the broil burner, as explained in the preceding paragraphs and let the broil burner preheat for about 5 minutes with the door closed.
- Place the food to be cooked above the broiling pan.
- Introduce the broiling pan in the oven (fig. 3.8). The broiling pan should be placed above the shelf and it should be centered with the broil burner (fig. 3.5).

Do not broil without using the broiling pan.

Important: Use always suitable protective gloves when inserting/removing the broiling pan, shelves, pans or other cooking utensils from the oven.

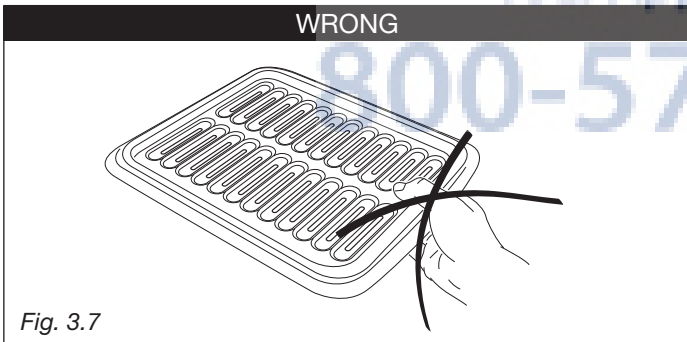

Fig. 3.7

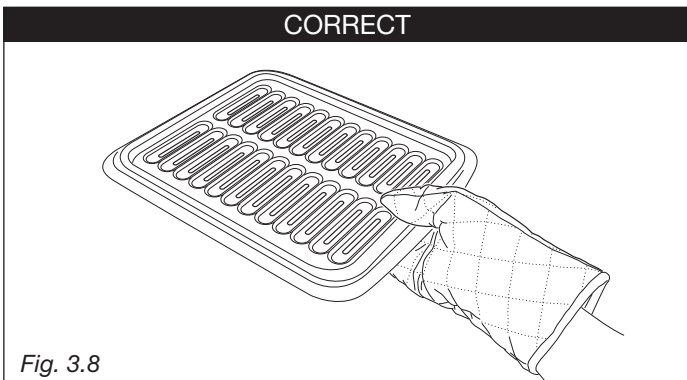

Fig. 3.8

MINUTE COUNTER (fig. 4.1)

The minute counter is a timed acoustic warning device which can be set for a maximum of 60 minutes.

The knob (Fig. 4.1) must be rotated clockwise as far as the 60 minute position and then set to the required time by rotating it anticlockwise.

IMPORTANT WARNING: This is only a mechanical timer.
Remember to turn off the oven/broil manually.

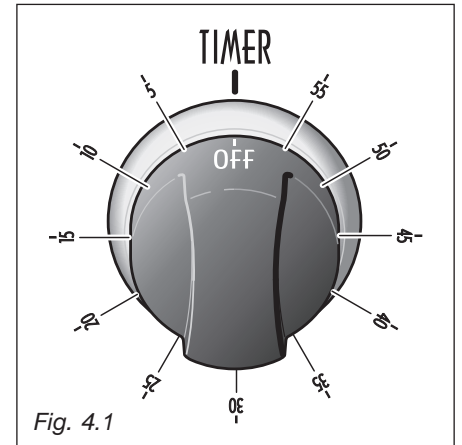

AjMadison
Your Appliance Authority™
800-570-3355

⚠ WARNING**Electrical Shock Hazard**

Plug into a grounded 3-prong outlet.

Do not remove ground prong.

Do not use an adapter.

Failure to follow these instructions can result in death, fire, or electrical shock.

GENERAL RECOMANDATION

- ✓ **Important:** Before any operation of cleaning and maintenance disconnect the appliance from the electrical supply.
- ✓ It is advisable to clean when the appliance is cold and especially for cleaning the enamelled parts.
- ✓ Avoid leaving alkaline or acidic substances (lemon juice, vinegar, etc.) on the surfaces.
- ✓ Avoid using cleaning products with a chlorine or acidic base.
The oven must always be cleaned after every use, using suitable products and keeping in mind that its operation for 30 minutes on the highest temperature eliminates most grime reducing it to ashes.

WARNING

When correctly installed, your product meets all safety requirements laid down for this type of product category. However special care should be taken around the rear or the underneath of the appliance as these areas are not designed or intended to be touched and may contain sharp or rough edges, that may cause injury.

ENAMELLED PARTS

- ✓ All the enamelled parts must be cleaned with a sponge and soapy water or other non-abrasive products.
- ✓ Dry preferably with a microfibre or soft cloth.
- ✓ Acidic substances like lemon juice, tomato sauce, vinegar etc. can damage the enamel if left too long.

PAINTED PARTS AND SILK-SCREEN PRINTED SURFACES

- ✓ Clean using an appropriate product. Always dry thoroughly.

IMPORTANT: these parts must be cleaned very carefully to avoid scratching and abrasion. You are advised to use a soft cloth and neutral soap.

STAINLESS STEEL ELEMENTS

- ✓ Stainless steel parts must be rinsed with water and dried with a soft and clean cloth.
- ✓ For difficult dirt, use a specific non-abrasive product available commercially or a little hot vinegar.
- ✓ **Note:** regular use could cause discolouring around the burners, because of the high flame temperature.

INSIDE OF OVEN

The oven should always be cleaned after use when it has cooled down. The cavity should be cleaned using a mild detergent solution and warm water. Suitable proprietary chemical cleaners may be used after first consulting with the manufacturers recommendations and testing a small sample of the oven cavity. Abrasive cleaning agents or scouring pads/cloths should not be used on the cavity surface.

NOTE: The manufacturers of this appliance will accept no responsibility for damage caused by chemical or abrasive cleaning.

Let the oven cool down and pay special attention no to touch the hot heating elements inside the oven cavity.

3-prong polarized
ground-type outlet

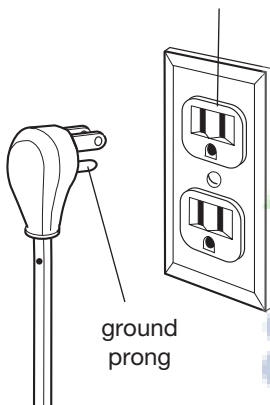

ground
prong

**WARNING
VERY IMPORTANT**

Before any operation of maintenance disconnect the appliance from the electrical mains supply.

Do not use steam jet cleaners because the humidity could infiltrate into the appliance making it dangerous.

BURNERS AND GRIDS

- ✓ These parts can be removed and cleaned with appropriate products.
- ✓ After cleaning, the burners and their flame distributors must be well dried and correctly replaced.
- ✓ It is very important to check that the burner flame distributor and the cap has been correctly positioned - failure to do so can cause serious problems.
- ✓ Check that the probe next to each burner is always clean to ensure correct operation of the safety valves.
- ✓ In appliances with electric ignition keep the electrode clean so that the sparks always strike.
- ✓ **Note: To avoid damage to the electric ignition do not use it when the burners are not in place.**

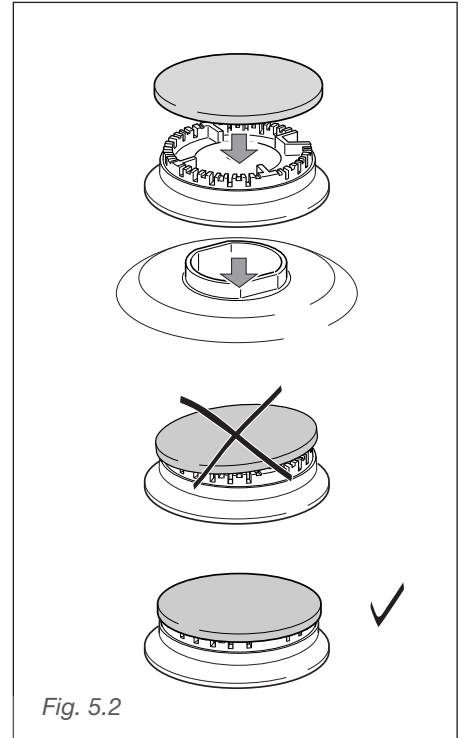
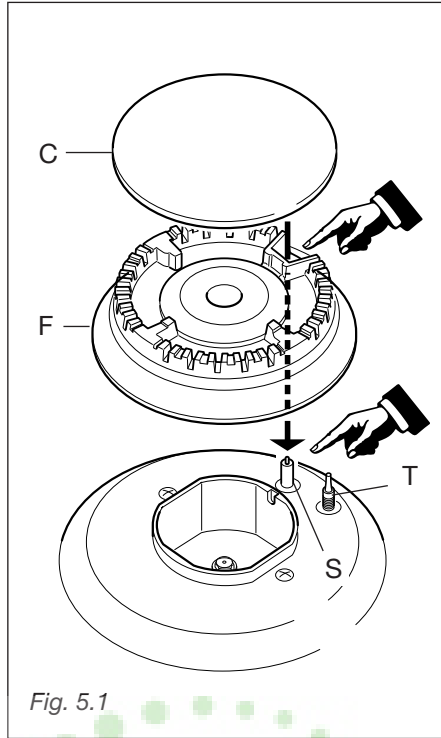

CORRECT REPLACEMENT OF THE SEMI-RAPID BURNERS

It is very important to check that the burner flame spreader "F" and the cap "C" have been correctly positioned (see figs. 5.1 and 5.2). Failure to do so can cause serious problems.

In appliances with electric ignition, check that the electrode "S" (figs. 5.1 - 5.3) is always clean to ensure trouble-free sparking.

Check that the probe "T" (figs. 5.1 - 5.3) next to each burner is always clean to ensure correct operation of the safety valves.

Both the probe and ignition plug must be very carefully cleaned.

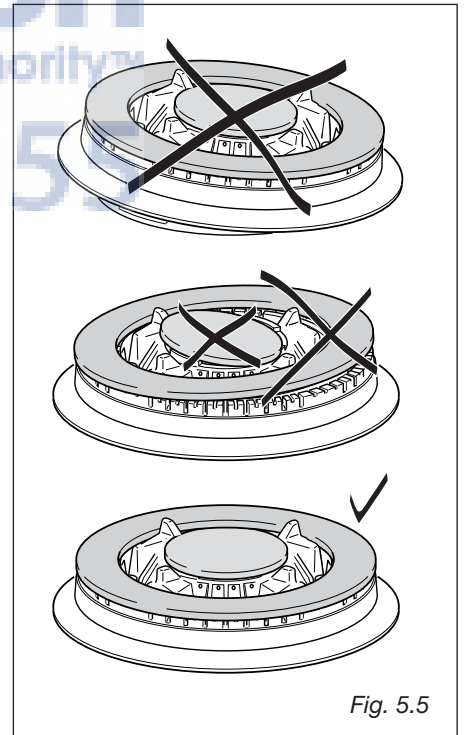
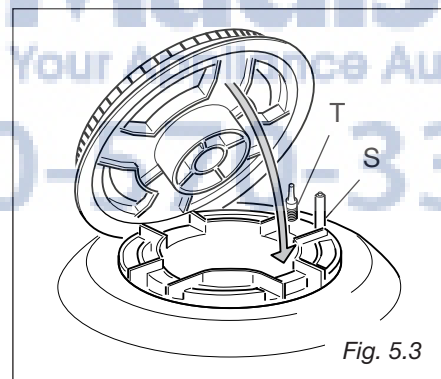

CORRECT POSITION OF TRIPLE RING BURNERS

The triple ring burner must be correctly positioned (see fig. 5.3); the burner rib must be fitted in their housing as shown by the arrow.

The burner correctly positioned must not rotate (fig. 5.4).

Then position the cap A and the ring B (figs. 5.4 - 5.5).

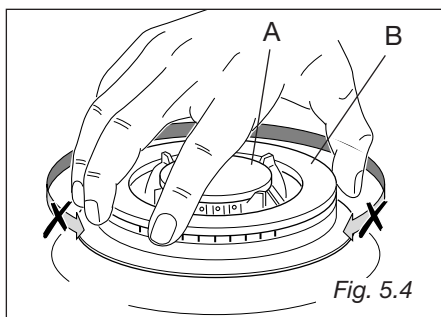

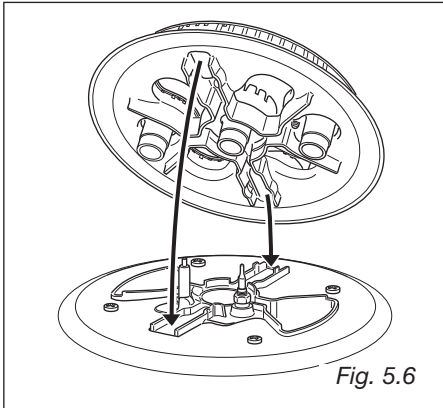

CORRECT POSITION OF DUAL BURNER

The DUAL burner must be correctly positioned (see fig. 5.6); the burner rib must be fitted as shown by the arrows.

Position the central small cap in its housing as shown by the arrows (fig. 5.7).

Position the big cap in its housing as shown by the arrows (fig. 5.8).

IMPORTANT: NEVER unscrew the burner screws (fig. 5.9).

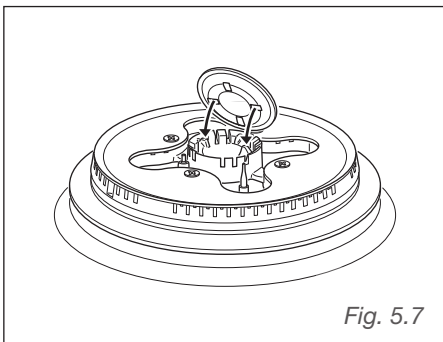

GAS VALVES

In the event of operating faults in the gas valves, call the Service Department.

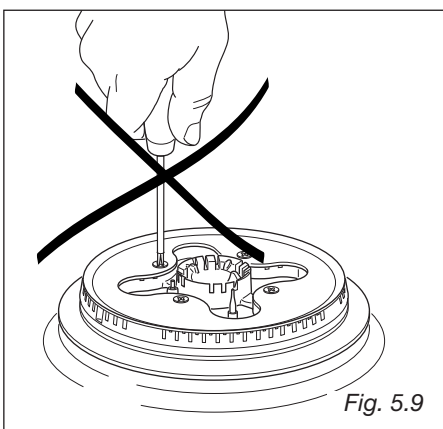
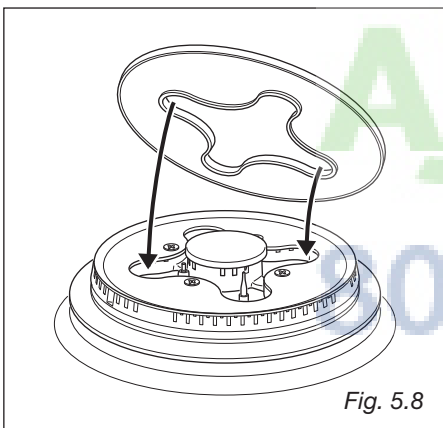

OVEN ACCESSORIES INSTALLATION AND REMOVAL

- Hang up the wire racks "G" on the oven walls (fig. 5.10).
- Slide in, on the guides, the shelves (fig. 5.11). Do not use the first step from the top. The rack must be fitted so that the safety catch, which stops it sliding out, faces the inside of the oven.
- Position the broiling pan above the oven shelf (see page 18).
- To dismantle, operate in reverse order.

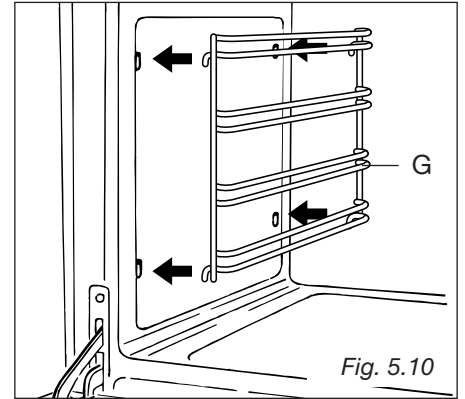

Fig. 5.10

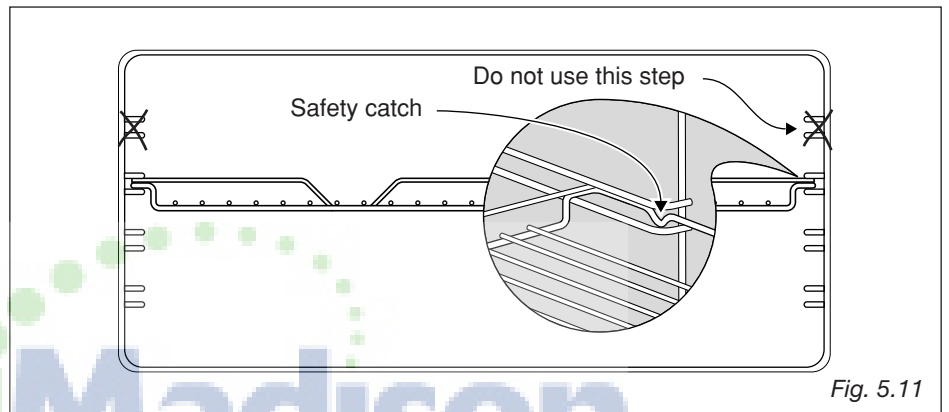

Fig. 5.11

OVEN DOOR

The internal glass panel can be easily removed for cleaning by unscrewing the retaining screws (Fig. 5.12)

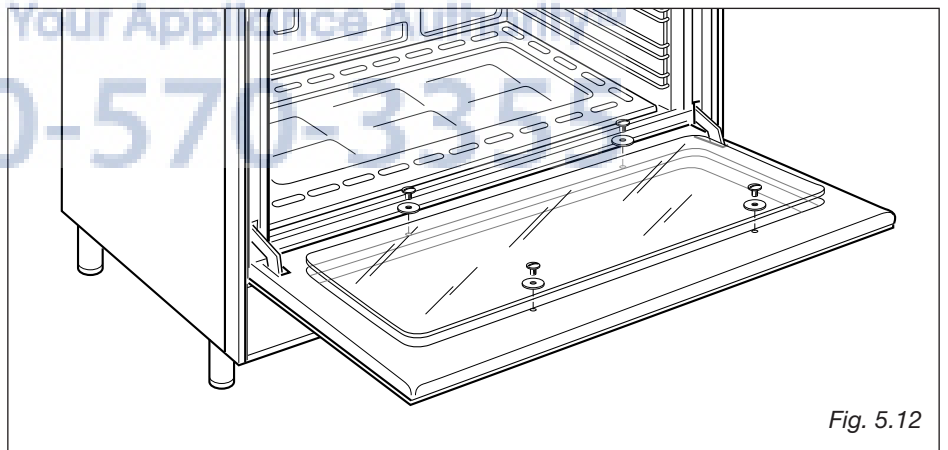

Fig. 5.12

STORAGE COMPARTMENT

The storage compartment is accessible through the pivoting panel (fig. 5.13).

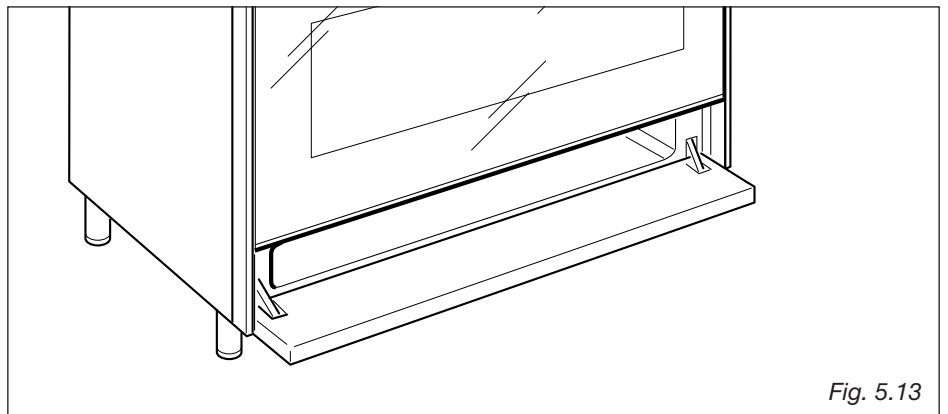

Fig. 5.13



WARNING!!

Do not store flammable material in the oven or in the storage compartment.

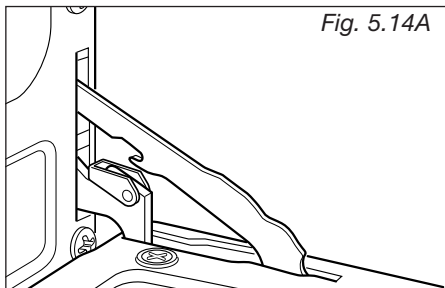

Fig. 5.14A

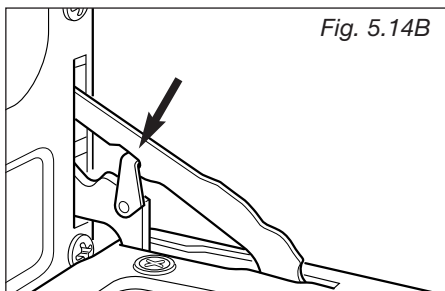

Fig. 5.14B

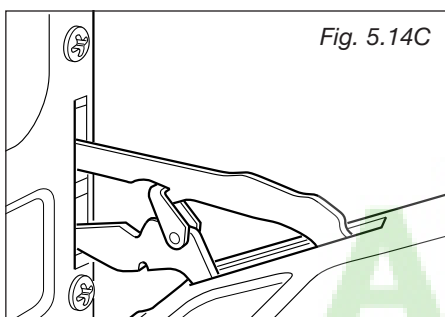

Fig. 5.14C

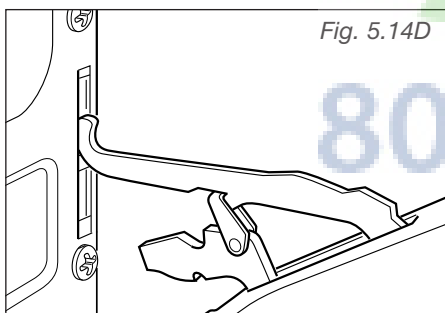

Fig. 5.14D

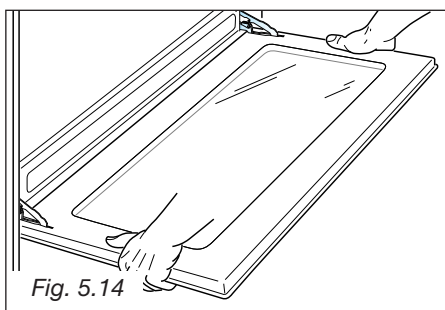

Fig. 5.14

REMOVING THE OVEN DOOR

The oven door can easily be removed as follows:

- Open the door to the full extent (fig. 5.14A).
- Attach the retaining rings to the hooks on the left and right hinges (fig. 5.14B).
- Hold the door as shown in fig. 5.14.
- Gently close the door and withdraw the lower hinge pins from their location (fig. 5.14C).
- Withdraw the upper hinge pins from their location (fig. 5.14D).
- Rest the door on a soft surface.
- To replace the door, repeat the above steps in reverse order.



Aj Madison
 Your Appliance Authority™
 800-570-3355

REPLACING THE OVEN LIGHT

Before any maintenance is started involving electrical parts of the appliance, it must be disconnected from the power supply.

- ✓ Let the oven cavity and the broil burner cool down;
- ✓ Switch off the electrical supply;
- ✓ Remove the protective cover;
- ✓ Unscrew and replace the bulb with a new one suitable for high temperatures (300°C-570°F) having the following specifications: 120V 60 Hz, 15W, E14;
- ✓ Refit the protective cover.

NOTE: Oven bulb replacement is not covered by your guarantee.

DO'S AND DO NOT'S

- Do always use the oven with the door closed.
- Do always broil with the door closed.
- Do read the user instructions carefully before using the range for first time.
- Do allow the oven to heat for about two hours, before using for the first time, in order to expel any smell from the new oven insulation, without the introduction of food.
- Do clean your oven regularly.
- Do remove spills as soon as they occur.
- Do always use oven gloves when removing food shelves and trays from the oven.
- Do not allow children near the range when in use.
- Do not allow fat or oils to build up in the oven base, or oven accessories.
- Do not place cooking utensils or plates directly onto the oven base.
- Do not place hot enamel parts in water. Leave them to cool first.
- Do not allow vinegar, coffee, milk, saltwater, lemon or tomato juice to remain in contact with enamel parts (i.e. inside the oven).
- Do not use abrasive cleaners or powders that will scratch the surface of the stainless steel and the enamel.
- Do not attempt to repair the internal workings of your range.
- Do remove the protective film before the first use.
- Fire risk! Do not store flammable material in the oven and in the storage compartment.
- Do not use the oven with the oven door open.
- Do not use the oven to warm or heat a room.



FOR YOUR SAFETY

Under no circumstances should any external covers be removed for servicing or maintenance except by suitably qualified personnel





The manufacturer cannot be held responsible for possible inaccuracies due to printing or transcription errors in the present booklet.

The manufacturer reserves the right to make all modifications to its products deemed necessary for manufacture or commercial reasons at any moment and without prior notice, without jeopardising the essential functional and safety characteristics of the appliances.

