

SINGLE OVEN DUAL FUEL RANGE

for residential use only



Models: **VEFSGE 365 ..**

- **INSTALLATION INSTRUCTIONS**
IMPORTANT - PLEASE READ AND FOLLOW



IMPORTANT - PLEASE READ AND FOLLOW

- ✓ Before beginning, please read these instructions completely and carefully.
- ✓ Do not remove permanently affixed labels, warnings, or plates from the product. This may void the warranty.
- ✓ Please observe all local and national codes and ordinances.
- ✓ Please ensure that this product is properly grounded.
- ✓ **The installer should leave these instructions with the consumer who should retain for local inspector's use and for future reference.**

Installation must conform with local codes or in the absence of codes, the National Fuel Gas Code ANSI Z223.1 - latest edition. Electrical installation must be in accordance with the National Electrical Code, ANSI/NFPA 70 - latest edition and/or local codes. IN CANADA: Installation must be in accordance with the current CAN/CGA-B149.1 National Gas Installation Code or CAN/CGA-B149.2, Propane Installation Code and/or local codes. Electrical installation must be in accordance with the current CSA C22.1 Canadian Electrical Codes Part 1 and/or local codes.

INSTALLATION IN MANUFACTURED (MOBILE) HOME: The installation must conform with the Manufactured Home Construction and Safety Standard, Title 24 CFR, Part 3280 [formerly the Federal Standard for Mobile Home Construction and Safety, Title 24, HUD (Part 280)] or, when such standard is not applicable, the Standard for Manufactured Home Installations, ANSI/NCSBCS A225.1, or with local codes where applicable.

INSTALLATION IN RECREATIONAL PARK TRAILERS: The installation must conform with state or other codes or, in the absence of such codes, with the Standard for Recreational Park Trailers, ANSI A119.5.

Installation of any gas-fired equipment should be made by a licensed plumber. A manual shut-off valve must be installed in an accessible location in the gas line external to the appliance for the purpose of turning on or shutting off gas to the appliance (In Massachusetts such shutoff devices should be approved by the Board of State Examiners of Plumbers & Gas Fitters).

If an external electrical source is utilized, the appliance, when installed, must be electrically grounded in accordance with local codes or, in the absence of local codes, with the national Electrical Code, ANSI/NFPA 70.

**This range is supplied with a protective film on steel and aluminium parts.
This film must be removed before installing/using the appliance.**

FOR INSTALLER ONLY

THIS RANGE IS FOR RESIDENTIAL USE ONLY



WARNING

- ALL RANGES CAN TIP
- INJURY TO PERSON COULD RESULT
- INSTALL ANTI-TIP DEVICE PACKED WITH RANGE
- SEE INSTALLATION INSTRUCTIONS

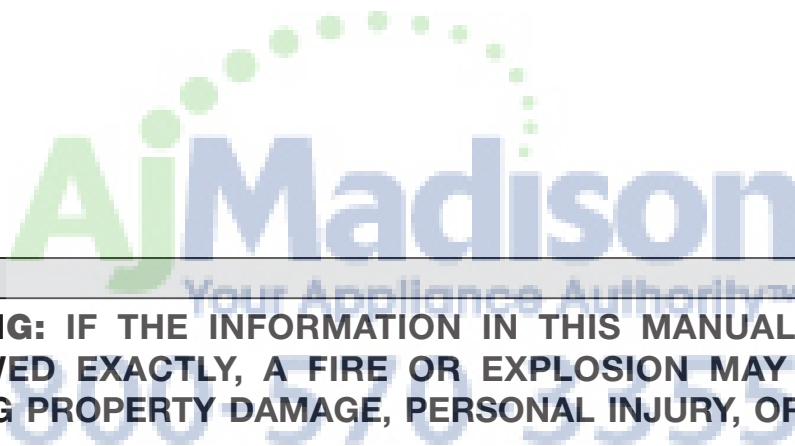

WARNING: IF THE INFORMATION IN THIS MANUAL IS NOT FOLLOWED EXACTLY, A FIRE OR EXPLOSION MAY RESULT CAUSING PROPERTY DAMAGE, PERSONAL INJURY, OR DEATH.

- ✓ Do not store or use gasoline or other flammable vapors and liquids in the vicinity of this or any other appliance.
- ✓ **WHAT TO DO IF YOU SMELL GAS:**
 - Do not try to light any appliance.
 - Do not touch any electrical switch; do not use any phone in your building.
 - Immediately call your gas supplier from a neighbor's phone. Follow the gas supplier's instructions.
 - If you cannot reach your gas supplier, call the fire department.
- ✓ Installation and service must be performed by a qualified installer, service agency, or the gas supplier.

DATA PLATE



This appliance is designed and manufactured solely for the cooking of domestic (household) food and is not suitable for any non-domestic application and therefore should not be used in a commercial environment.

The appliance guarantee will be void if the appliance is used within a non-domestic environment i.e. a semi-commercial, commercial or communal environment.

INSTALLATION INSTRUCTIONS



WARNING!

THIS APPLIANCE HAS TO BE INSTALLED BY A QUALIFIED INSTALLER.

Improper installation, adjustment, alteration, services, or maintenance can cause injury or property damage. Consult a qualified installer, service agent, or the gas supplier.

IMPORTANT: The use of suitable protective clothing/gloves is recommended when handling, installing of this appliance.

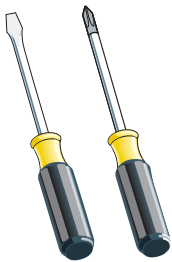
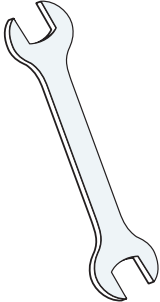
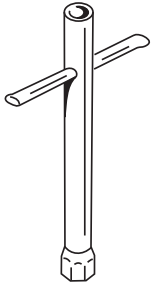
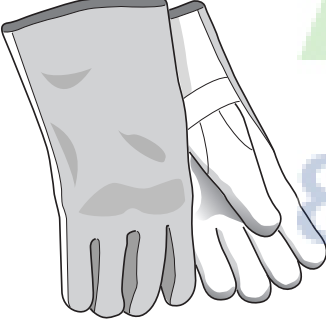
TOOLS NEEDED FOR INSTALLATION (NOT SUPPLIED WITH THE APPLIANCE)

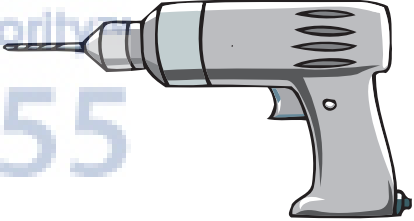
 <p>Screwdriver</p>	 <p>2 - Wrench</p>	 <p>T-handle wrench</p>	 <p>Pencil</p>	 <p>Tape measure</p>
 <p>Suitable protective gloves</p>	 <p>Hammer</p>	 <p>Adjustable wrench</p>	 <p>Adjustable pliers</p>	 <p>Drill</p>

GENERAL INFORMATION

1. Installation must conform with local codes or, in the absence of local codes, with the **National Fuel Gas Code, ANSI Z223.1-Latest Edition.**
2. Installation in manufactured (mobile) home: installation must conform with the **Manufactured Home Construction and Safety Standard, Title 24 CFR, Part 3280 [formerly the Federal Standard for Mobile Home Construction and Safety, Title 24, HUD (Part 280)]** or, when such standard is not applicable, the **Standard for Manufactured Home Installations, ANSI/NCSBCS A225.1,** or with local codes where applicable.
3. Installation in Recreational Park Trailers: installation must conform with state or other codes or, in the absence of such codes, with the **Standard for Recreational Park Trailers, ANSI A119.5.**



WARNING!!

This appliance shall not be used for space heating. This information is based on safety considerations.

4. All openings in the wall behind the appliance and in the floor under the appliance shall be sealed.
5. Keep appliance area clear and free from combustible materials, gasoline, and other flammable vapors.
6. Do not obstruct the flow of combustion and ventilation air.
7. Disconnect the electrical supply to the appliance before servicing.
8. When removing appliance for cleaning and/or service:
 - A. Shut off gas at main supply.
 - B. Disconnect AC power supply.
 - C. Disconnect gas line to the inlet pipe.
 - D. Carefully remove the range by pulling outward.**CAUTION:** Range is heavy; use care in handling.

10. Electrical Requirement

Electrical installation should comply with national and local codes.

11. Air Supply and Ventilation

The installer must refer to local/national codes.

12. Gas Manifold Pressure

Natural gas - 4.0" W.C.P.
LP/Propane - 11.0" W.C.P.

13. The misuse of oven door (e.g. stepping, sitting, or leaning on them) can result in potential hazards and/or injuries.
14. When installing or removing the range for service, a rolling lift jack should be used. Do not push against any of the edges of the range in an attempt to slide it into or out of the installation. Pushing or pulling a range (rather than using a lift jack) also increases the possibility of bending the leg spindles or the internal coupling connectors.



WARNING!!

ELECTRICAL GROUNDING INSTRUCTIONS

The range must be electrically grounded in accordance with local codes or, in the absence of local codes, with the **National Electrical Code, ANSI/NFPA No. 70-latest edition.** Installation should be made by a licensed electrician.

FOR PERSONAL SAFETY, THIS APPLIANCE MUST BE PROPERLY GROUNDED.

If an external electrical source is utilized, the installation must be electrically grounded in accordance with local codes or, in the absence of local codes, with the national Electrical Code, ANSI/NFPA 70.

REPLACEMENT PARTS

Only authorized replacement parts may be used in performing service on the range. Replacement parts are available from factory authorized parts distributors. Contact the nearest parts distributor in your area.

AjMadison
Your Appliance Authority™
800-570-3355

PROXIMITY TO SIDE CABINETS

1. This range may be installed directly adjacent to existing 36" (914 mm) high base cabinets.

Range dimensions:

- width: 35" 7/8 (911 mm)
- depth: 23" 31/32 (609 mm)
- height (without backguard / island trim): MIN 35" 7/16 (900 mm) MAX 37" 13/32 (950 mm)
- backguard (height): 8" (203 mm)
- island trim (height): 3" (76 mm)

Gas line opening:

Wall - 7" 15/32 (190 mm) from the floor; 17" 15/16 (455.5 mm) from the rear left side to centre of the range.

Grounded outlet: Grounded outlet should be located 17" 15/16 (455.5 mm) from the right side to centre of range and from 6" 11/16 (170 mm) to 8" 21/32 (220 mm) [depending on feet regulation] from the floor.

2. The range CANNOT be installed directly adjacent to side-walls, tall cabinets, tall appliances, or other side vertical surfaces above 36" (914 mm) high.

There must be a minimum of 11" 13/16 (300 mm) side clearance from the range to such combustible surfaces TO THE LEFT or TO THE RIGHT above the 36" (914 mm) high countertop.

IMPORTANT: One side (left or right) above the 36" (914 mm) high countertop must always be kept clear.

Installation with island trim: There must be a minimum of 12" (305 mm) clearance from the back of the island trim to such combustible surface on the back of the range above the 36" (914 mm) high countertop.

3. The maximum upper cabinet depth recommended is 13" (330 mm). Wall cabinet above the range must be a minimum of 30" (762 mm) above the countertop for a width of minimum 35" 7/8 (911 mm); it has to be centred with the range. Side wall cabinets above the range must be a minimum of 18" (457 mm) above the countertop.

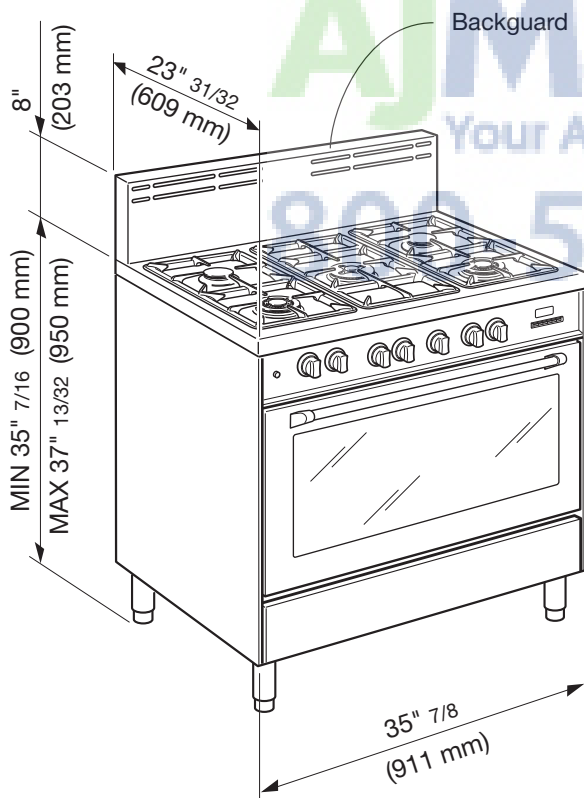

Fig. 1.1a

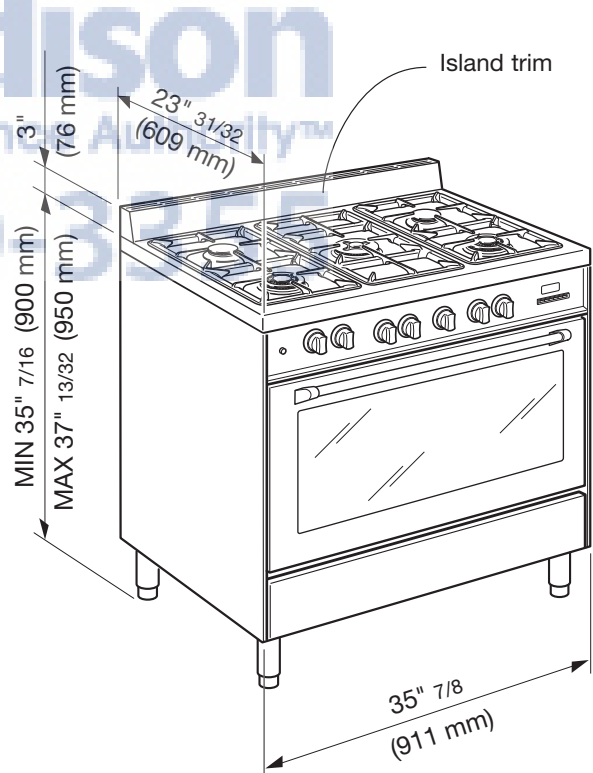

Fig. 1.1b

GAS AND ELECTRIC CONNECTION

Rif.	inch	mm
A	7" 15/32	190
B	17" 15/16	455.5
C	6" 11/16 ÷ 8" 21/32 (*)	170 ÷ 220 (*)
D	17" 15/16	455.5

* : Depending on feet regulation

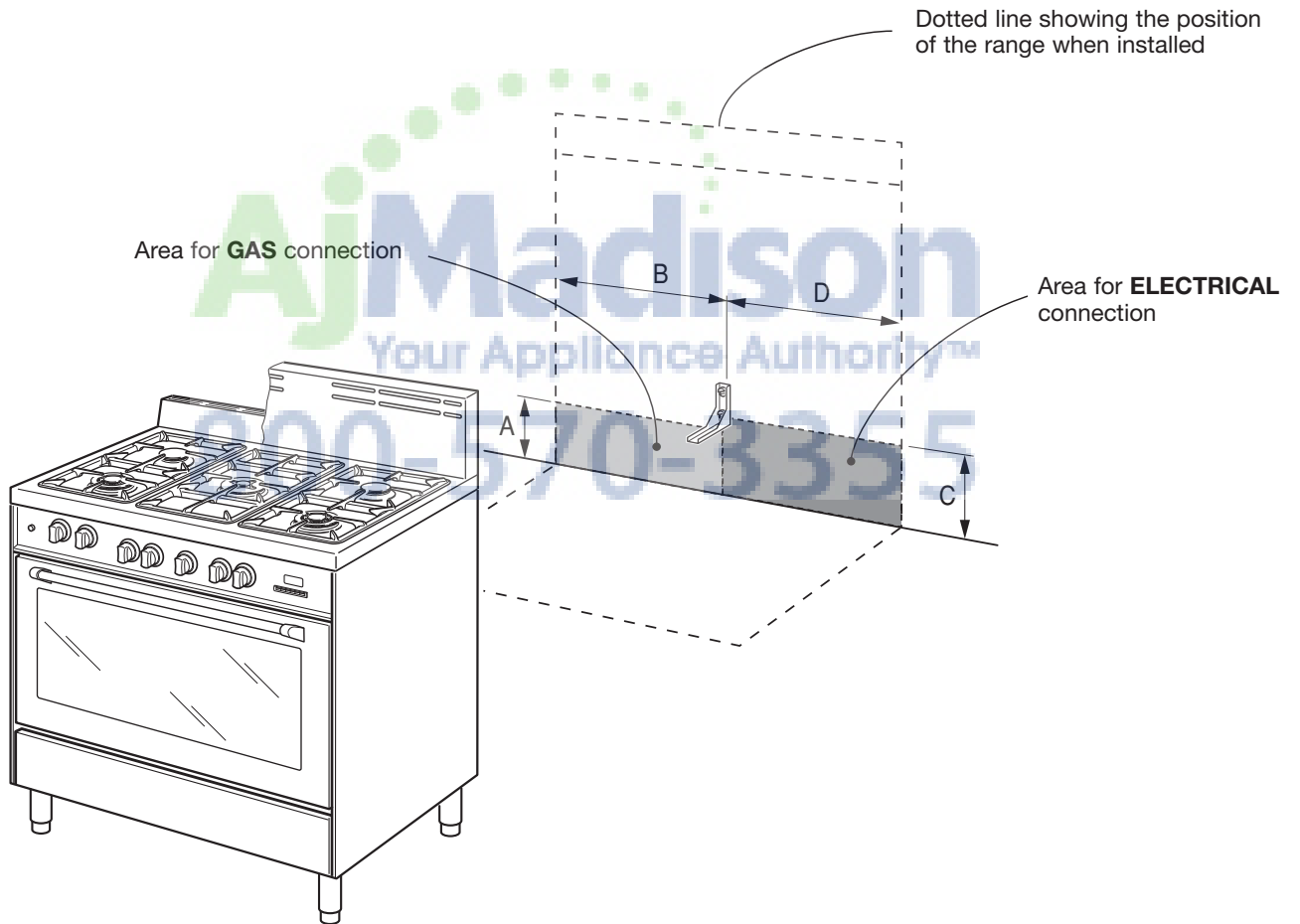
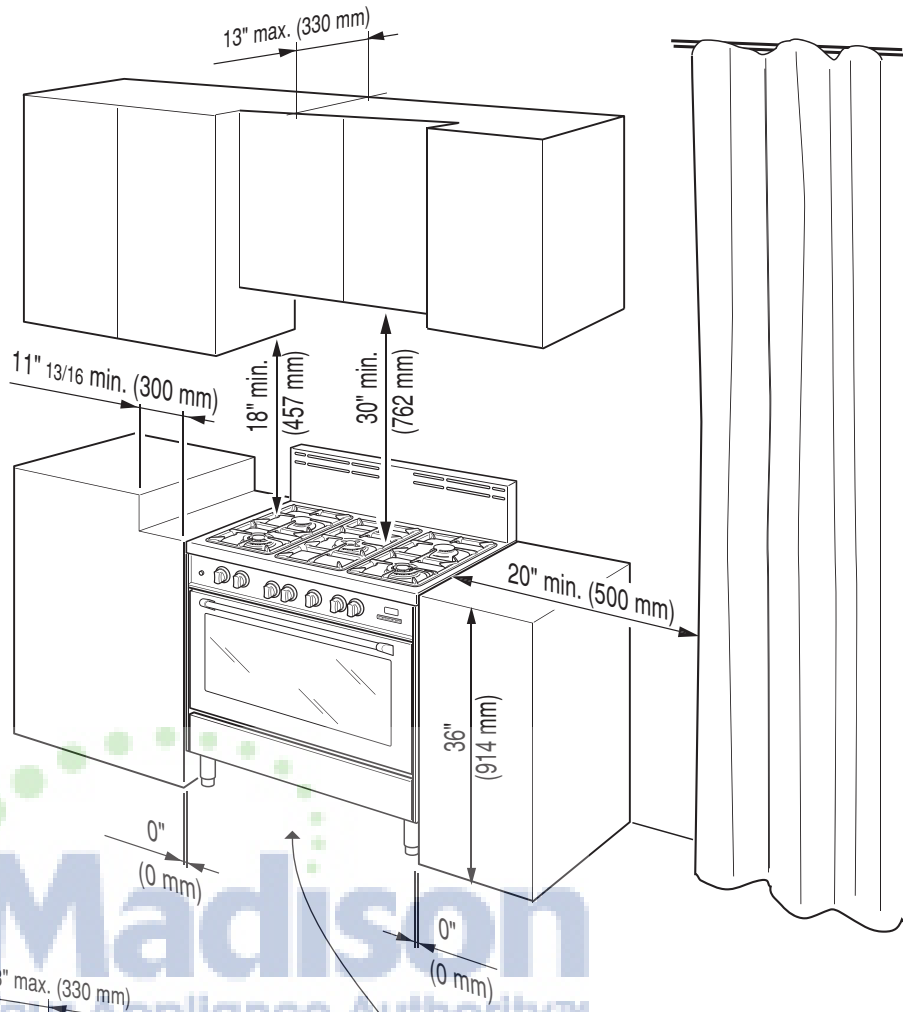

Fig. 1.2

PROXIMITY TO SIDE CABINETS
RANGE WITH BACKGUARD

Fig. 1.3a



AjMadison
 Your Appliance Authority™
 800-570-3355

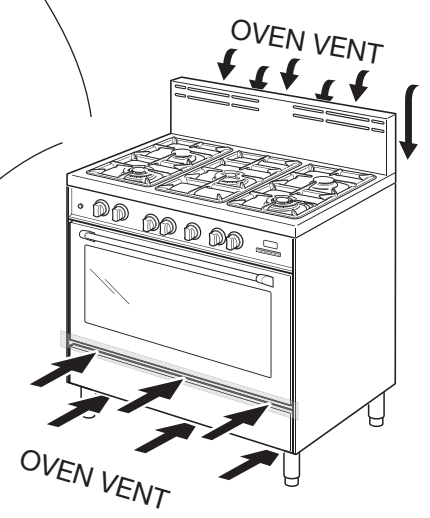
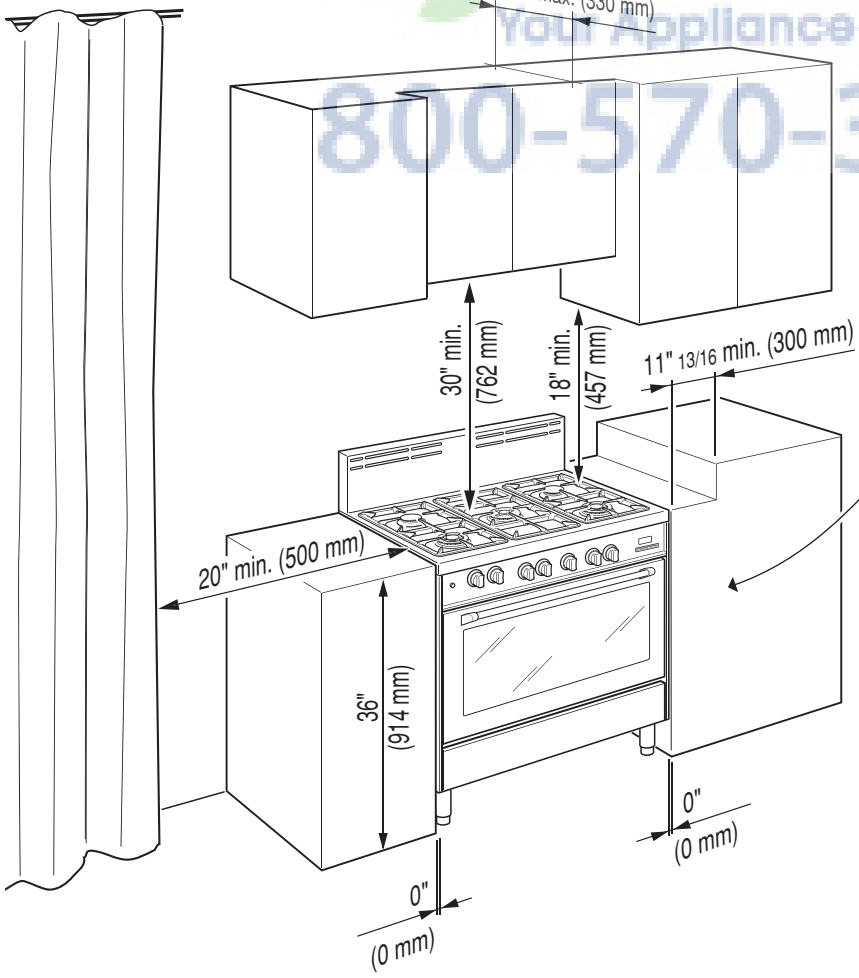

Fig. 1.3b

PROXIMITY TO SIDE CABINETS RANGE WITH ISLAND TRIM

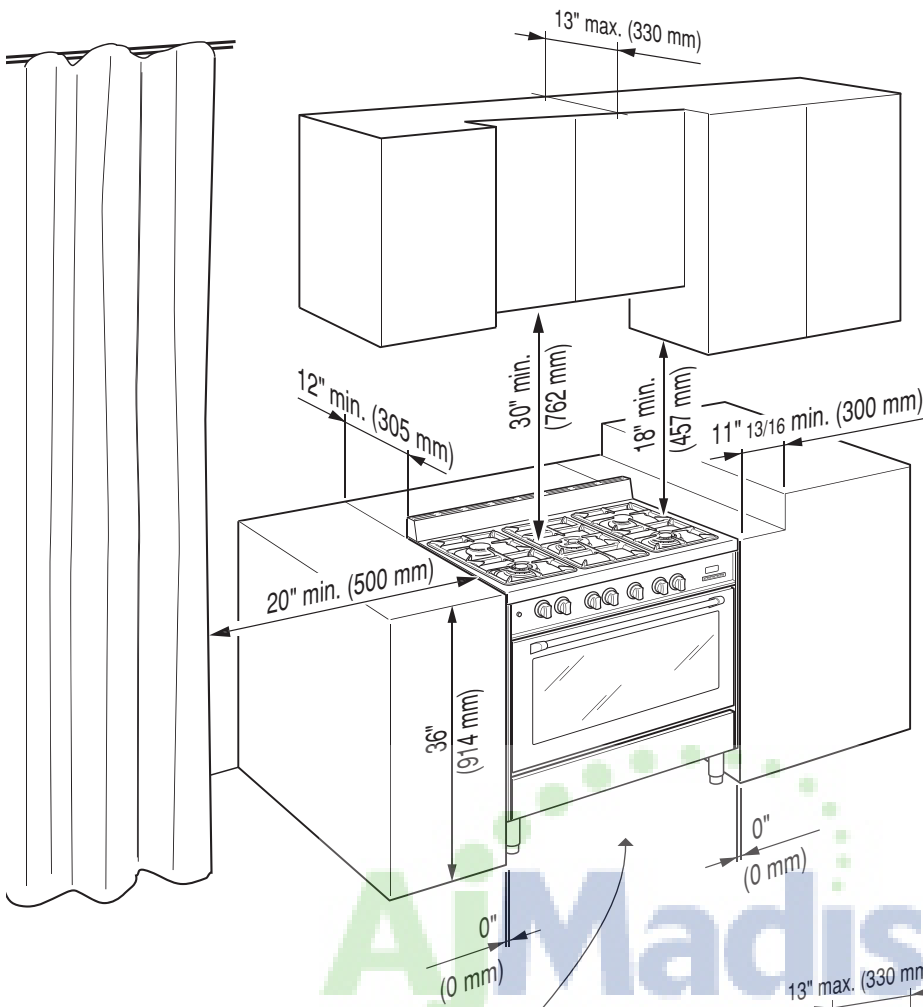

Fig. 1.3c

Appliance Authority™
Your Appliance Authority™
800-570-3355

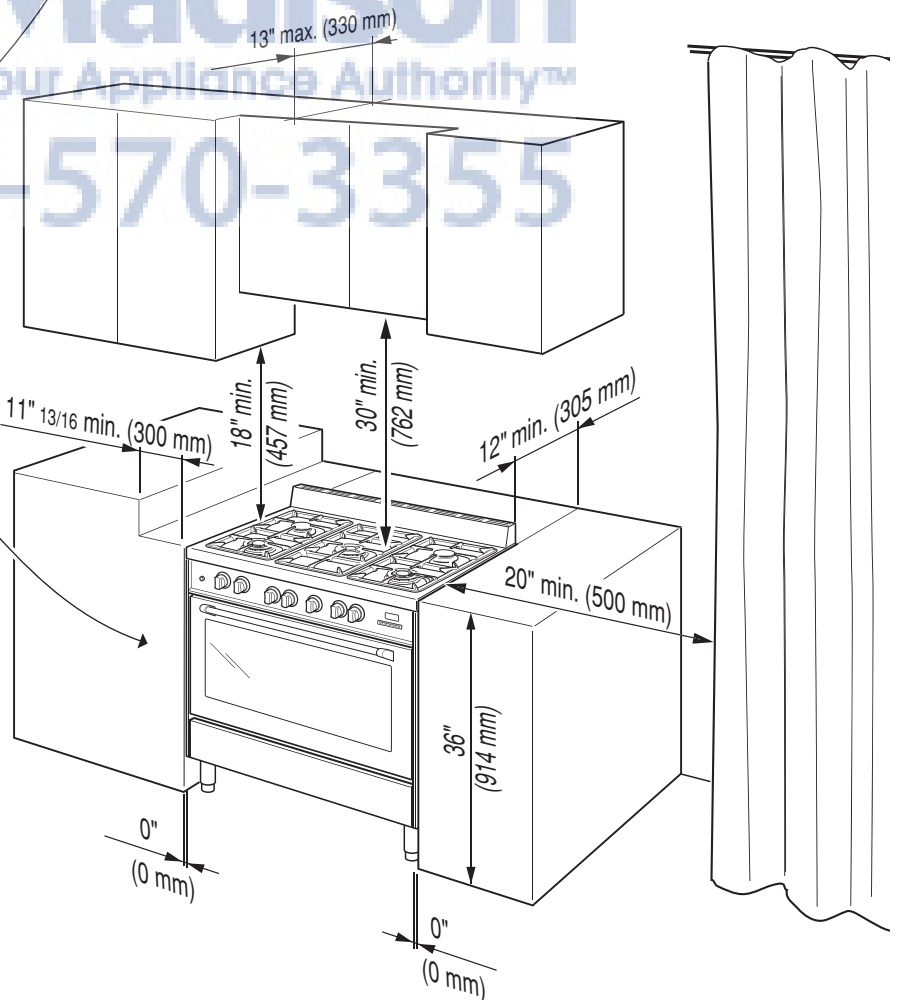
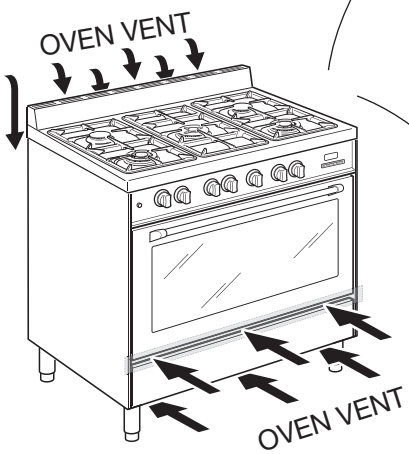
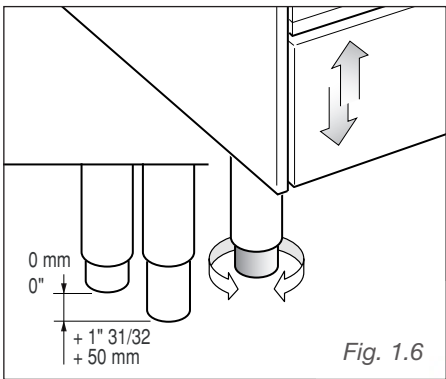
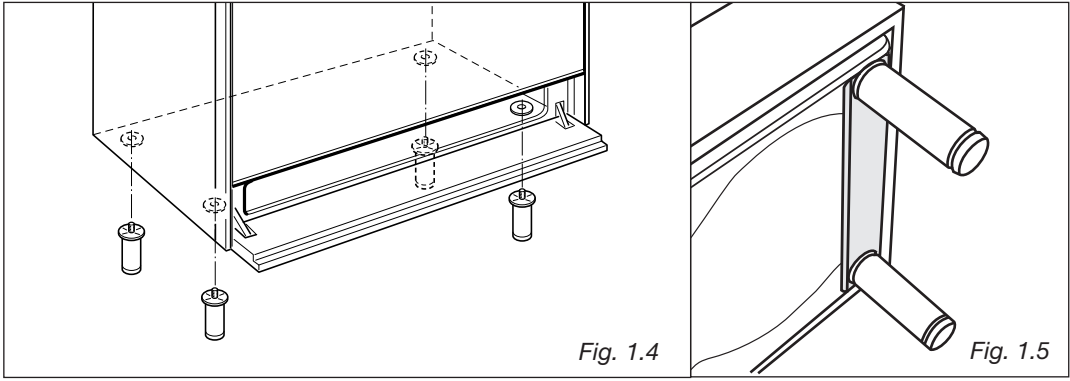

Fig. 1.3d



FITTING THE ADJUSTABLE FEET

The adjustable feet must be fitted to the base of the cooker before use. Rest the rear of the cooker on a piece of the polystyrene packaging exposing the base for the fitting of the feet.

ATTENTION: Most important! Pay special attention not to damage the range during this operation.

Fit the 4 legs by screwing them tight into the support base as shown in picture 1.5.

LEVELLING THE COOKER

The cooker may be levelled by screwing the lower ends of the feet IN or OUT (fig. 1.6). It is important to observe the directions of figure 1.6.

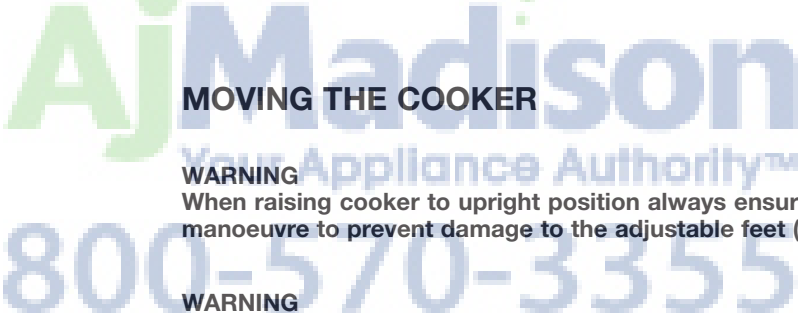

MOVING THE COOKER

WARNING
When raising cooker to upright position always ensure two people carry out this manoeuvre to prevent damage to the adjustable feet (fig. 1.7a).

WARNING
Be careful: do not lift the cooker by the door handle when raising to the upright position (fig. 1.7b).

WARNING
When moving cooker to its final position **DO NOT DRAG** (fig. 1.7c). Lift feet clear of floor (fig. 1.7a).

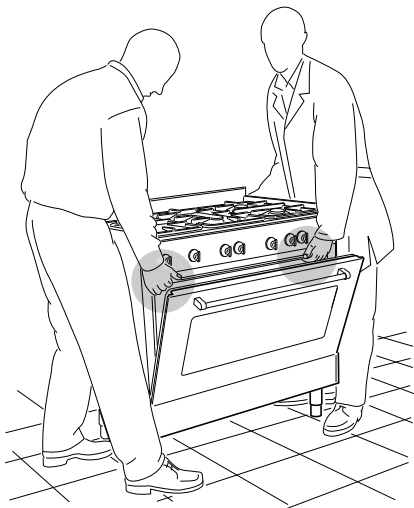

Fig. 1.7a

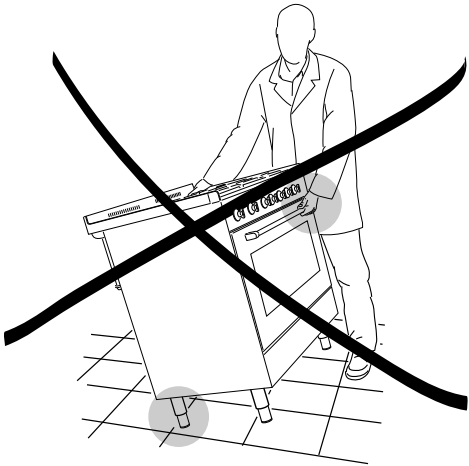

Fig. 1.7b

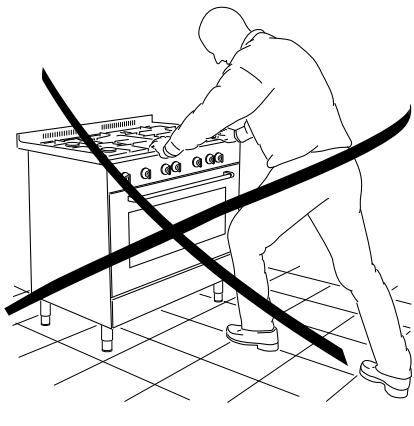

Fig. 1.7c

ASSEMBLING THE BACKGUARD OR THE ISLAND TRIM

It is mandatory to install the backguard or the island trim

- Assemble the backguard or the island trim as shown in figure 1.8 or 1.9 and fix it by screwing the 5 screws "A" (which are already fixed on the back of the cooktop).
- Do not remove the 3 spacers "B" already fitted on the back of the backguard or island trim.

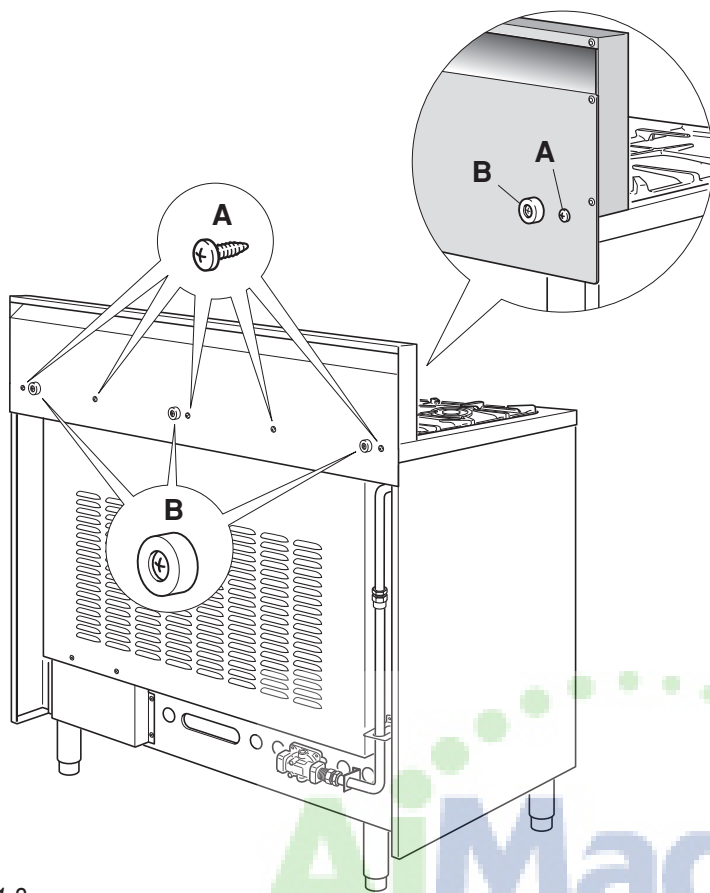
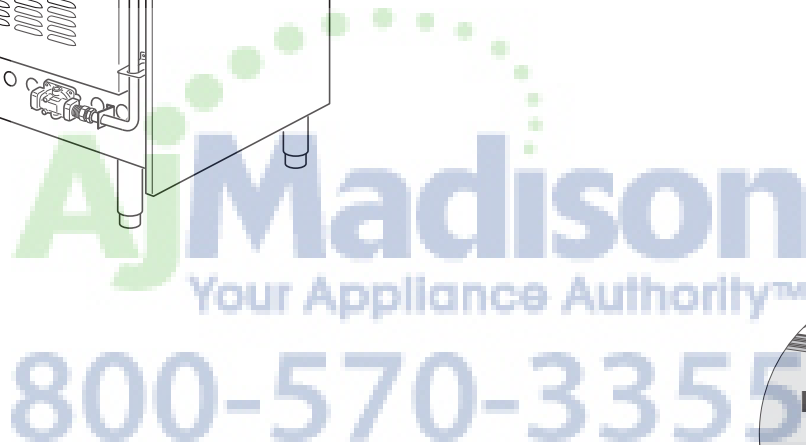

Fig. 1.8



 Your Appliance Authority™

 800-570-3355

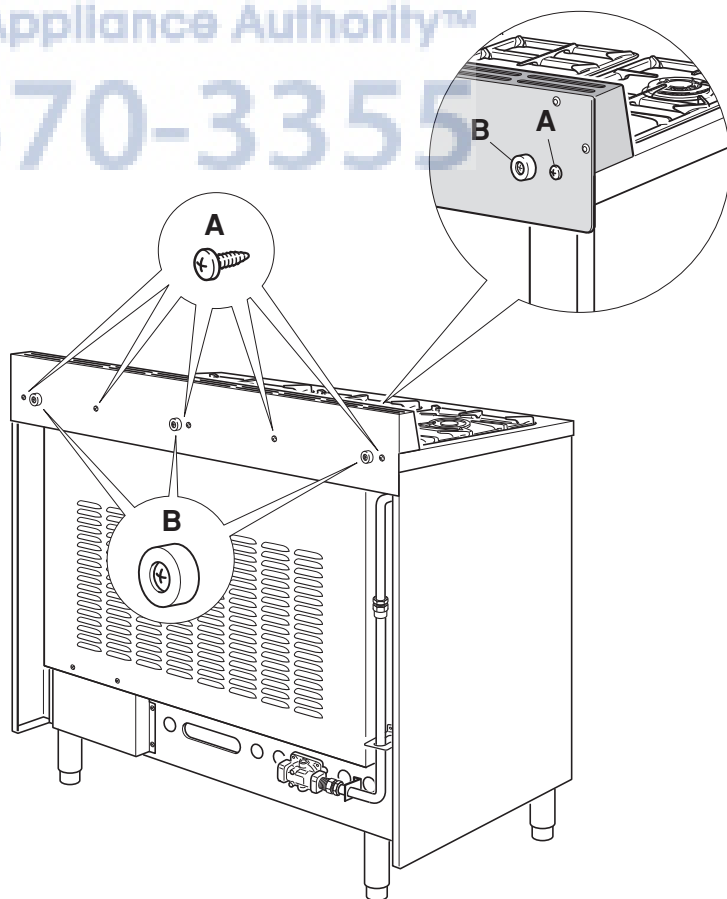

Fig. 1.9

YOU MUST USE STABILITY ANTI TIP BRACKET TO PREVENT UNIT FROM TIPPING.

ANTI-TIP STABILITY DEVICE INSTALLATION INSTRUCTIONS

1. The anti-tip bracket has to be attached as shown on figure below, it has to be fixed on the rear wall by no. 2 (two) suitable screws (supplied with the anti-tip kit).
2. After fixing the anti-tip bracket, slide range into place. Be sure the anti-tip bracket is fully inserted in the slot of the range back.

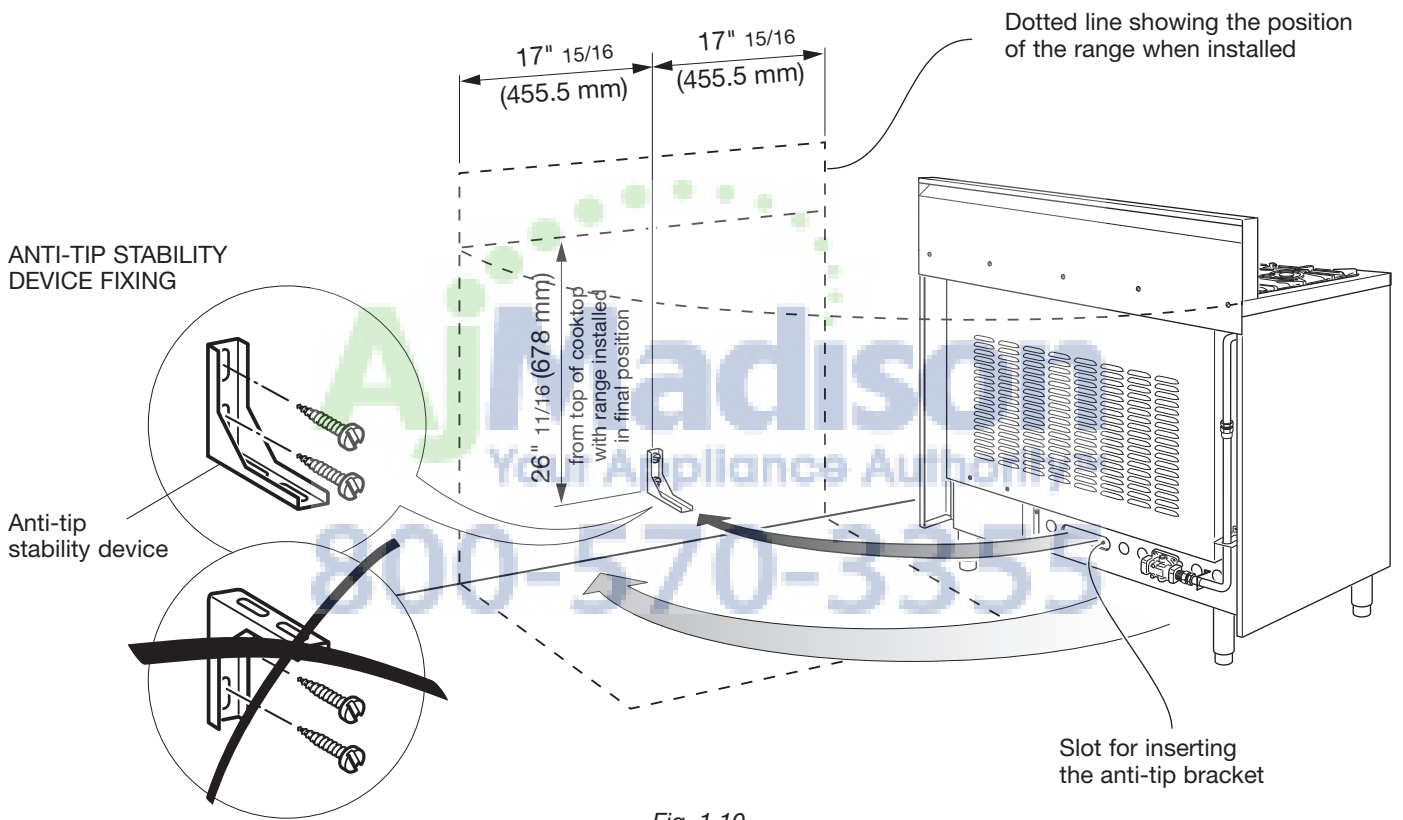

Fig. 1.10

All gas connections must be made according to national and local codes. This gas supply (service) line must be the same size or greater than the inlet line of the appliance. Sealant on all pipe joints must be resistant to the action of LP/Propane gas.

The range is equipped for the use with NATURAL gas. It is design-certified by CSA International for NATURAL and L.P. gases with appropriate conversion.

The model/serial rating plate, located on the inner side of the storage compartment pivoting panel, has information on the type of gas that can be used. If this information does not agree with the type of gas available, check with the local gas supplier. See page from 19 to 21 for L.P. gas conversion instructions.

1. Manual Shut-off Valve (fig. 2.1):

A manual shut-off valve must be installed in an accessible location in the gas line external to the appliance for the purpose of turning on or shutting off gas to the appliance (In Massachusetts such shutoff devices should be approved by the Board of State Examiners of Plumbers & Gas Fitters). This valve should be located in the same room as the range and should be in a location that allows ease of opening and closing (in a position where it can be reached quickly in the event of an emergency).

Do not block access to the shutoff valve. The valve is for turning on or shutting off gas to the appliance.

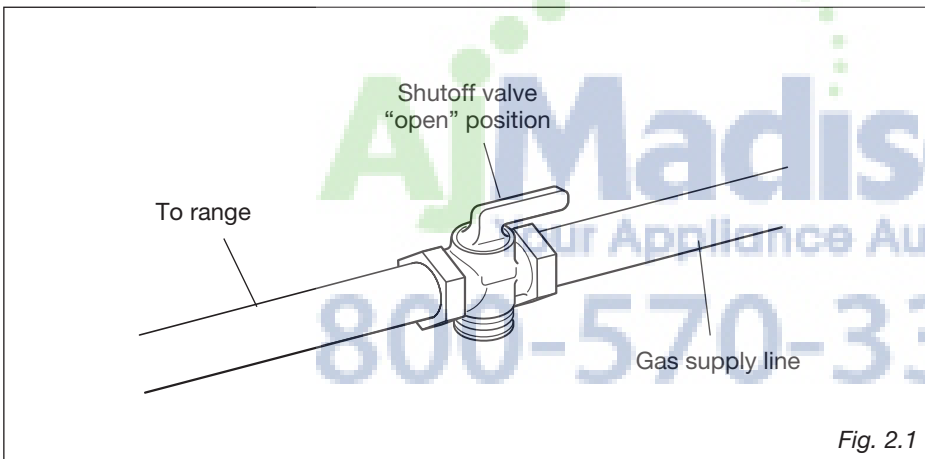

2. Pressure Regulator:

a) All heavy duty, commercial type cooking equipment must have a pressure regulator on the incoming service line for safe and efficient operation, since service pressure may fluctuate with local demand.

Before installing the regulator mount the 1/2" NPT (conical) male connector to the regulator (see picture 2.2a). Gasket supplied have to be placed between 1/2" NPT (conical) connector/extension pipe male pipe fitting (see picture 2.2b).

The regulator supplied with this range must be installed before any gas connections are made.

Use supplied pressure regulator only.

b) Assemble the extension pipe + pressure regulator group to the range manifold interposing the gasket supplied.



WARNING



Explosion Hazard

Use a new CSA or UL approved gas supply line.

Install a shut-off valve.

Securely tighten all gas connections.

If connected to LP, have a qualified person make sure gas pressure does not exceed 14" water column.

Examples of a qualified person include licensed heating personnel, authorized gas company personnel, and authorized service personnel.

Failure to do so can result in death, explosion, or fire.

PRESSURE REGULATOR INSTALLATION

STEP 1

Mount the 1/2" NPT (conical) male connector to the pressure regulator and tighten by using a wrench.

Do not over tighten the connector.

Over tightening may crack regulator.

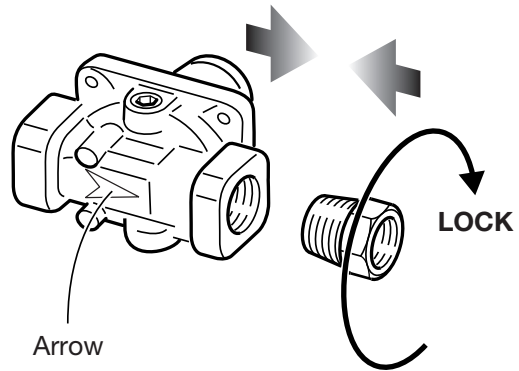

Fig. 2.2a

STEP 2

Assemble the 1/2" NPT connector + pressure regulator group to the extension pipe interposing the gasket supplied. The regulator cover must be oriented toward the front side of the range.

IMPORTANT: use two spanners to tighten the connection.

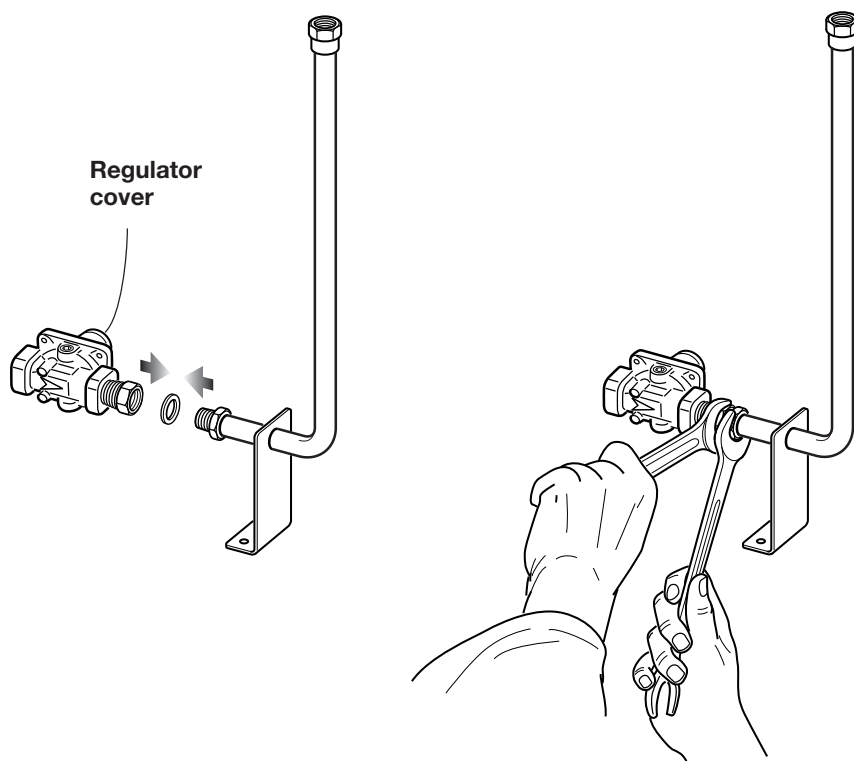

Fig. 2.2b

AjMadison
The Authority™
800-570-3355

STEP 3

Insert the extension pipe + pressure regulator group in the "A" bracket.

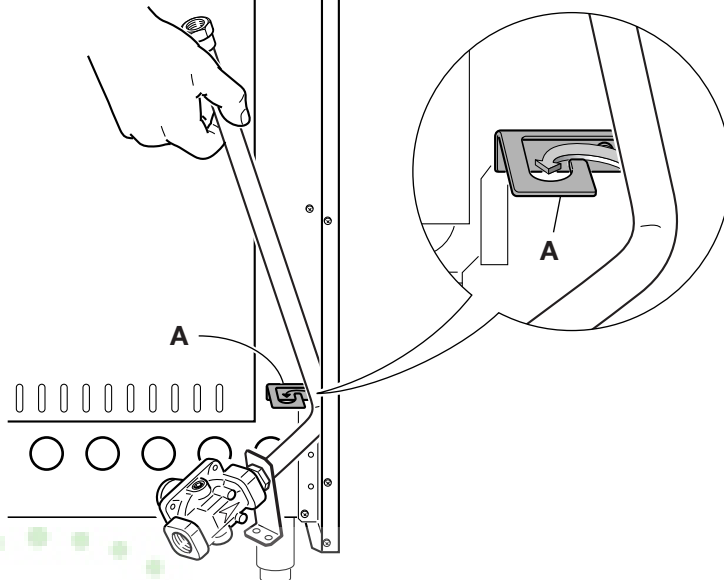

Fig. 2.2c

STEP 4

Assemble the extension pipe + pressure regulator group to the range manifold interposing the gasket supplied. The regulator cover must be oriented toward the front side of the range.

IMPORTANT: use two spanners to tighten the connection.

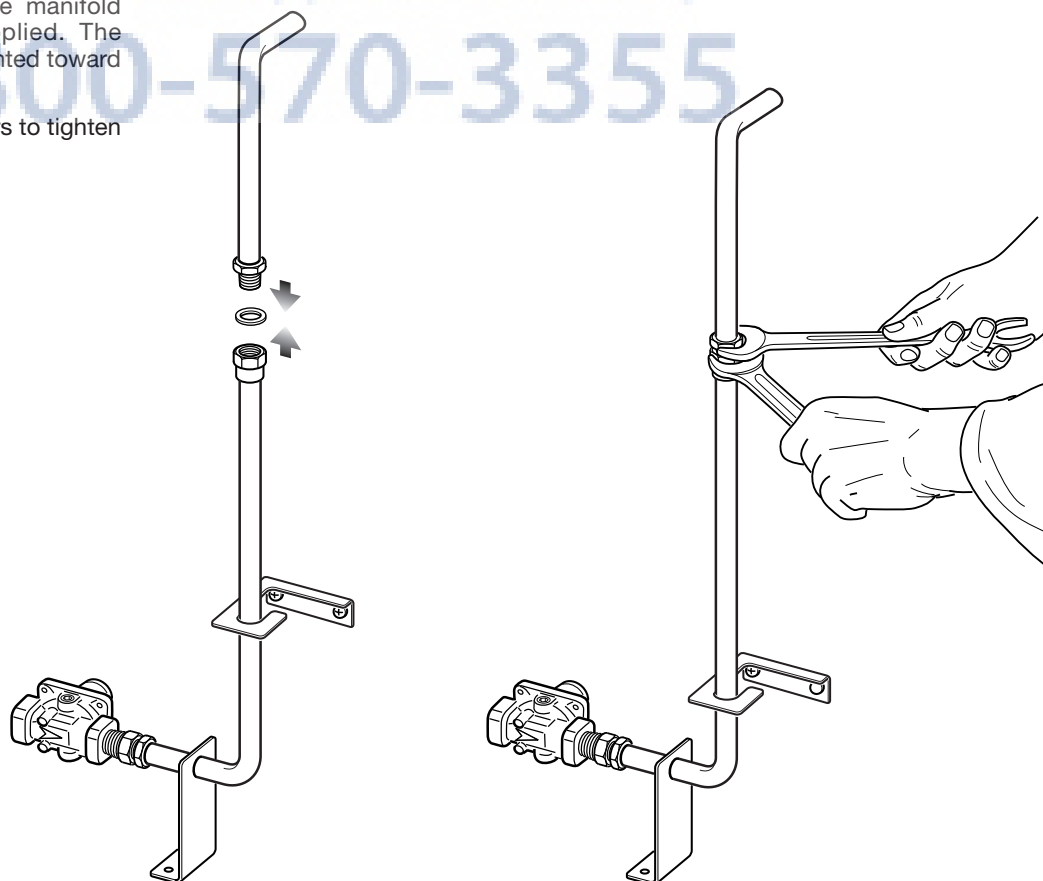

Fig. 2.2d

②

STEP 5

Fix the "B" bracket on the back of the range by the 2 (two) screws supplied with the kit for gas connection.

The regulator cover must be oriented toward the front side of the range.

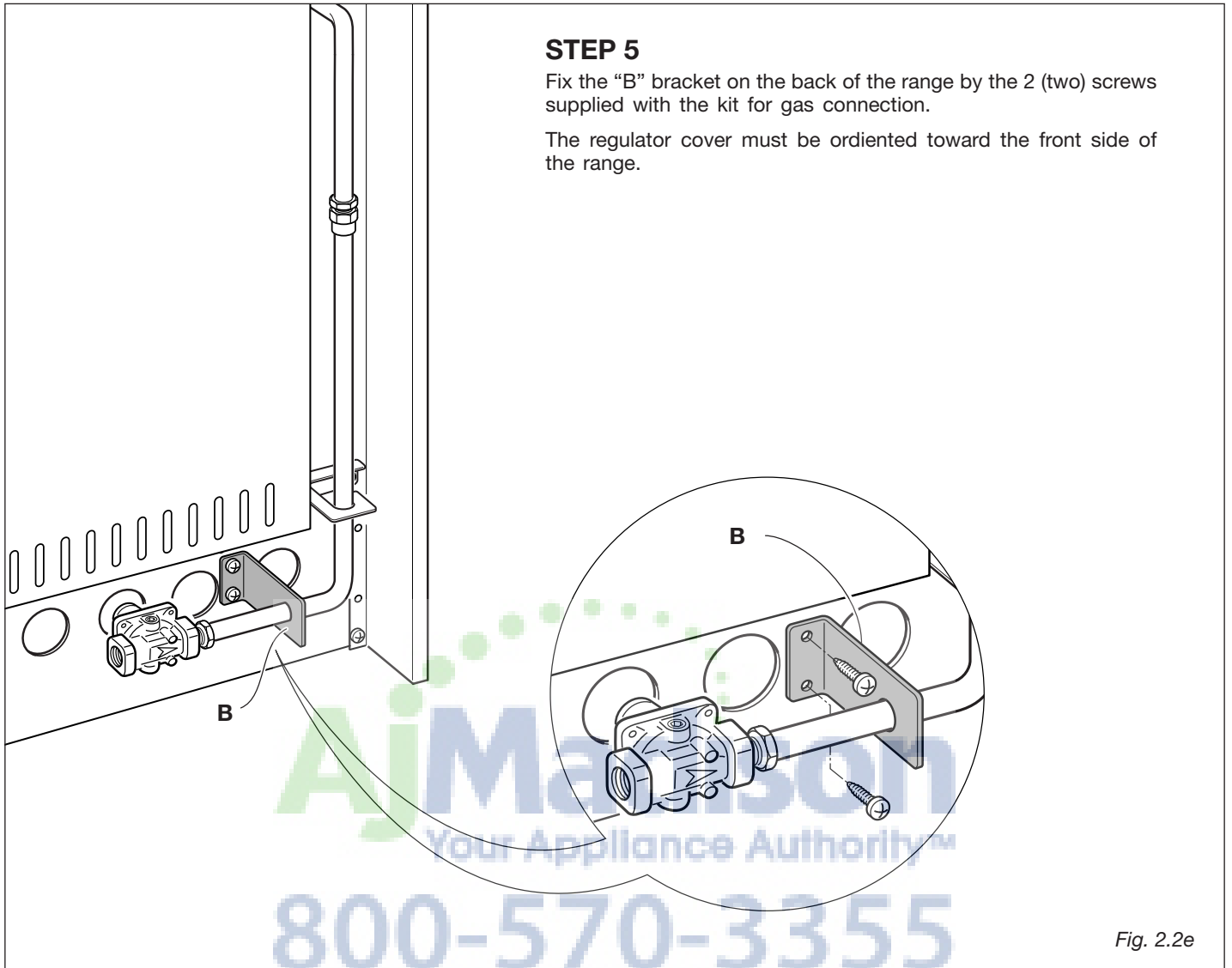

Fig. 2.2e

GAS CONNECTION SPECIFICATION

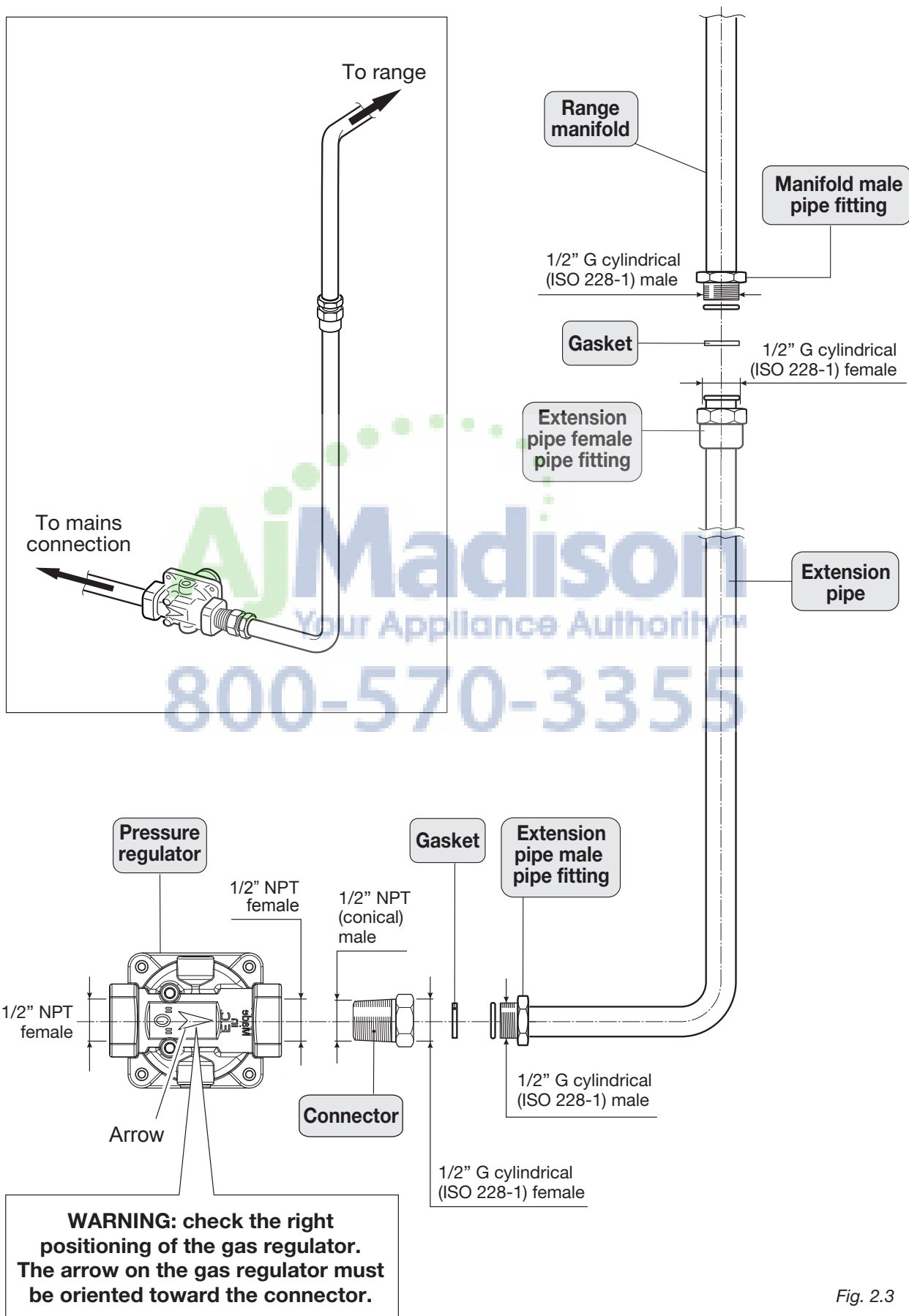

Fig. 2.3

TEST POINT ADAPTER

The Test Point adapter is available from the After-Sales Service.

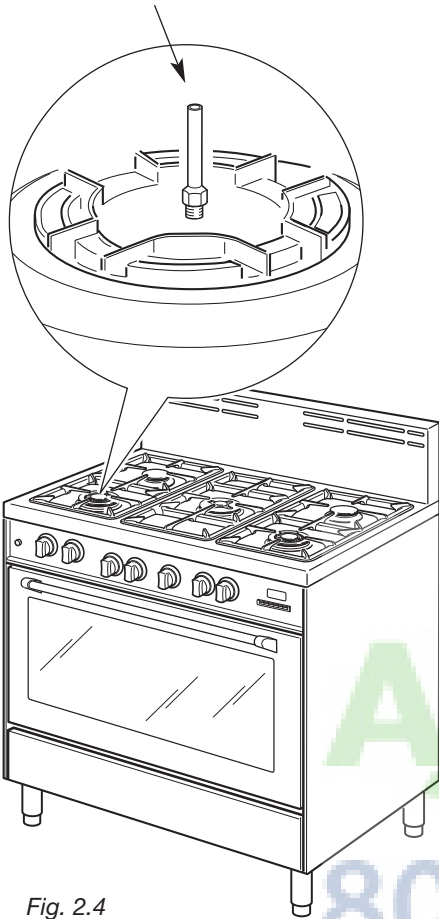

Fig. 2.4

- c) Any conversion required must be performed by your dealer or a qualified licensed plumber or gas service company. Please provide the service person with this manual before work is started on the range. (Gas conversions are the responsibility of the dealer or end user.)
- d) This range can be used with NATURAL or LP/PROPANE gas. It is shipped from the factory adjusted for use with NATURAL gas.
- e) Manifold pressure should be checked with a manometer and by operating as below detailed:
- Remove the injector from the front left burner and mount the proper test point adapter which is available from the After-Sales Service (see side figure and the "OPERATIONS TO BE PERFORMED WHEN SUBSTITUTING THE INJECTORS" chapter).
 - Turn the front left burner control knob to the maximum position (★ III position)
 - Press the knob and keeping it pressed check the manifold pressure with a manometer; NATURAL gas requires 4.0" W.C.P. and LP/PROPANE requires 11.0" W.C.P.
 - Incoming line pressure upstream from the regulator must be 1" W.C.P. higher than the manifold pressure in order to check the regulator.
 - The regulator used on this range can withstand a maximum input pressure of 1/2 PSI (14.0" W.C.P). If the line pressure is in excess of that amount, a step-down regulator will be required.
- f) The appliance, its individual shut-off valve, and pressure regulator must be disconnected from the gas supply piping system during any pressure testing of that system at pressures in excess of 1/2 PSI (3.5 kPa).
- g) The appliance must be isolated from the gas supply piping system by closing its individual manual shut-off valve during any pressure testing of the gas supply piping system at test pressure equal to or less than 1/2 PSI (3.5 kPa).

3. Flexible Connections:

If local codes permit, CSA design-certified, flexible metal appliance connector is recommended for connecting this range to the gas supply line. Do Not kink or damage the flexible connector when moving the range. The pressure regulator has 1/2" NPT female pipe threads. You will need to determine the fittings required, depending on the size of your gas supply line, flexible metal connector and shutoff valve.

4. Rigid Pipe Connections:

If rigid pipe is used as a gas supply line, a combination of pipe fittings must be used to obtain an in-line connection to the range. All strains must be removed from the supply and fuel lines so range will be level and in line.

- Use joint compounds and gaskets that are resistant to action of natural or propane gas on all male pipe threads.
- Do not over tighten gas fitting when attaching to pressure regulator. Over tightening may crack regulator.

5. Leak Testing:

IMPORTANT: Leak testing of the appliance shall be conducted as follows:

- After final gas connection is made, turn on manual gas valve and test all connections in gas supply piping and appliance for gas leaks with a soapy water solution. During this test all appliance gas valves have to be closed.
- In order to avoid property damage or serious personal injury, never use a lighted match. If a leak is present, tighten joint or unscrew, apply more joint compound, tighten again and retest connection for leak.

CONVERSION TO LP/PROPANE GAS

Every range is provided with a set of injectors for the various types of gas. Select the injectors to be replaced according to the "INJECTORS TABLE". The nozzle diameters, expressed in hundredths of a millimetre, are marked on the body of each injector.

SETTING THE PRESSURE REGULATOR (fig. 2.5)

The pressure regulator is accessible through the storage compartment by opening the bottom pivoting panel; the pressure regulator is positioned on the rear left side of the range.

To set the pressure regulator:

1. Unscrew the regulator cover;
2. Unscrew the A component, reverse and screw it according to the LP/PROPANE regulation.

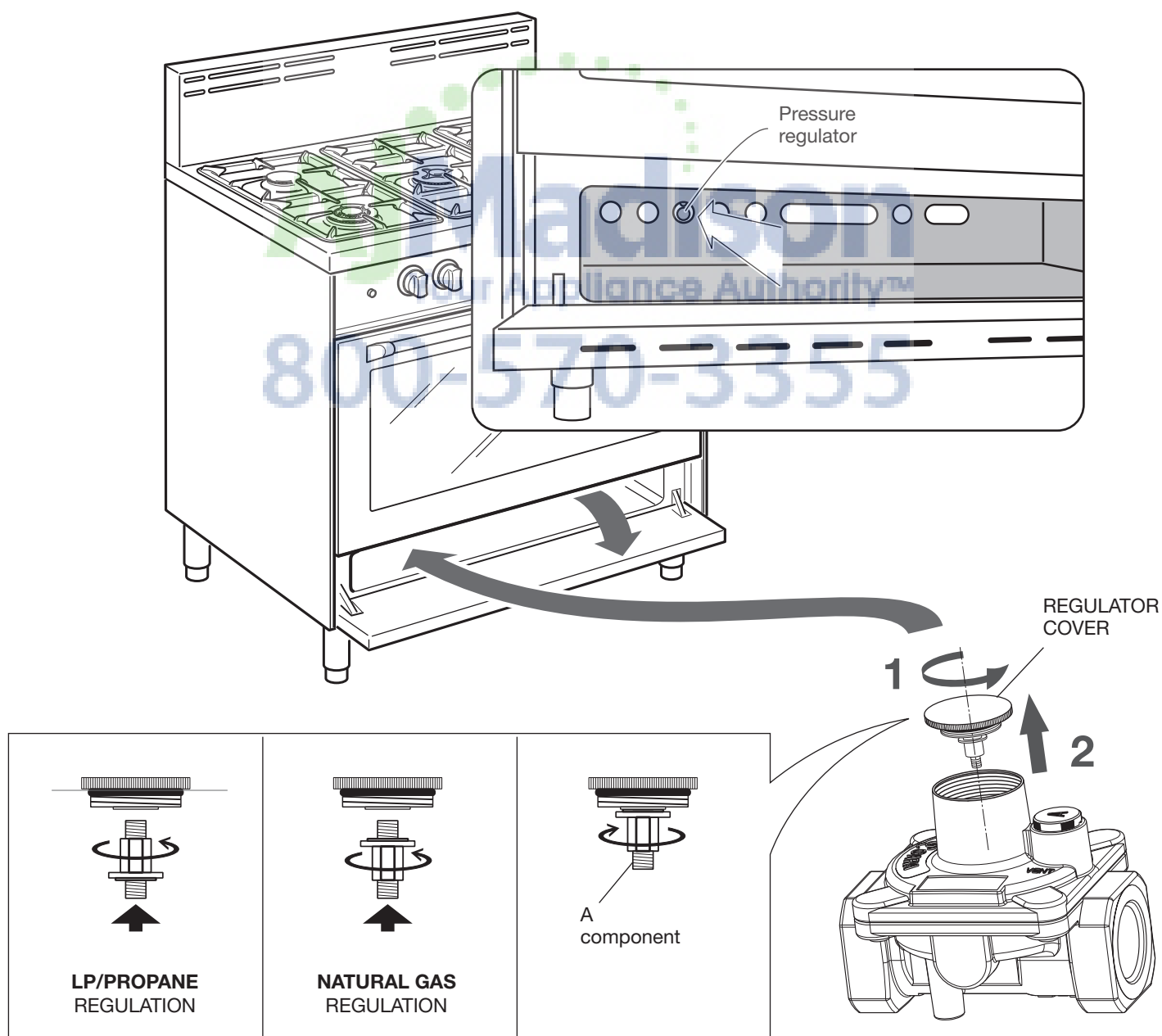

Fig. 2.5

INJECTORS TABLE

BURNERS		NOMINAL POWER BTU/hr	REDUCED POWER BTU/hr	LP/PROPANE 11" W.C.P.	NATURAL GAS 4" W.C.P.
				Ø injector [1/100 mm]	Ø injector [1/100 mm]
Semi-rapid (R)		6000	1500	72	118
Triple ring (TC)		12000	5000	102	170
Dual (D)	Inner crown	2800 for NATURAL GAS (*) 3500 for LP/PROPANE GAS (*)	1000 (*)	55 (no. 1 central)	80 (no. 1 central)
	Outer crowns	16000 for NATURAL GAS (#) 15000 for LP/PROPANE GAS (#)	6500 for NATURAL GAS (#) 4500 for LP/PROPANE GAS (#)	72 (no. 2 outer)	130 (no. 2 outer)

(*) Power calculated only with inner crown operating

(#) Power calculated with inner and outer crowns operating

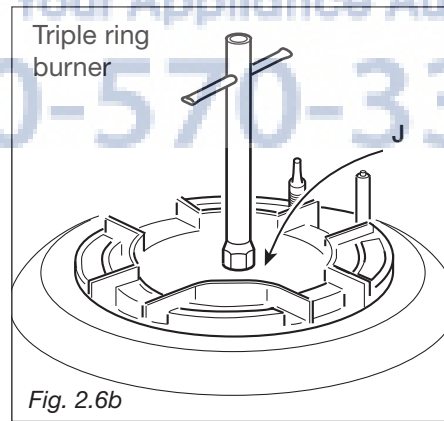
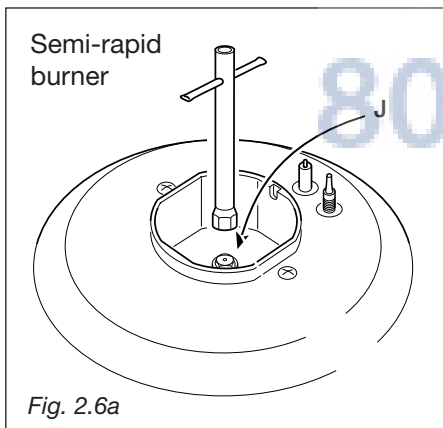

OPERATIONS TO BE PERFORMED WHEN SUBSTITUTING THE INJECTORS

- ✓ Remove the gratings and the burner covers;
- ✓ Using a wrench substitute the nozzle injectors "J" (figs. 2.6a - 2.6b - 2.6c) with those most suitable for the kind of gas for which it is to be used.

The burner are conceived in such a way so as not to require the regulation of the primary air.

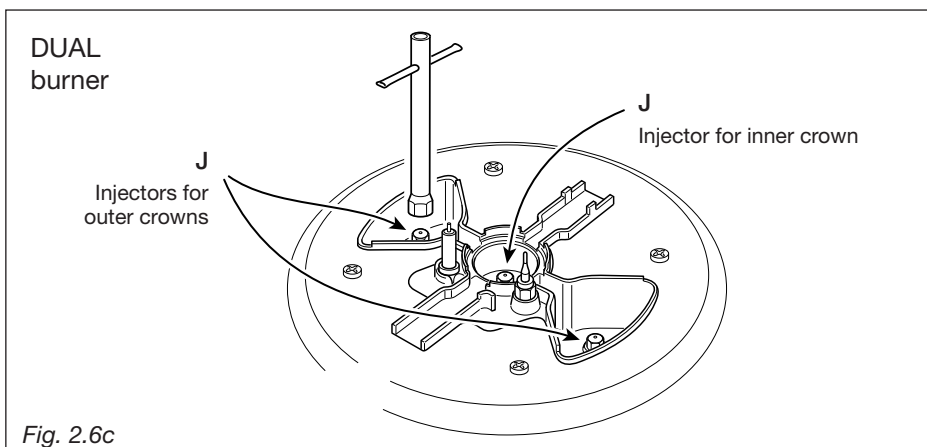

SETTING THE BURNER MINIMUM

When switching from one type of gas to another, the minimum flow rate must also be correct: the flame should not go out even when passing suddenly from maximum to minimum flame.

To regulate the flame follow the instructions below:

Semirapid and triple ring burners

- Light the burner
- Set the gas valve to **L0** position
- Remove the knob
- With a thin screwdriver turn the screw **F** until adjustment is correct (fig. 2.7).

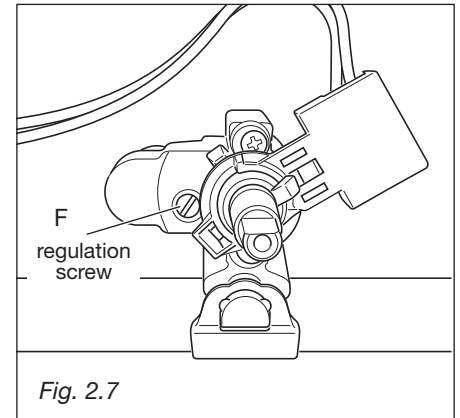

Inside crown of DUAL burner

- Light the DUAL burner
- Set the gas valve to **SIM** position
- Remove the knob
- Using a screwdriver turn the screw **H** until the correct setting is obtained (fig. 2.8).

Outside crowns of DUAL burner

- Light the DUAL burner
- Set the gas valve to **L0** position
- Remove the knob
- Using a screwdriver turn the screw **G** until the correct setting is obtained (fig. 2.8).

For LP/PROPANE gas, tighten the adjustment screws completely.

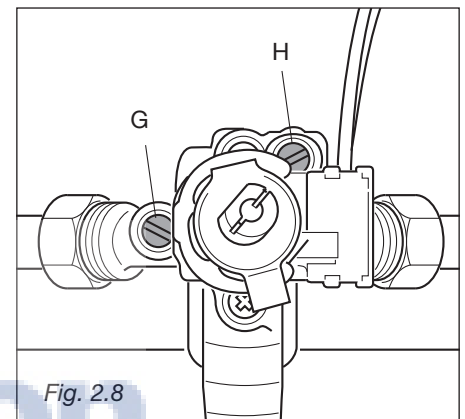

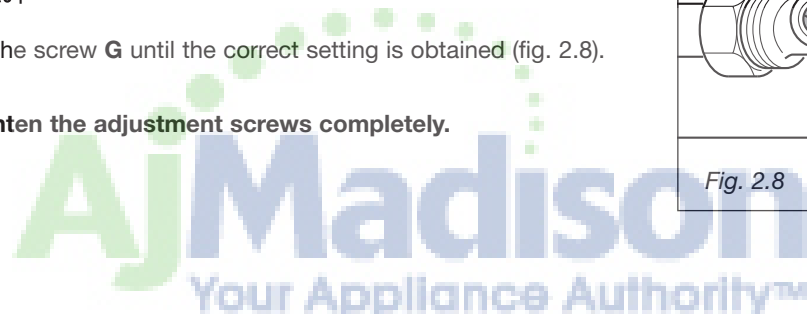

 Your Appliance Authority™

 800-570-3355



WARNING

TO AVOID ELECTRICAL SHOCK HAZARD, BEFORE INSTALLING THE APPLIANCE, SWITCH POWER OFF AT THE SERVICE PANEL AND LOCK THE PANEL TO PREVENT THE POWER FROM BEING SWITCHED ON ACCIDENTALLY.

ELECTRICAL REQUIREMENTS

- This appliance must be properly installed and grounded by a qualified technician in accordance with the National Electrical Code ANSI/NFPA No.70 (latest edition) and local electrical code requirements. IN CANADA: Electrical installation must be in accordance with the current CSA C22.1 Canadian Electrical Codes Part1 and/or local codes.
- This appliance may be connected by means of permanent “Hard Wiring” or “Power Supply Cord Kit”. Power supply cord is not supplied, but it is available through your local electric supply house.
- Use only 3-conductor or 4-conductor CSA/UL listed range cord rated at 30 amps with 250 V minimum and provided with ring terminals. These cords should be provided with strain relief or conduit connector.

Warning: Frame grounded through neutral lead. If used in,

- New branch-circuit installations (1996 NEC),
- Mobile homes,
- Recreational vehicles, or
- In an area where local codes prohibit grounding through neutral, use a 4 conductor cord or conduit.
- The range must be connected to the proper electrical voltage and frequency as specified on the rating plate.
- The range can be connected directly to the fused disconnect (or circuit breaker box) through flexible, armoured or non-metallic sheathed, copper cable (with grounding wire). Allow two to three feet of slack in the line so that it can be moved if servicing is ever necessary.

AjMadison
Your Appliance Authority™

800-570-3355

ELECTRICAL CONNECTION WITH POWER CORD

Use a 3-wire power supply cord kit rated for 30 amps - 125/250 volts with closed loop terminals and marked for use with ranges. Where local codes do not permit grounding through neutral, use a 4-wire power supply cord kit.

The cord must be secured to the range with a suitable strain relief. The electrical connection is made at the terminal block, which is located behind the terminal block access plate on the back of the range.

ELECTRICAL CONNECTION WITH CONDUIT

Use 1/2" (1.3 cm) trade size CSA/UL-listed conduit with a conduit clamp, 16 AWG/600 volt copper conductor colored red for line 1 and black for line 2 and 16 AWG/600 volt copper conductor (or 12 AWG/600 Volt copper conductor if grounding through neutral) colored white for neutral with closed loop terminals marked for use with ranges.

Where local codes do not permit grounding through neutral, use a green 12 AWG copper conductor as directed in the 4-wire connector directions. The conduit must be secured to the range with the strain relief bracket. The electrical connection is made at the terminal block which is located behind the terminal block access plate on the back of the range.

3-Wire Power Cord Installation

(See Figures 3.1, 3.2 and 3.3)

1. Remove the **Terminal Block Access Plate** on the back of the range by unscrewing the 6 fixing **Screws** (fig. 3.1).
 2. Insert the **Power Cord** through the hole in the **Power Cord Bracket**; then tighten the **Power Cord** by using a suitable **Strain Relief**. Allow enough slack to easily attach the cord terminals to the **Terminal Block**.
 3. Remove the 3 wire terminal nuts and washers from the **Terminal Block**.
 4. Plug the terminal holes of **Power Cord**. The **Neutral or Ground Wire** of the **Power Cord** must be connected to the neutral terminal located in the center of **Terminal Block**. The **Power Wires** must be connected to the outside terminals.
 5. Plug washers and tighten nuts securely.
-  Do not remove **Ground strap**.
6. Assemble the **Terminal Block Access Plate**.

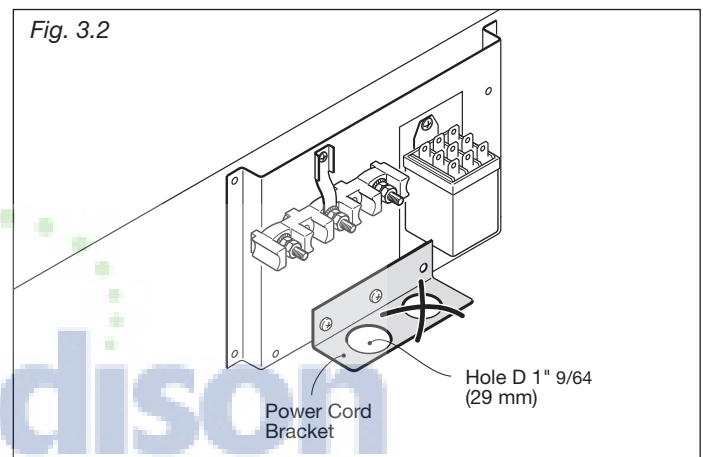
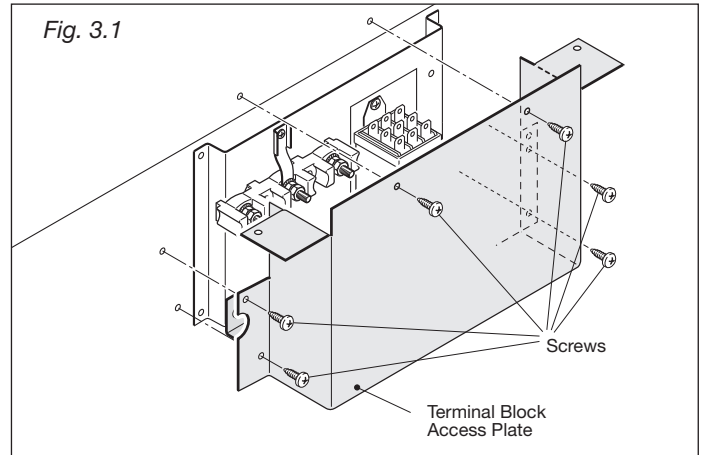

4-Wire Power Cord Installation

(See Figures 3.1, 3.2 and 3.4)

1. Remove the **Terminal Block Access Plate** on the back of the range by unscrewing the 6 fixing **Screws** (fig. 3.1).
2. Insert the **Power Cord** through the hole in the **Power Cord Bracket**; then tighten the **Power Cord** by using a suitable **Strain Relief**. Allow enough slack to easily attach the cord terminals to the **Terminal Block**.
3. Remove the 3 wire terminal nuts and washers from the **Terminal Block**.
4. Remove the **Ground Strap** from the frame of range and terminal by removing its screw and cutting it as shown in Figure 3.4.
5. Plug the terminal holes of **Power Cord**. The **Neutral Wire** of the **Power Cord** must be connected to the neutral terminal located in the center of **Terminal Block**; the **Power Wires** must be connected to the outside terminals; the **Ground Wire** must be attached to the frame of range by using the \perp (Ground) identified **Grounding Screw**.
6. Plug washers and tighten nuts securely.
7. Assemble the **Terminal Block Access Plate**.

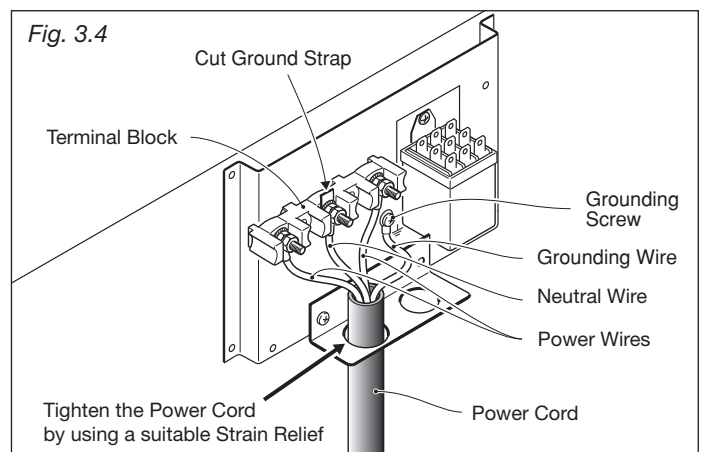
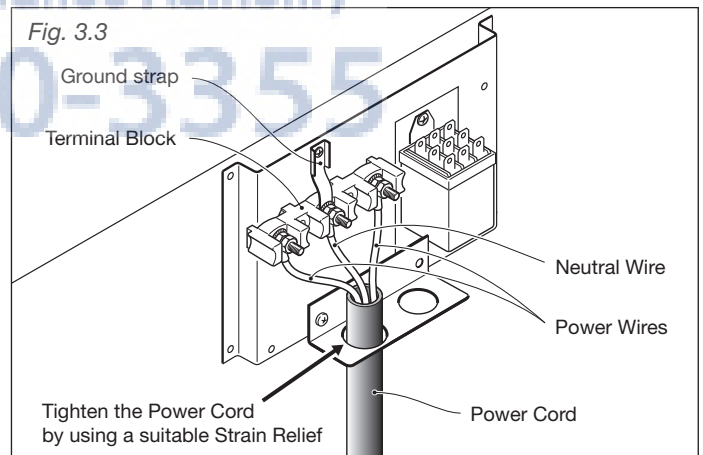

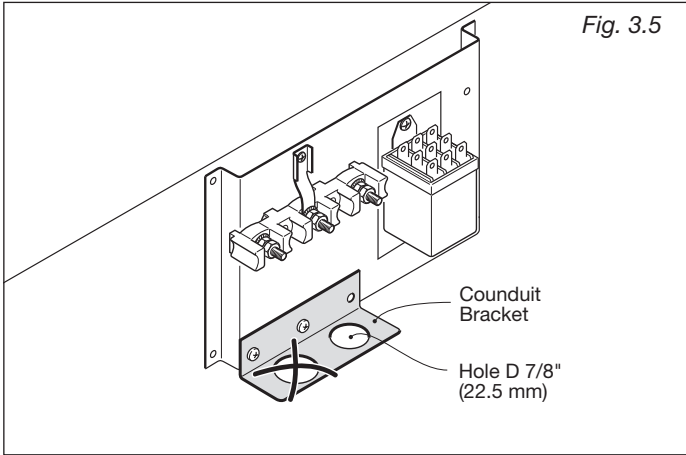

3-Wire Conduit Installation

(See Figures 3.1, 3.5 and 3.6)

1. Remove the **Terminal Block Access Plate** on the back of the range by unscrewing the 6 fixing **Screws** (fig. 3.1).
2. Feed 1/2" (1.3 cm) trade size **Conduit** through the hole in the **Conduit Bracket** and secure to the **Conduit Bracket** with a **Conduit Clamp**.
3. Remove the 3 wire terminal nuts and washers from the **Terminal Block**.
4. Plug the terminal holes of conductors. The **Neutral or Ground Wire** of the **Power Cord** must be connected to the neutral terminal located in the center of **Terminal Block**. The **Power Wires** must be connected to the outside terminals.
5. Plug washers and tighten nuts securely.



Do not remove **Ground strap**.

6. Assemble the **Terminal Block Access Plate**.

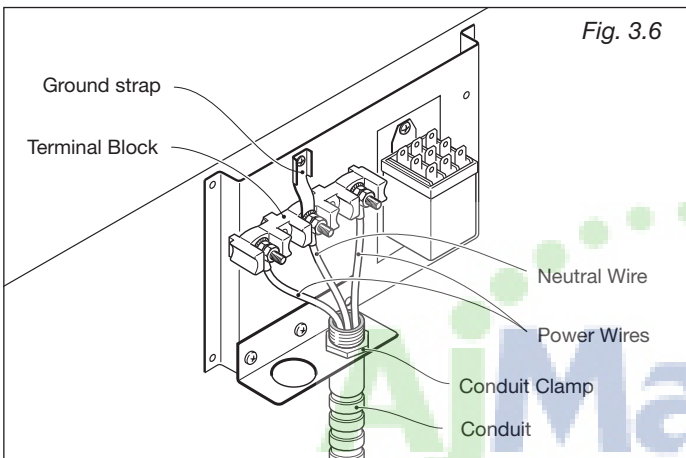

4-Wire Conduit Installation

(See Figures 3.1, 3.5 and 3.7)

1. Remove the **Terminal Block Access Plate** on the back of the range by unscrewing the 6 fixing **Screws** (fig. 3.1).
2. Feed 1/2" (1.3 cm) trade size **Conduit** through the hole in the **Conduit Bracket** and secure to the **Conduit Bracket** with a **Conduit Clamp**.
3. Remove the 3 wire terminal nuts and washers from the **Terminal Block**.
4. Remove the **Ground Strap** from the frame of range and terminal by removing its screw and cutting it as shown in Figure 3.7.
5. Plug the terminal holes of conductors. The **Neutral Wire** of the **Power Cord** must be connected to the neutral terminal located in the center of **Terminal Block**; the **Power Wires** must be connected to the outside terminals; the **Ground Wire** must be attached to the frame of range by using the \perp (Ground) identified **Grounding Screw**.
6. Plug washers and tighten nuts securely.
7. Assemble the **Terminal Block Access Plate**.

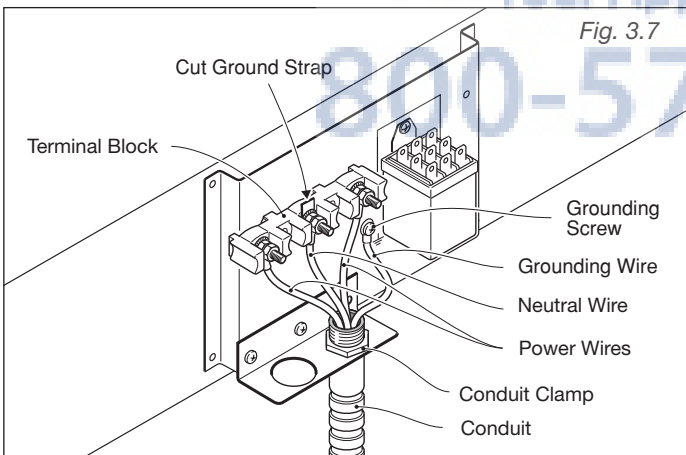

WIRING DIAGRAM

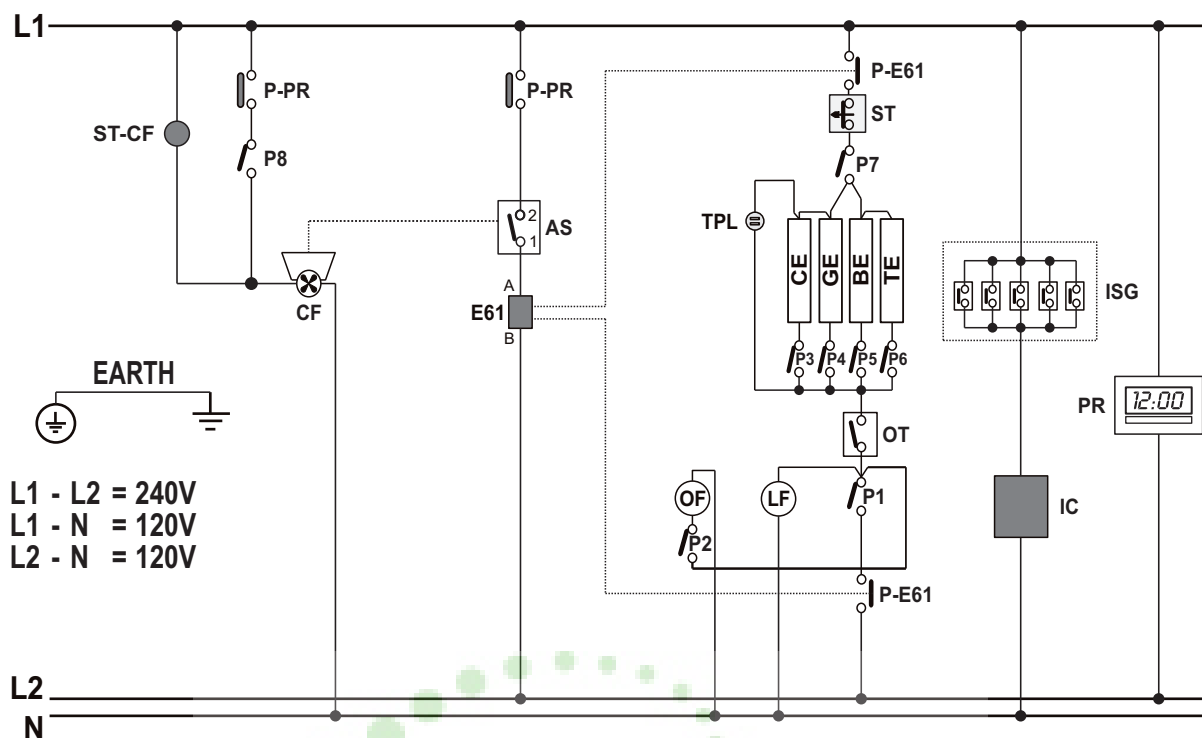

L1 - L2 = 240V
 L1 - N = 120V
 L2 - N = 120V

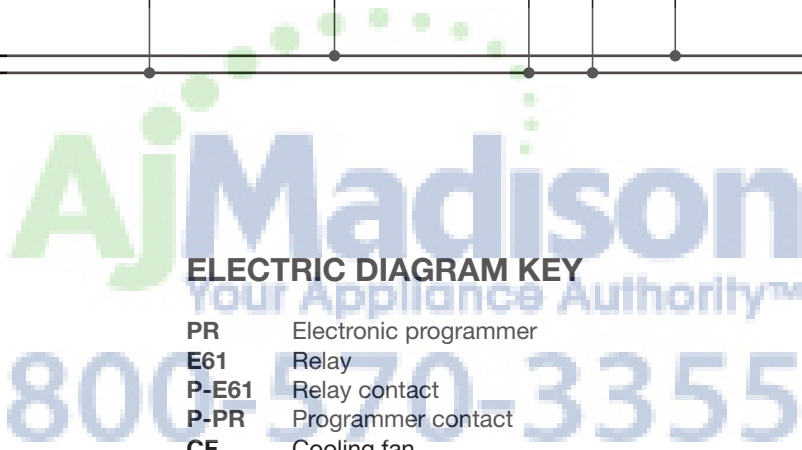

ELECTRIC DIAGRAM KEY

- PR Electronic programmer
- E61 Relay
- P-E61 Relay contact
- P-PR Programmer contact
- CF Cooling fan
- P1...8 Oven switch contact
- AS Air flow switch
- OF Oven fan
- TPL Thermostat pilot lamp
- CE Circular element
- GE Broil element
- BE Bottom element
- TE Top element
- OT Oven thermostat
- ST Safety thermal overload
- ST-CF Cooling fan thermal overload
- LF Oven lamp
- ISG Ignition switches group
- IC Ignition coil





The manufacturer cannot be held responsible for possible inaccuracies due to printing or transcription errors in the present booklet.

The manufacturer reserves the right to make all modifications to its products deemed necessary for manufacture or commercial reasons at any moment and without prior notice, without jeopardising the essential functional and safety characteristics of the appliances.

