

# INSTALLATION INSTRUCTIONS

## TOP-30, TOP-36, TOP-42, TOP-48 TOP PANEL KIT

VIKING RANGE CORPORATION  
111 Front Street  
Greenwood, Mississippi 38930 USA  
(662)455-1200

For Use with Built-In Refrigerator/Freezers and Full Height Wine Cellars

### IMPORTANT - PLEASE READ AND FOLLOW

- Before beginning, please read these instructions completely and carefully.
- Do not remove permanently affixed labels, warnings or plates from the product. This may void the warranty.
- Please refer to installation instructions included with the product for site preparations and considerations.
- The installer should leave instructions with the consumer who should retain for local inspector's use and for future reference.

**CAUTION:** Always wear gloves when handling top and side panels. Some edges may be sharp enough to cause injury during handling.

### WARNING!

The unit must be fastened to a wall located at the rear of the product. Failure to properly fasten the product to the wall can result in death or serious injury. See installation instructions included with the product for proper securing methods.

### Parts Included:

- (1) Stainless steel top panel
- (6) Stainless steel wafer head screws (Part number - M0210417)
- (2) Wood screws (min 1.5" long) (Part number - PD020016)

### Required Tools:

- Electric drill
- 9/64" (.36 cm) diameter drill bit

### To install top panel with two side panels:

1. The top panel will be fastened to an adjacent wall that is to be located behind the unit. This is to provide an anti-tip device in lieu of the product being placed into a fixed enclosure. The unit should be anchored to wall studs (minimum of two). Before positioning the unit in place, locate the wall studs.
2. Locate the unit in front of the area in which it is to be installed (approximately two feet directly in front of the final position).
3. Place the top panel on top of the unit.
4. Position the side panels behind the cabinet side trim such that the top flanges of the side panels overlap the top panel.
5. Insure that side panels are fully located behind the side trim and that the rear flanges of the panels are making contact with the rear of the unit. (figure 1)
6. Using the 6 stainless steel wafer head screws, attach the side panels to the top panel by screwing through the side panels into the top panel on each side (figure 2)

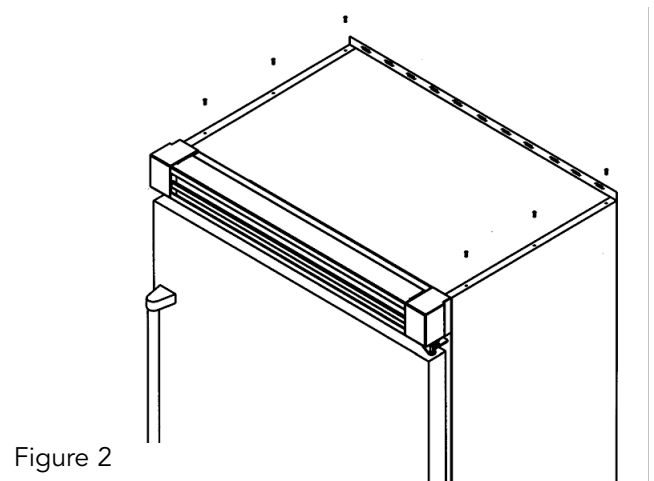
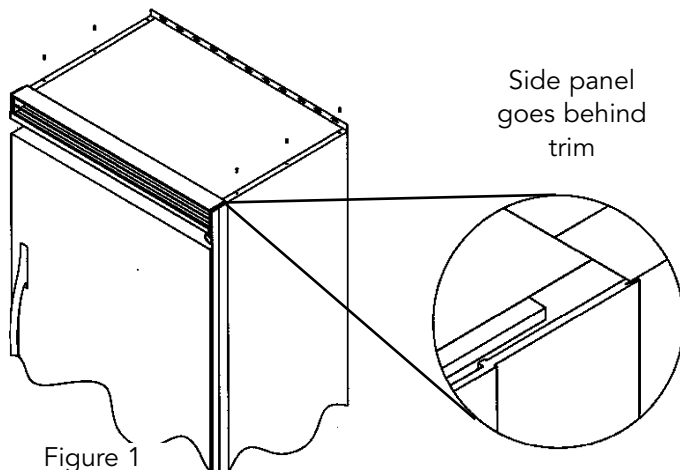

7. Using the panel hole locations as a template, drill ten (10) holes on the cabinet rear with a 9/64" (.36 cm) diameter drill bit. (figure 3)
8. Attach the panel to the rear of the unit using the ten (10) black #8 sheet metal screws provided.
9. Plug unit into the receptacle and roll the unit so that the rear of the unit makes contact with the wall in the final location.
10. Adjust to desired height, and level unit by turning the front and rear leveling wheel bolts clockwise to raise the unit and counterclockwise to lower the unit. Rotate leveling feet until firmly in place against the floor. The unit back should be tightly located against the back wall.
11. Using the top panel rear flange as an attachment device, locate holes in the flange that are aligned with a minimum of two wall studs. (figure 4)
12. Using wood screws that are a minimum of 1½" long, attach the top panel flange to the anchoring device (wall studs or other mechanical device). Ensure that the screw heads will not pull through slots in top panel. Use washer if necessary to prevent pull through.

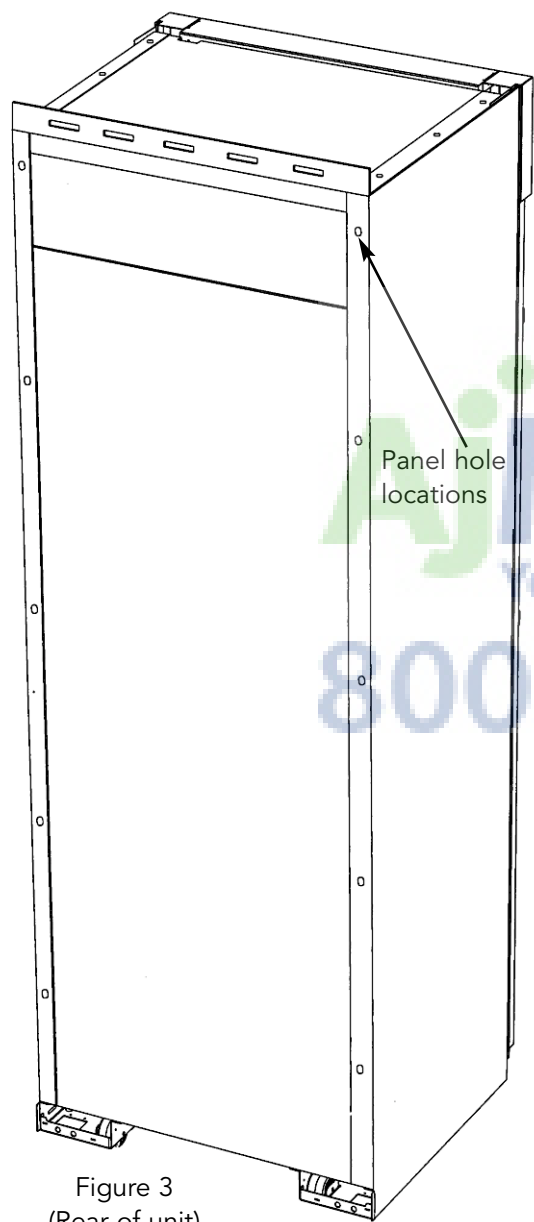

Figure 3  
(Rear of unit)

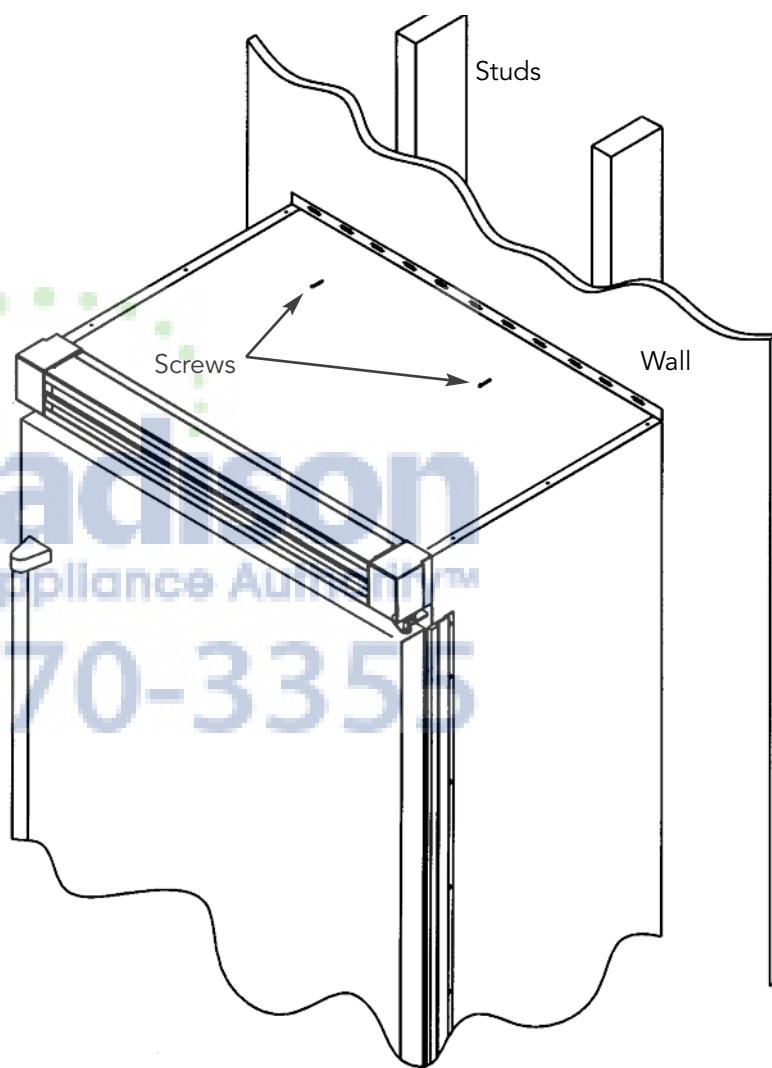

Figure 4

VIKING RANGE CORPORATION  
111 Front Street • Greenwood, Mississippi 38930 USA • (662) 455-1200

Specifications subject to change without notice

For more product information, call 1-888-VIKING1 (845-4641), or visit our web site at [www.vikingrange.com](http://www.vikingrange.com)