

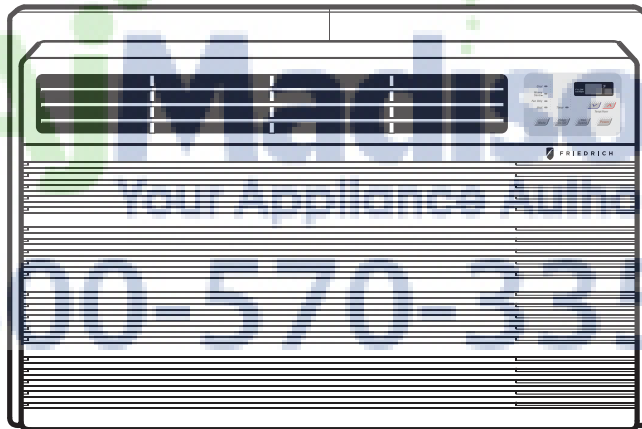

F R I E D R I C H

Uni-Fit[®]
Thru-the-Wall Series
Service and Parts
Manual



Thru-the-Wall Series

230 Volts • UE10C33 UE12C33

115 Volts UE08C13

TABLE OF CONTENTS

Safety Precautions	3
Operating Instructions	7
Controls	7
Remote control	8
Disassembly instructions	9
Mechanical Parts	9
Air Handling Parts	10
Electrical Parts	11
Refrigeration Cycle	13
Schematic Diagram	16
Wiring Diagram	16
Troubleshooting Guide	17
Piping System	17
Troubleshooting Guide	18
Room Air Conditioner Voltage Limits	21
Product specifications	23~25
Exploded View	26
Replacement Parts List	27~29



Safety Precautions

To prevent injury to the user or other people and property damage, the following instructions must be followed.

■ Incorrect operation due to ignoring instruction will cause harm or damage. The seriousness is classified by the following indications.

⚠ WARNING This symbol indicates the possibility of death or serious injury.

⚠ CAUTION This symbol indicates the possibility of injury or damage to property only.

■ Meanings of symbols used in this manual are as shown below.

	Be sure not to do.
	Be sure to follow the instruction.

⚠ WARNING

■ Installation

Don't use a power cord, a plug or a loose socket which is damaged.

• Otherwise, it may cause a fire or electrical shock.



Always plug into a grounded outlet.

• Otherwise, it may cause a fire or electrical shock.

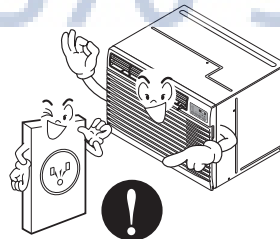

Do not modify or extend the power cord length.

• It will cause electric shock or fire due to heat generation.

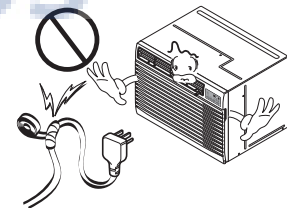

Do not disassemble or modify products.

• It may cause failure and electric shock.



Be caution when unpacking and installing.

• Sharp edges may cause injury.

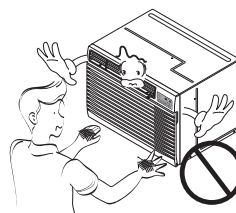

Do not use the power cord near flammable gas or combustibles such as gasoline, benzene, thinner, etc.

• It may cause explosion or fire.

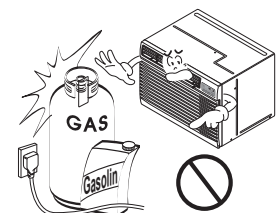

■ Operation

Do not place heavy object on the power cord and take care so that the cord should not be pressed.

- There is danger of fire or electric shock.

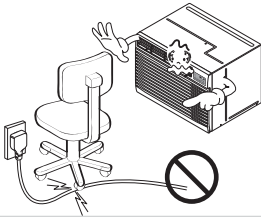

Do not share the outlet with other appliances.

- It will cause electric shock or fire due to heat generation.

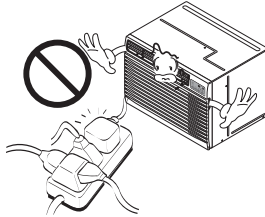

Take the power plug out if necessary, holding the head of the plug and do not touch it with wet hands.

- Otherwise, it may cause a fire or electrical shock.



Do not place the power cord near a heater.

- It may cause fire and electric shock.

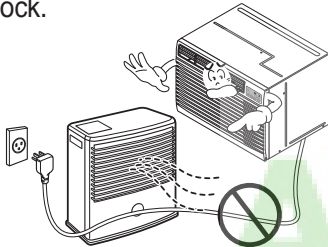

Do not allow water to run into electric parts.

- It will cause failure of machine or electric shock.

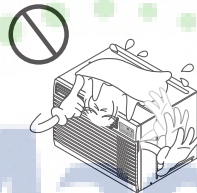

Use a soft cloth to clean. Do not use wax, thinner, or a strong detergent.

- The appearance of the air conditioner may deteriorate, change color, or develop surface flaws.

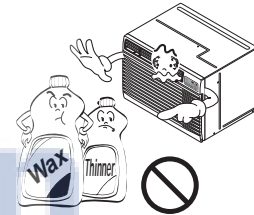

Unplug the unit if strange sounds, odors, or smoke come from it.

- Otherwise it may cause fire and electric shock accident.

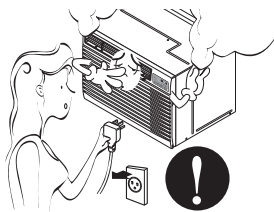

Do not open the suction inlet grill of the product during operation.

- Otherwise, it may electrical shock and failure.

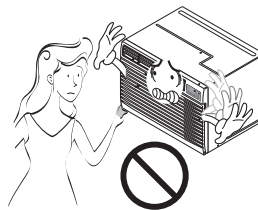

If water enters the product, turn off the the power switch of the main body of appliance. Contact service center after taking the power-plug out from the socket.



■entilate the room well when using this appliance together with a stove, etc.

- An oxygen shortage may occur.

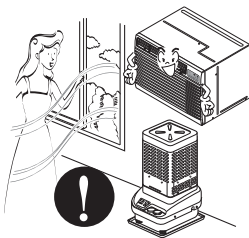

Turn off the power and breaker firstly when cleansing the unit.

- Since the fan rotates at high speed during operation, it may cause injury.

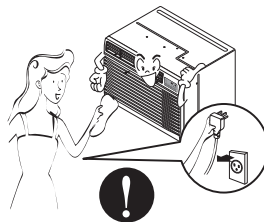

Turn off the main power switch when not using it for a long time.

- Prevent accidental startup and the possibility of injury.

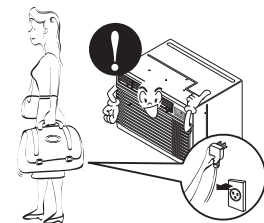

Do not operate or stop the unit by inserting or pulling out the power plug.

- It will cause electric shock or fire due to heat generation.

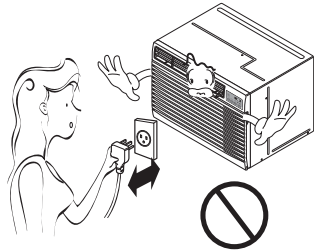

Do not damage or use an unspecified power cord.

- It will cause electric shock or fire.

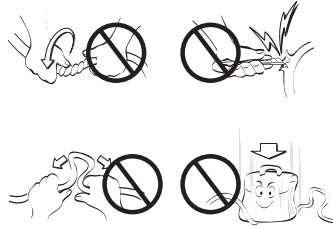

Do not operate with wet hands or in damp environment.

- It will cause electric shock.

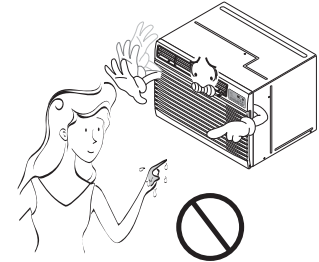

Hold the plug by the head when taking it out.

- It may cause electric shock and damage.



When gas leaks, open the window for ventilation before operating the unit.

- Otherwise, it may cause explosion, and a fire.

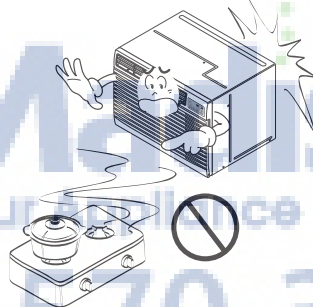

Never touch the metal parts of the unit when removing the filter.

- They are sharp and may cause injury.

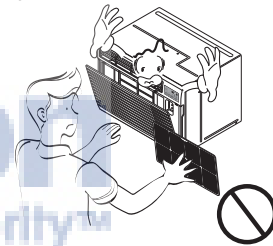

Aj Madison
Your Appliance Authority™
800-570-3355

⚠ CAUTION

■ Installation

Install the product so that the noise or hot wind from the outdoor unit may not cause any damage to the neighbors.

- Otherwise, it may cause dispute with the neighbors.

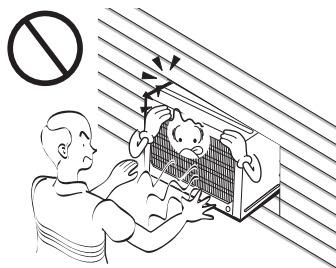

Keep level parallel in installing the product.

- Otherwise, it may cause vibration or water leakage.

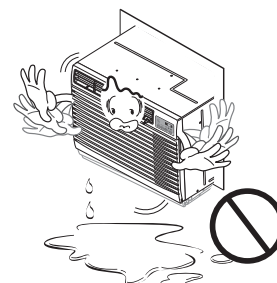

■ Operation

Do not put a pet or house plant where it will be exposed to direct air flow.

- It may cause injury.

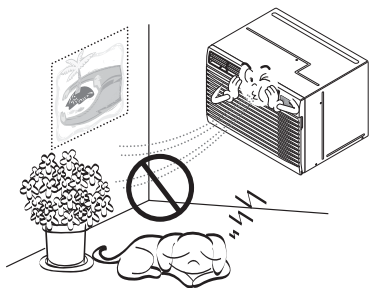

Do not block the inlet or outlet of air flow.

- It may cause product failure.

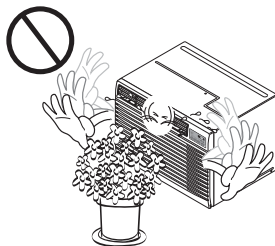

Use a soft cloth to clean. Do not use wax, thinner, or a strong detergent.

- The appearance of the air conditioner may deteriorate, change color, or develop surface flaws.

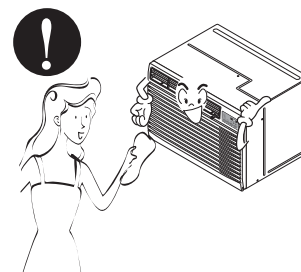

Do not step on the indoor/outdoor unit and do not put anything on it.

- It may cause an injury through dropping of the unit or falling down.

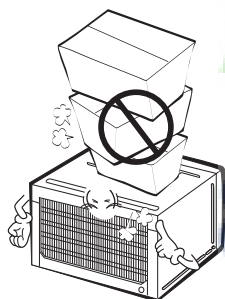

Always insert the filter securely. Clean it every two weeks.

- Operation without filters will cause failure.



Do not drink water drained from air conditioner.

- It contains contaminants and will make you sick.

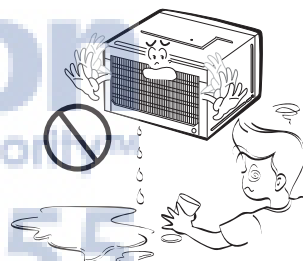

Be cautious not to touch the sharp edges when installing.

- It may cause injury.



Avoid excessive cooling and perform ventilation sometimes.

- Otherwise, it may do harm to your health.

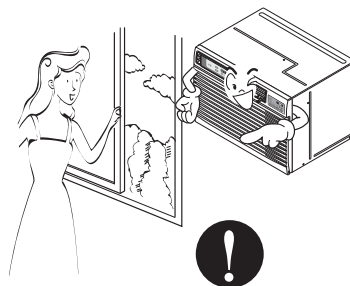

Do not insert the hands or bars through the air inlet or outlet during operation.

- Otherwise, it may cause personal injury.

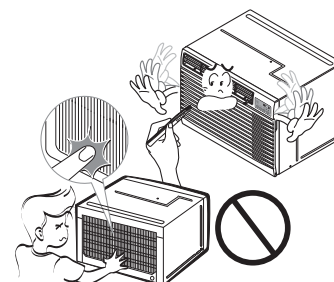

Operating Instructions



Controls

FAN SPEED

- Every time you push this button, it advances the setting as follows: {High[F2] → Low[F1]} → High[F2]

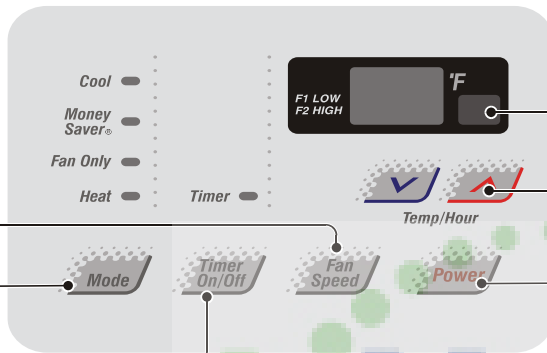

REMOTE CONTROL SIGNAL RECEIVER

TEMPERATURE SETTING

- Use this button to automatically control the temperature of the room.
The temperature can be set within a range of 60°F to 86°F by increments of 1°F.
- The setting appears in the display.

POWER

- To turn the air conditioner ON, push this button. To turn the air conditioner OFF, push the button again.
- This button takes priority over any other button.

TIMER

- SHUT-OFF TIME

- You will usually use shut-off time while you sleep.
- If unit is running, use Timer to set number of hours until shut-off.
- For your sleeping comfort, once Timer is set, the Temperature setting will raise 2°F after 30 min, and once again after another 30 min.
- Push Timer button to advance setting from 1Hour → 2Hour → ... → 12Hours maximum.

- START TIME

- If unit is off, use Timer to set number of hours before unit starts.
- Push Timer button to advance setting from 1Hour → 2Hour → ... → 12Hours maximum.

MODE

- Push this button to shift mode of operation from COOL → MONEY SAVER → FAN ONLY → HEAT

- COOL:

- Fan runs continually for normal cooling operation.

- MONEY SAVER:

- The fan stops when the compressor stops cooling. Approximately every 3 minutes the fan will turn on and the unit will check the room air temperature to determine if cooling is needed.

- FAN ONLY:

- Fan-only operation.

- HEAT:

- Fan runs continually for normal heating operation.

AUTO RESTART

When power is restored after an electrical power failure, the unit will begin to run at its last setting.



REMOTE CONTROL

POWER

- To turn the air conditioner ON, push this button.
- To turn the air conditioner OFF, push the button again.
- This button takes priority over any other button.

TEMPERATURE SETTING

- Use this button to automatically control the temperature of the room.
The temperature can be set within a range of 60°F to 86°F by increments of 1°F.
- The setting appears in the display.

FAN SPEED

- Every time you push this button, it advances the setting as follows:
{High[F2] → Low[F1]} → High[F2]

TIMER

- SHUT-OFF TIME

- You will usually use shut-off time while you sleep.
- If unit is running, use Timer to set number of hours until shut-off.
- For your sleeping comfort, once Timer is set, the Temperature setting will raise 2°F after 30 min, and once again after another 30 min.
- Push Timer button to advance setting from 1Hour → 2Hour → ... → 12Hours maximum.

- START TIME

- If unit is off, use Timer to set number of hours before unit starts.
- Push Timer button to advance setting from 1Hour → 2Hour → ... → 12Hours maximum.

MODE

- Push this button to shift mode of operation from COOL → MONEY SAVER → FAN ONLY → HEAT

- COOL:

- Fan runs continually for normal cooling operation.

- MONEY SAVER:

- The fan stops when the compressor stops cooling. Approximately every 3 minutes the fan will turn on and the unit will check the room air temperature to determine if cooling is needed.

- FAN ONLY:

- Fan-only operation.

- HEAT:

- Fan runs continually for normal heating operation.

⚠ CAUTION

When the air conditioner has been performed its cooling or heating operation and is turned off or set to the fan position, wait at 3 minutes before resetting to the cooling operation again.

A slight heat odor may come from the unit when first switching to HEAT after the cooling season is over. This odor, caused by fine duct particles on the heater, will disappear quickly. This is harmless.

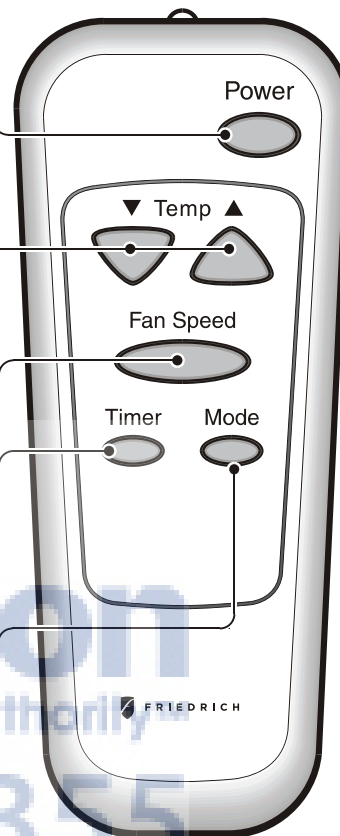

Disassembly Instructions

— Before the following disassembly, POWER SWITCH is set to OFF and disconnected the power cord.

Mechanical Parts

1. FRONT GRILLE

1. Open the inlet grille upward or downward.
2. Remove the screw which fastens the front grille.
3. Pull the front grille from the right side.
4. Remove the front grille. (See Fig. 1)
5. Re-install the component by referring to the removal procedure.

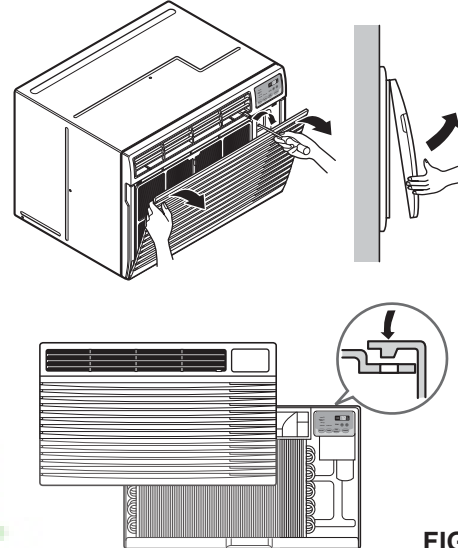

FIG. 1

2. CABINET

1. After disassembling the FRONT GRILLE, remove the 9 screws which fasten the cabinet at the both sides and the top. (See Fig. 2)
Keep these for later use.

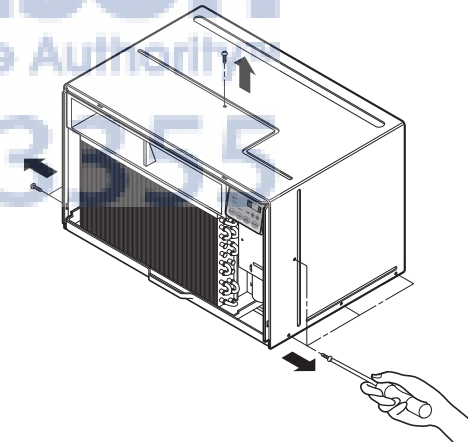

FIG. 2

□ CONTROL BO □

1. Remove the front grille. (Refer to section 1)
2. Remove the screw which fasten the control box. (See Fig. 3)
3. Pull the control box from the barrier. (See Fig. 3)
4. Discharge the capacitor by placing a 20,000 ohm resistor across the capacitor terminals.
5. Disconnect two wire housings in the control box.
6. Pull the control box forward completely.
7. Re-install the components by referring to the removal procedure. (See Fig. 3)
(Refer to the circuit diagram found on pages 24 in this manual and on the control box.)

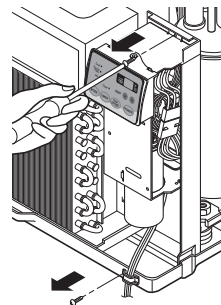

FIG. □

Air Handling Parts

□ ORIFICE, HEATER ASS□ AND TURBO FAN

1. Remove the front grille. (Refer to section 1)
2. Remove the cabinet. (Refer to section 2)
3. Remove the 2 screws which fasten the evaporator at the left side and the right side. (See Fig. 4)
4. Move the evaporator sideward carefully.
5. Remove the 2 terminals carefully (See Fig. 28, at Electric Heater Model only)
6. Remove the 4 screws which fasten the orifice. (See Fig. 5)
7. Remove the orifice. (See Fig. 5)

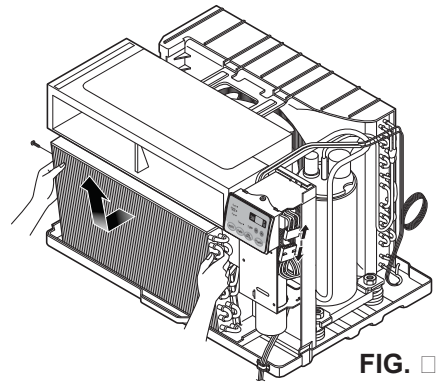

FIG. □

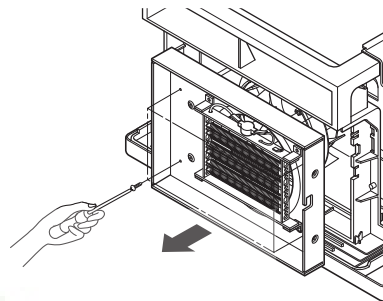

FIG. □

8. Remove the clamp which secures the turbo fan with plier. (See Fig. 6)

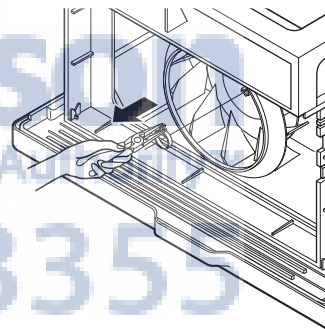

FIG. □

9. Remove the turbo fan with plier or your hand without touching blades. (See Fig. 7)
10. Re-install the components by referring to the removal procedure, above.

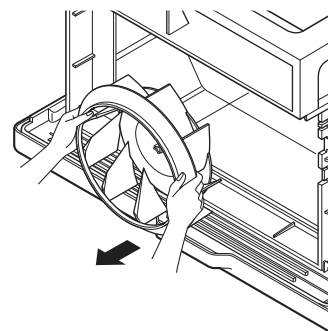

FIG. □

□ FAN

1. Remove the cabinet. (Refer to section 2)
2. Remove the brace and shroud cover. (Refer to section 4)
3. Remove the 6 screws which fasten the condenser.
4. Move the condenser sideways carefully.
5. Remove the clamp which secures the fan.
6. Remove the fan. (See Fig. 8)
7. Re-install the components by referring to the removal procedure, above.

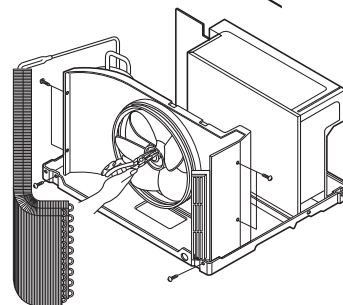

FIG. □

SHROUD

1. Remove the fan. (Refer to section 5)
2. Remove the screw which fasten the shroud.
3. Remove the shroud. (See Fig. 9)
4. Re-install the component by referring to the removal procedure, above.

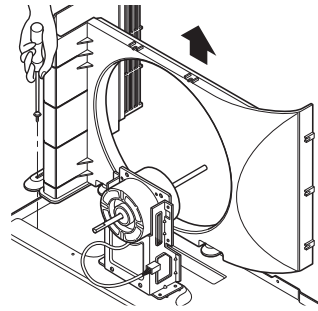

FIG. 9

Electrical Parts**MOTOR**

1. Remove the cabinet. (Refer to section 2)
2. Remove the clamp cord and disconnect a wire housing in control box. (Refer to section 3)
3. Remove the turbo fan. (Refer to section 5)
4. Remove the fan. (Refer to section 5)
5. Remove the 4 or 2 screws which fasten the motor. (See Fig. 10)
6. Remove the motor.
7. Re-install the components by referring to the removal procedure, above.

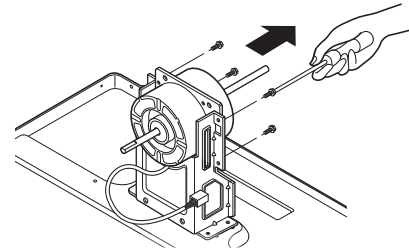

FIG. 10

COMPRESSOR

1. Remove the cabinet. (Refer to section 2)
2. Discharge the refrigerant system using Freon™ Recovery System.
If there is no valve to attach the recovery system, install one (such as a WATCO A-1) before venting the Freon™. Leave the valve in place after servicing the system.
3. Disconnect the 3 leads from the compressor.
4. After purging the unit completely, unbraid the suction and discharge tubes at the compressor connections.
5. Remove the 3 nuts and the 3 washers which fasten the compressor. (See Fig. 11)
6. Remove the compressor.
7. Re-install the components by referring to the removal procedure, above.

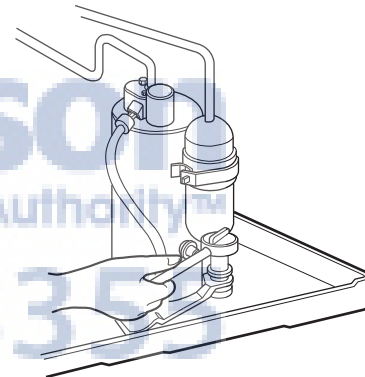

FIG. 11

CAPACITOR

1. Remove the control box. (Refer to section 3)
2. Remove a screw which fasten the display panel.
3. Remove 2 screws and unfold the control box. (See Fig. 12)
4. Remove the screw and the clamp which fastens the capacitor. (See Fig. 12)
5. Disconnect all the leads of capacitor terminals.
6. Re-install the components by referring to the removal procedure, above.

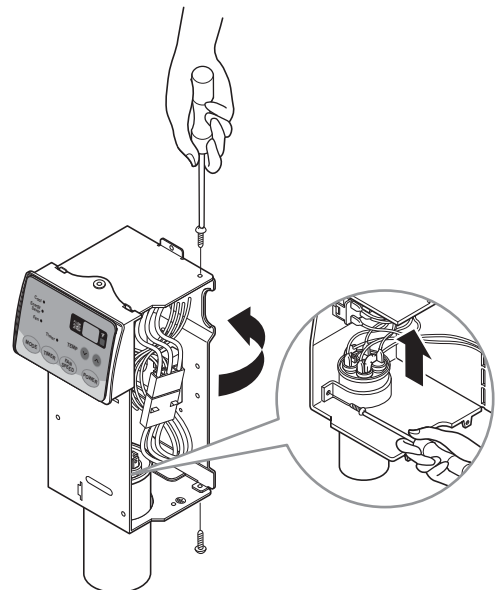

FIG. 12

1 □ POWER CORD

1. Remove the control box. (Refer to section 3)
2. Unfold the control box. (Refer to section 9)
3. Disconnect the grounding screw from the control box.
4. Disconnect 2 receptacles.
5. Remove a screw which fastens the clip cord.
6. Pull the power cord. (See Fig. 13)
7. Re-install the component by referring to the removal procedure, above.
(Use only one ground-marked hole \oplus for ground connection.)
8. If the supply cord of this appliance is damaged, it must be replaced by the special cord.
(The special cord means the cord which has the same specification marked on the supply cord fitted to the unit.)

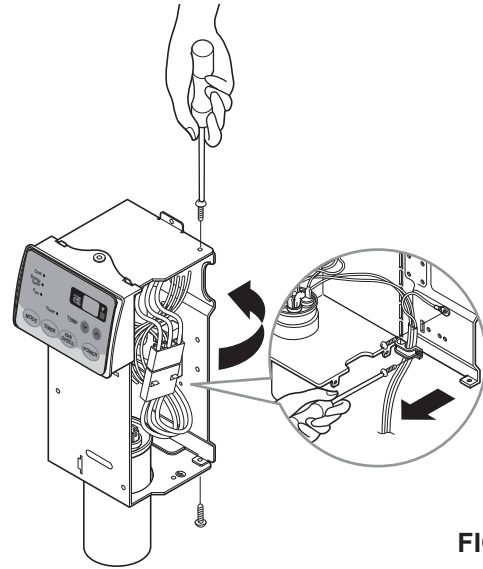

FIG. 1 □

11. THERMOSTAT

1. Remove the control box. (Refer to section 3)
2. Unfold the control box. (Refer to section 9)
3. Disconnect the thermostat terminals from main P.W.B assembly.
4. Remove the thermostat. (See Fig. 14)
5. Re-install the components by referring to the removal procedure, above.

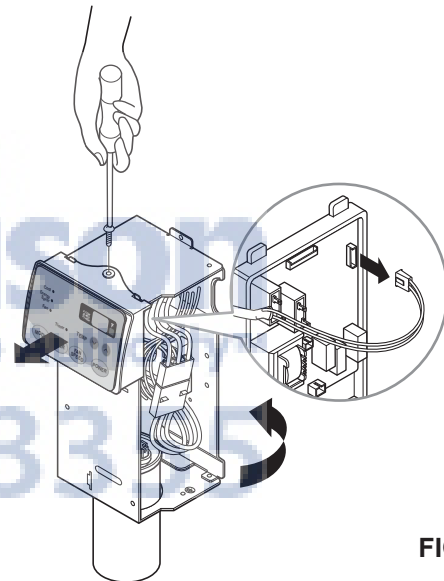

FIG. 1 □

Refrigerating Cycle

CAUTION

Discharge the refrigerant system using Freon™ Recovery System.
If there is no valve to attach the recovery system, install one (such as a WATCO A-1) before venting the Freon™. Leave the valve in place after servicing the system.

12. CONDENSER

1. Remove the cabinet. (Refer to section 2)
2. Remove the brace and the shroud cover. (Refer to section 4)
3. Remove the 5 screws which fasten the condenser.
4. After discharging the refrigerant completely, unbrazed the interconnecting tube at the condenser connections.
5. Remove the condenser.
6. Re-install the components by referring to notes. (See Fig. 15)

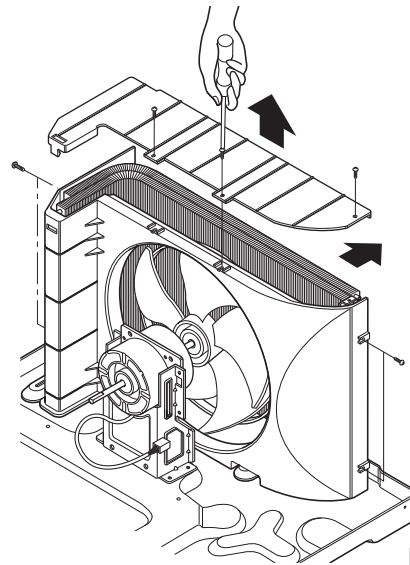

FIG. 1

1. EVAPORATOR

1. Remove the cabinet. (Refer to section 2)
2. Discharge the refrigerant completely.
3. Remove the 2 screws which fasten the evaporator at the left side and the right side.
4. Move the evaporator sideward carefully and then unbrazed the interconnecting tube at the evaporator connectors.
5. Remove the evaporator.
6. Re-install the components by referring to notes. (See Fig. 16)

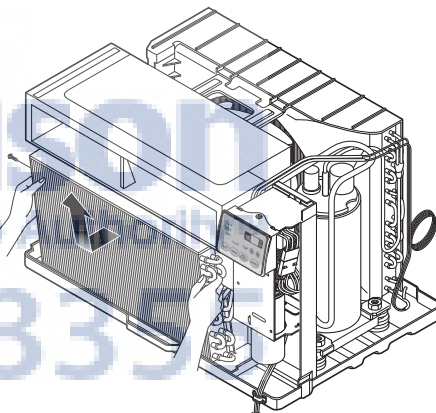

FIG. 1

1. CAPILLARY TUBE

1. Remove the cabinet. (Refer to section 2)
2. After discharging the refrigerant completely, unbrazed the interconnecting tube at the capillary tube.
3. Remove the capillary tube.
4. Re-install the components by referring to notes.

NOTICE

— Replacement of the refrigeration cycle.

1. When replacing the refrigeration cycle, be sure to discharge the refrigerant system using a Freon™ recovery System.
If there is no valve to attach the recovery system, install one (such as a WATCO A-1) before venting the Freon™. Leave the valve in place after servicing the system.
2. After discharging the unit completely, remove the desired component, and unbrace the pinch-off tubes.
3. Solder service valves into the pinch-off tube ports, leaving the valves open.
4. Solder the pinch-off tubes with Service valves.
5. Evacuate as follows.
 - 1) Connect the vacuum pump, as illustrated Fig. 17A.
 - 2) Start the vacuum pump, slowly open manifold valves A and B with two full turns counterclockwise and leave the valves closed.
The vacuum pump is now pulling through valves A and B up to valve C by means of the manifold and entire system.

CAUTION

If high vacuum equipment is used, just crack valves A and B for a few minutes, then open slowly with the two full turns counterclockwise. This will keep oil from foaming and being drawn into the vacuum pump.

- 3) Operate the vacuum pump for 20 to 30 minutes, until 600 microns of vacuum is obtained. Close valves A and B, and observe vacuum gauge for a few minutes. A rise in pressure would indicate a possible leak or moisture remaining in the system. With valves A and B closed, stop the vacuum pump.
- 4) Remove the hose from the vacuum pump and place it on the charging cylinder. See Fig. 17B. Open valve C.
Discharge the line at the manifold connection.
- 5) The system is now ready for final charging.

6. Recharge as follows :

- 1) Refrigeration cycle systems are charged from the High-side. If the total charge cannot be put in the High-side, the balance will be put in the suction line through the access valve which you installed as the system was opened.
- 2) Connect the charging cylinder as shown in Fig. 17B. With valve C open, discharge the hose at the manifold connection.
- 3) Open valve A and allow the proper charge to enter the system. Valve B is still closed.
- 4) If more charge is required, the high-side will not take it. Close valve A.
- 5) With the unit running, open valve B and add the balance of the charge.
 - a. Do not add the liquid refrigerant to the Low-side.
 - b. Watch the Low-side gauge; allow pressure to rise to 39 lbs.
 - c. Turn off valve B and allow pressure to drop.
 - d. Repeat steps B and C until the balance of the charge is in the system.
- 6) When satisfied the unit is operating correctly, use the pinch-off tool with the unit still running and clamp on to the pinch-off tube. Using a tube cutter, cut the pinch-off tube about 2 inches from the pinch-off tool. Use sil-fos solder and solder pinch-off tube closed. Turn off the unit, allow it to set for a while, and then test the leakage of the pinch-off connection.

Equipment needed □ Vacuum pump, Charging cylinder, Manifold gauge, Brazing equipment. Pinch-off tool capable of making a vapor-proof seal, Leak detector, Tubing cutter, Hand Tools to remove components, Service valve.

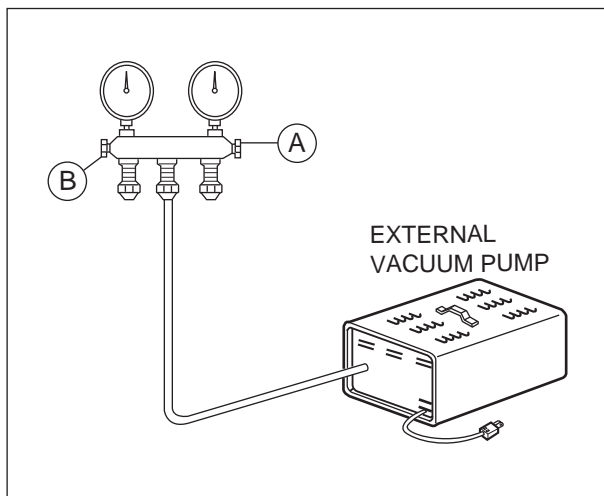
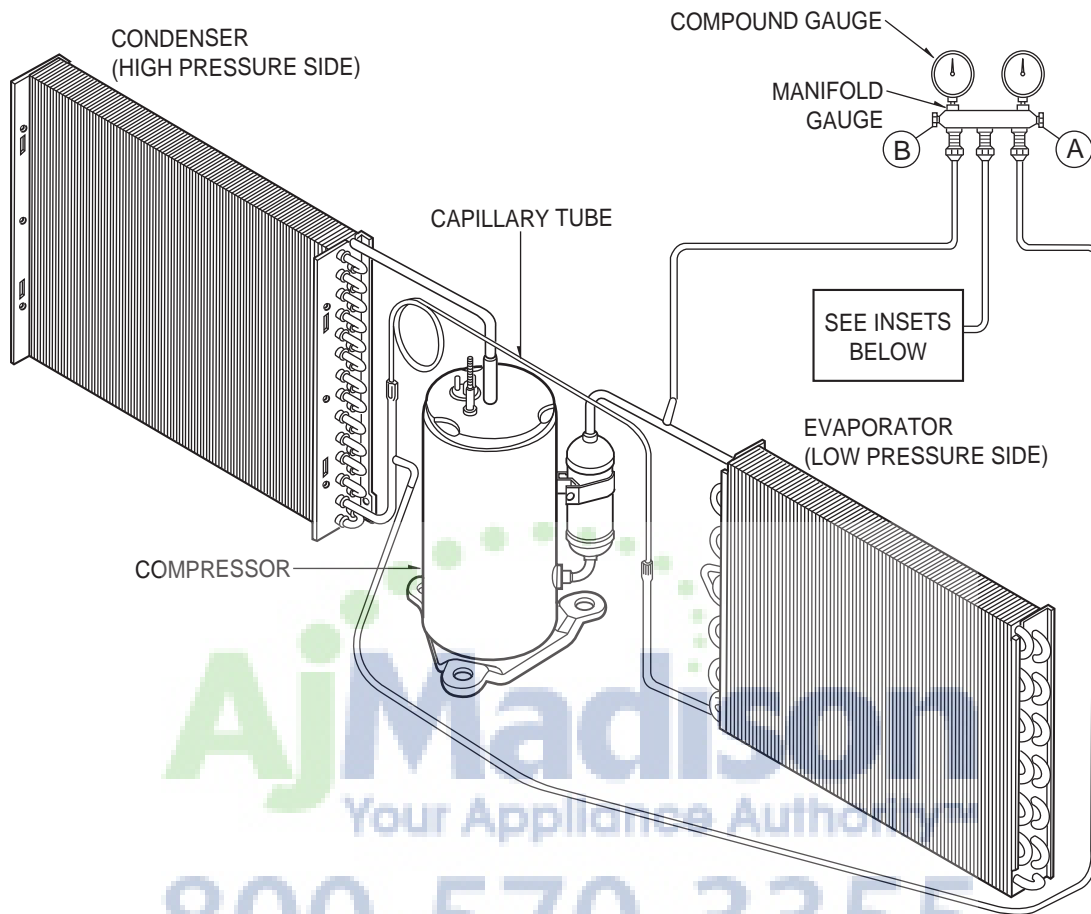

FIG. 1 □A-Pulling □vacuum

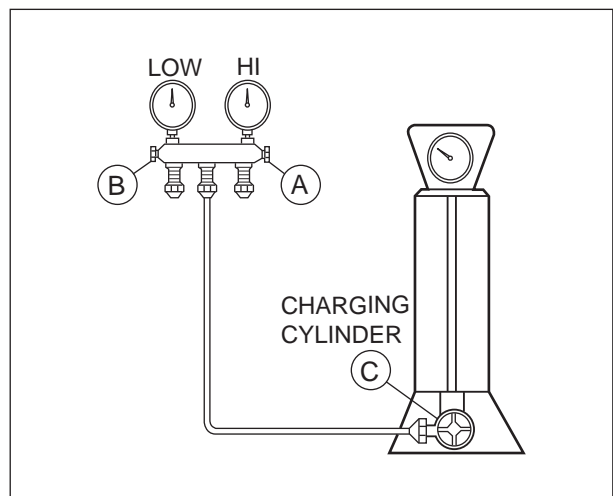
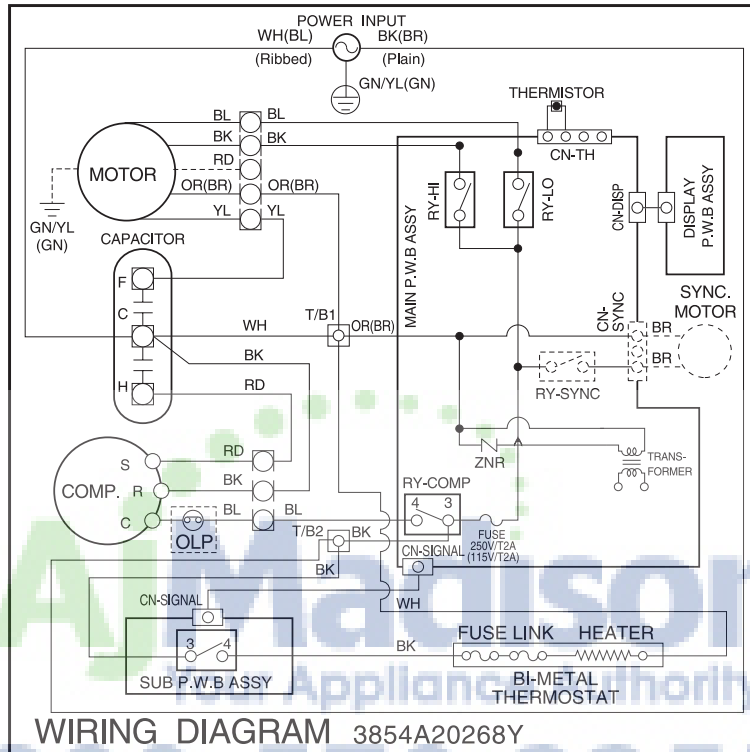

FIG 1 □B-Charging

Schematic Diagram

Wiring Diagram

■ ELECTRIC HEATING MODEL



Troubleshooting Guide

Piping System

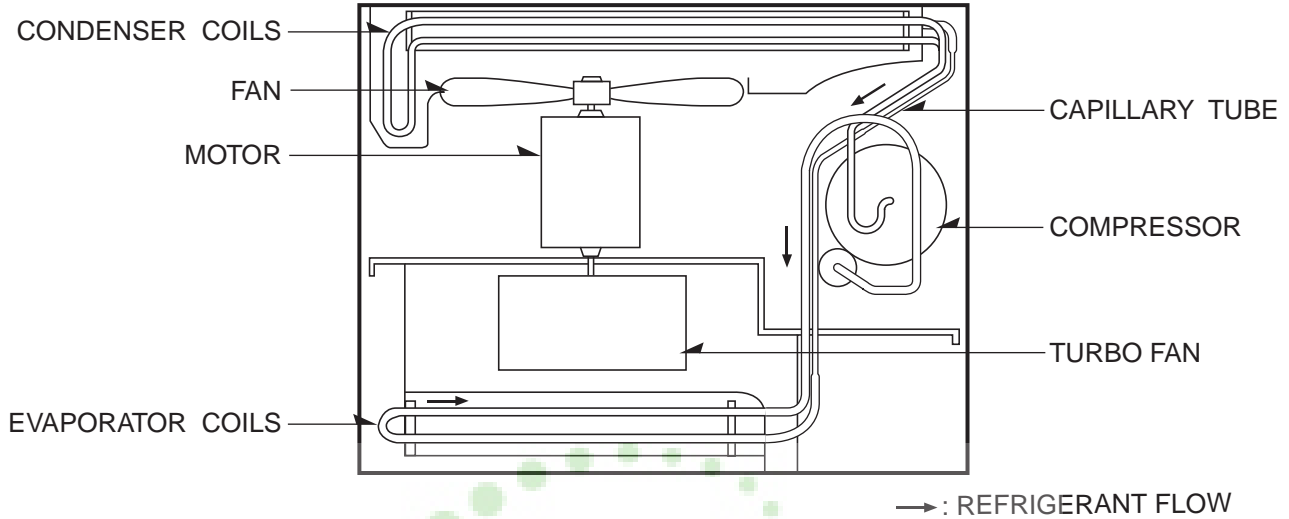

Following is a brief description of the important components and their functions in the refrigeration system. Refer to Fig. 18 to follow the refrigeration cycle and the flow of the refrigerant in the cooling cycle.

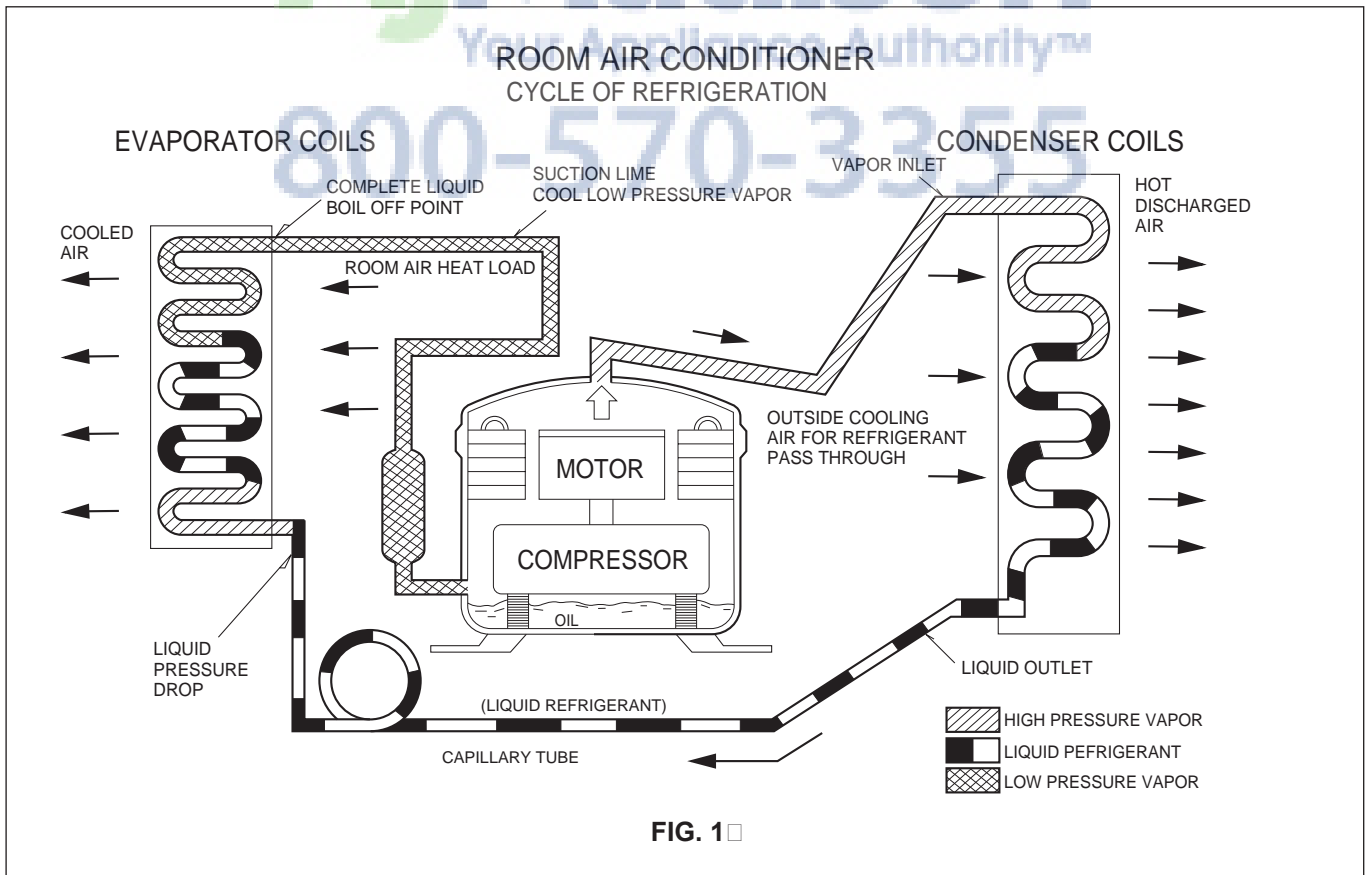

Troubleshooting Guide

In general, possible trouble is classified in two causes.

The one is called Starting Failure which is caused from an electrical defect, and the other is Ineffective Air Conditioning caused by a defect in the refrigeration circuit and improper application.

Unit is running but cooling is ineffective

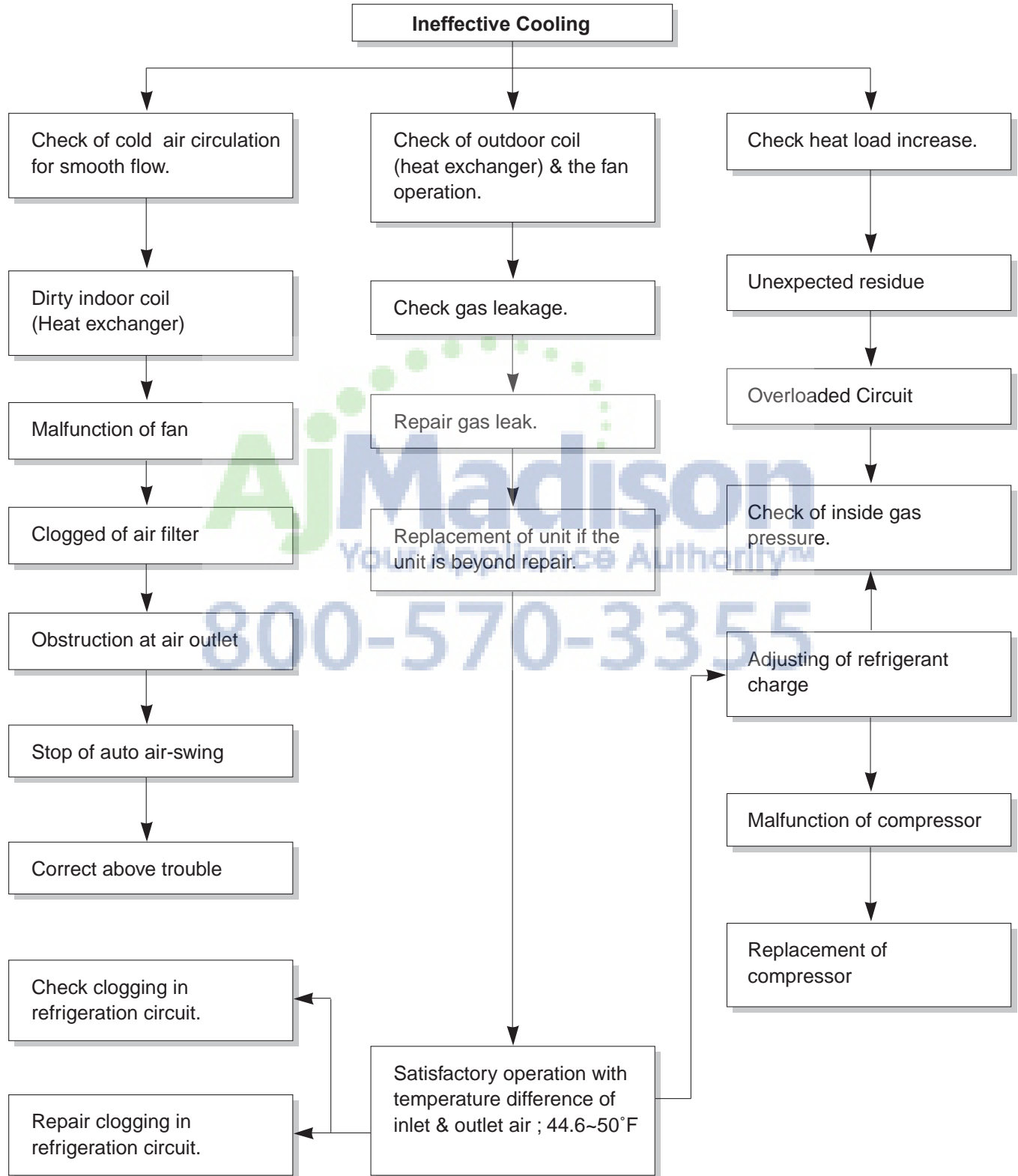

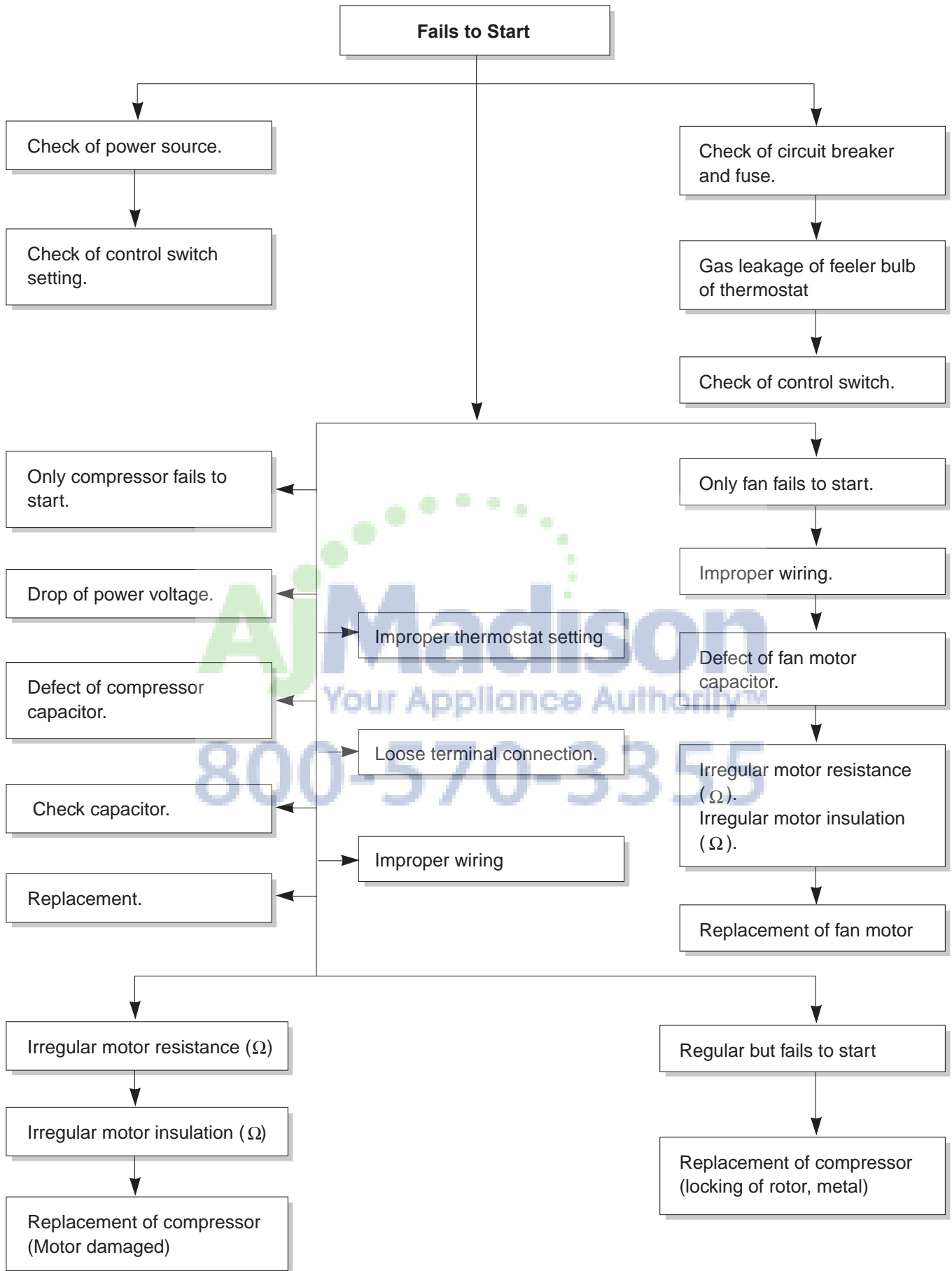

COMPLAINT	CAUSE	REMEDY
Fan motor will not run.	No power	Check voltage at outlet. Correct if none.
	Wire disconnected or connection loose	Connect wire. Refer to wiring diagram for terminal identification. Repair or replace loose terminal.
	Capacitor (Discharge capacitor before testing.)	Test capacitor. Replace if not within $\pm 10\%$ of manufacturer's rating. Replace if shorted, open, or damaged.
	Will not rotate	Fan blade hitting shroud or blower wheel hitting scroll. Realign assembly. Units using slinger ring condenser fans must have $\frac{1}{4}$ to $\frac{5}{16}$ inch clearance to the base. If it is hitting the base, shim up the bottom of the fan motor with mounting screw(s). Check fan motor bearings; if motor shaft will not rotate, replace the motor.
Fan motor runs intermittently	Revolves on overload.	Check voltage. See limits on this page. If not within limits, call an electrician. Test capacitor. Check bearings. Does the fan blade rotate freely? If not, replace fan motor. Pay attention to any change from high speed to low speed. If the speed does not change, replace the motor.
Fan motor noise.	Grommets	Check grommets; if worn or missing, replace them.
	Fan	If cracked, out of balance, or partially missing, replace it.
	Turbo fan	If cracked, out of balance, or partially missing, replace it.
	Loose set screw	Tighten it.
	Worn bearings	If knocking sounds continue when running or loose, replace the motor. If the motor hums or noise appears to be internal while running, replace motor.

COMPLAINT	CAUSE	REMEDY
Compressor will not run, but fan motor runs.	Voltage	Check voltage. See the limits on the preceding page. If not within limits, call an electrician.
	Wiring	Check the wire connections, if loose, repair or replace the terminal. If wires are off, refer to wiring diagram for identification, and replace. Check wire locations. If not per wiring diagram, correct.
	Capacitor (Discharge capacitor before servicing.)	Check the capacitor. Replace if not within $\pm 10\%$ of manufacturers rating. Replace if shorted, open, or damaged.
	Compressor	Check the compressor for open circuit or ground. If open or grounded, replace the compressor.
	Overload	Check the compressor overload, if externally mounted. Replace if open. (If the compressor temperature is high, remove the overload, cool it, and retest.)

AjMadison
Your Appliance Authority
800-570-3355

ROOM AIR CONDITIONER VOLTAGE LIMITS

NAME PLATE RATING	MINIMUM	MAXIMUM
115V	103.5V	126.5V
208/230V	187V	253V

COMPLAINT	CAUSE	REMEDY
Compressor cycles on overload.	Voltage	Check the voltage. See the limits on the preceding page. If not within limits, call an electrician.
	Overload	Check overload, if externally mounted. Replace if open. (If the compressor temperature is high, remove the overload, cool, and retest.)
	Fan motor	If not running, determine the cause. Replace if required.
	Condenser air flow restriction	Remove the cabinet. inspect the interior surface of the condenser; if restricted, clean carefully with a vacuum cleaner (do not damage fins) or brush. Clean the interior base before reassembling.
	Condenser fins (damaged)	If condenser fins are closed over a large area on the coil surface, head pressures will increase, causing the compressor to cycle. Straighten the fins or replace the coil.
	Capacitor	Test capacitor.
	Wiring	Check the terminals. If loose, repair or replace.
	Refrigerating system	Check the system for a restriction.
Insufficient cooling or heating	Air filter	If restricted, clean or replace.
	Exhaust damper door	Close if open.
	Unit undersized	Determine if the unit is properly sized for the area to be cooled.
Excessive noise.	Blower or fan	Check the set screw or clamp. If loose or missing, correct. If the blower or fan is hitting air guide, rearrange the air handling parts.
	Copper tubing	Remove the cabinet and carefully rearrange tubing not to contact cabinet, compressor, shroud, and barrier.

ITEMS \ MODELS		REMARK	UE08C13	
COOLING		POWER SUPPLY	1Ø,115V,60HZ	
		CAPACITY(Btu/h)	8,000	
		INPUT(W)	830	
		RUNNING CURRENT(A)	7.5	
		E.E.R(Btu/W.h)	9.6	
HEATING		CAPACITY(Btu/h)	3,850	
		INPUT(W)	1,230	
		RUNNING CURRENT(A)	10.7	
OPERATING TEMPERATURE	COOLING	INDOOR(°F)	80 (DB) 67 (WB)	
		OUTDOOR(°F)	95 (DB) 75 (WB)	
	HEATING	INDOOR(°F)	70 (DB) 60 (WB)	
		OUTDOOR(°F)	47 (DB) 44 (WB)	
REFRIGERANT(R410A) CHARGE(g)			320 (11.3OZ)	
EVAPORATOR			2 ROW 12 STACKS	LOUVER-FIN TYPE
CONDENSER			Ø5.0 3 ROW 18 STACKS,L-BENDED TYPE	
FAN,INDOOR			TURBO FAN	
FAN,OUTDOOR			PROPELLER TYPE FAN WITH SLINGER-RING	
FAN,SPEEDS (FAN/COOLING/HEATING)			2/2/2	
FAN,MOTOR			6 POLES	
OPERATION CONTROL			TOUCH PANEL	
ROOM TEMP.CONTROL			THERMISTOR	
AIR DIRECTTION CONTROL			VERTICAL LOUVER (RIGHT&LEFT)	
			HORIZONTAL LOUVER (UP&DOWN)	
CONSTRUCTION			TOP - DOWN	
ELECTRIC HEATER			3.5KW,230V	
PROTECTOR	COMPRESSOR		EXTERNAL OVERLOAD PROTECTOR	
	FAN,MOTOR		INTERANL THERMAL PROTECTOR	
	ELECTRIC HEATER		FUSE LINK,BIMETAL THERMOSTAT	
POWER CORD			1.92m (3WIRE WITH GROUding)	
			ATTACHMENT PLUG(CORD-CONNECTED TYPE)	
DRAIN SYSTEM			SPLASHED BY FAN SLINGER	
NET WEIGHT(lbs/kg)			80/36	
DIMENSION (Wx Hx D)	(inch)		24 21/32 x 14 13/32 x 19 21/32	
	(mm)		656 x 366 x 499	
SLEEVE DIMESION (Wx Hx D)	(inch)		25 7/8 x 15 17/32 x 16 23/32	OPTIONA PART
	(mm)		656 x 394 x 425	
SLEEVE DEPTH	(inch)		20	
WITH FRONT GRILLE	(mm)		510	

ITEMS		MODELS	REMARK	UE10C33	
COOLING			POWER SUPPLY	1Ø,230/208V,60HZ	
			CAPACITY(Btu/h)	10,000/9,800	
			INPUT(W)	1,080/1,040	
			RUNNING CURRENT(A)	4.7/5.2	
			E.E.R(Btu/W.h)	9.4/9.4	
HEATING			CAPACITY(Btu/h)	11,200/9,200	
			INPUT(W)	3,500/2,900	
			RUNNING CURRENT(A)	15.3/14.0	
OPERATING TEMPERATURE	COOLING	INDOOR(°F)		80 (DB) 67 (WB)	
		OUTDOOR(°F)		95 (DB) 75 (WB)	
	HEATING	INDOOR(°F)		70 (DB) 60 (WB)	
		OUTDOOR(°F)		47 (DB) 44 (WB)	
REFRIGERANT(R410A) CHARGE(g)			440 (15.5OZ)		
EVAPORATOR			3 ROW 12 STACKS	LOUVER-FIN TYPE	
CONDENSER			2 ROW 18 STACKS,L-BENDED TYPE 1 ROW		
FAN,INDOOR			TURBO FAN		
FAN,OUTDOOR			PROPELLER TYPE FAN WITH SLINGER-RING		
FAN,SPEEDS (FAN/COOLING/HEATING)			2/2/2		
FAN,MOTOR			6 POLES		
OPERATION CONTROL			TOUCH PANEL		
ROOM TEMP.CONTROL			THERMISTOR		
AIR DIRECTTION CONTROL			VERTICAL LOUVER (RIGHT&LEFT)		
			HORIZONTAL LOUVER (UP&DOWN)		
CONSTRUCTION			TOP - DOWN		
ELECTRIC HEATER			3.5KW,230V		
PROTECTOR	COMPRESSOR		EXTERNAL OVERLOAD PROTECTOR		
	FAN,MOTOR		INTERANL THERMAL PROTECTOR		
	ELECTRIC HEATER		FUSE LINK,BIMETAL THERMOSTAT		
POWER CORD			1.92m (3WIRE WITH GROUDING) ATTACHMENT PLUG(CORD-CONNECTED TYPE)		
DRAIN SYSTEM			SPLASHED BY FAN SLINGER		
NET WEIGHT(lbs/kg)			80/36		
DIMENSION (Wx Hx D)	(inch)		24 21/32 x 14 13/32 x 19 21/32		
	(mm)		656 x 366 x 499		
SLEEVE DIMESION (Wx Hx D)	(inch)		25 7/8 x 15 17/32 x 16 23/32	OPTIONA PART	
	(mm)		656 x 394 x 425		
SLEEVE DEPTH	(inch)		20		
WITH FRONT GRILLE	(mm)		510		

ITEMS		MODELS	REMARK	UE12C13	
COOLING			POWER SUPPLY	1Ø,230/208V,60HZ	
			CAPACITY(Btu/h)	11,500/11,200	
			INPUT(W)	1,220/1,190	
			RUNNING CURRENT(A)	5.6/6.0	
			E.E.R(Btu/W.h)	9.4/9.4	
HEATING			CAPACITY(Btu/h)	11,200/9,200	
			INPUT(W)	3,500/2,900	
			RUNNING CURRENT(A)	15.3/14.0	
OPERATING TEMPERATURE	COOLING	INDOOR(°F)		80 (DB) 67 (WB)	
		OUTDOOR(°F)		95 (DB) 75 (WB)	
	HEATING	INDOOR(°F)		70 (DB) 60 (WB)	
		OUTDOOR(°F)		47 (DB) 44 (WB)	
REFRIGERANT(R410A) CHARGE(g)			540 (19.0OZ)		
EVAPORATOR			3 ROW 12 STACKS	LOUVER-FIN TYPE	
CONDENSER			2 ROW 18 STACKS,L-BENDED TYPE 1 ROW		
FAN,INDOOR			TURBO FAN		
FAN,OUTDOOR			PROPELLER TYPE FAN WITH SLINGER-RING		
FAN,SPEEDS (FAN/COOLING/HEATING)			2/2/2		
FAN,MOTOR			6 POLES		
OPERATION CONTROL			TOUCH PANEL		
ROOM TEMP.CONTROL			THERMISTOR		
AIR DIRECTION CONTROL			VERTICAL LOUVER (RIGHT&LEFT)		
			HORIZONTAL LOUVER (UP&DOWN)		
CONSTRUCTION			TOP - DOWN		
ELECTRIC HEATER			3.5KW,230V		
PROTECTOR	COMPRESSOR		EXTERNAL OVERLOAD PROTECTOR		
	FAN,MOTOR		INTERANL THERMAL PROTECTOR		
	ELECTRIC HEATER		FUSE LINK,BIMETAL THERMOSTAT		
POWER CORD			1.92m (3WIRE WITH GROUDING)		
			ATTACHMENT PLUG(CORD-CONNECTED TYPE)		
DRAIN SYSTEM			SPLASHED BY FAN SLINGER		
NET WEIGHT(lbs/kg)			80/36		
DIMENSION (Wx Hx D)	(inch)		24 21/32 x 14 13/32 x 19 21/32		
	(mm)		656 x 366 x 499		
SLEEVE DIMESION (Wx Hx D)	(inch)		25 7/8 x 15 17/32 x 16 23/32	OPTIONA PART	
	(mm)		656 x 394 x 425		
SLEEVE DEPTH	(inch)		20		
WITH FRONT GRILLE	(mm)		510		

Exploded View

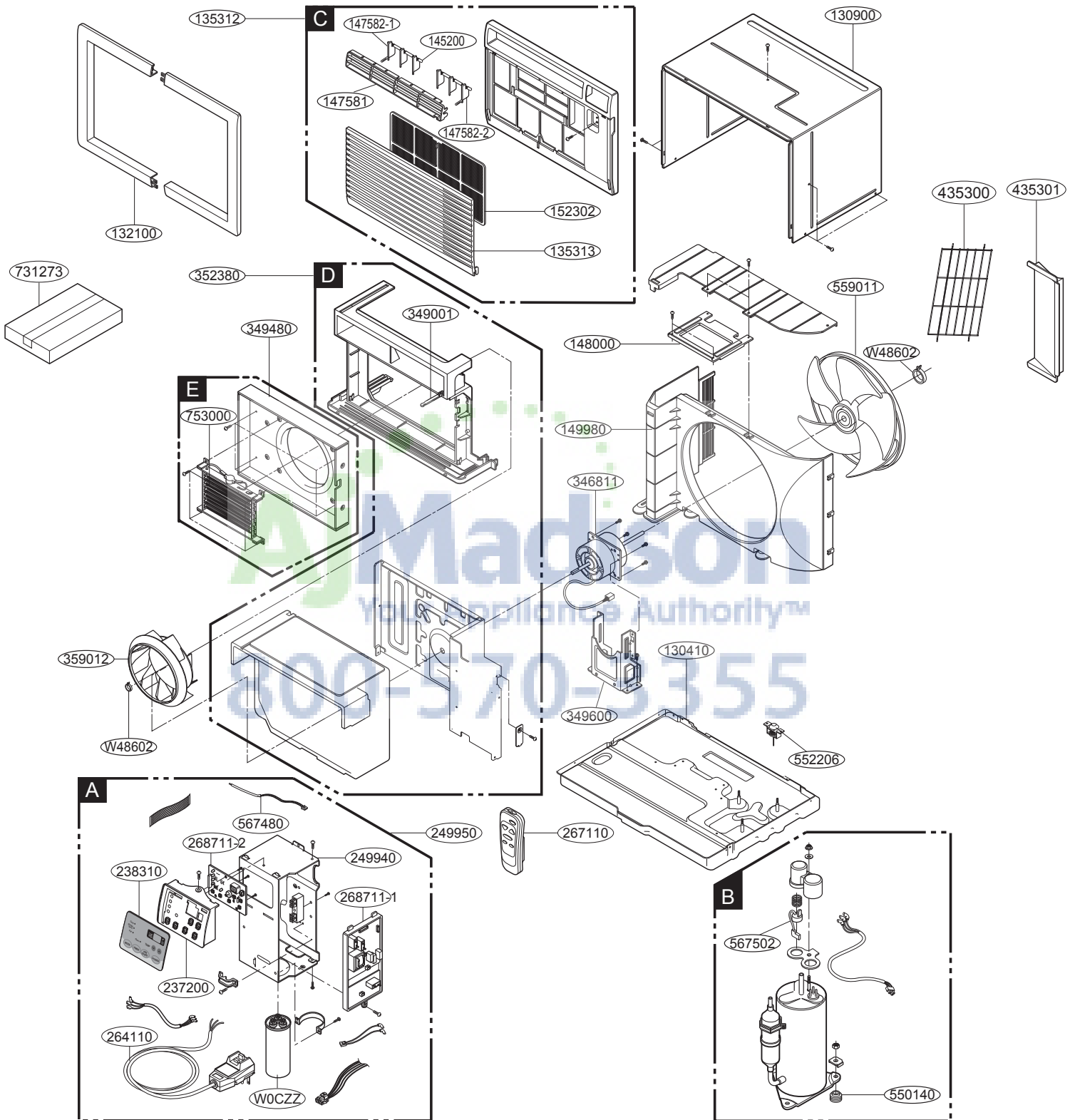

LocNo	Description	UE08C13
W0CZZ	CAPACITOR,FILM,BOX	67301909
130410	BASE ASSEMBLY,SINGLE	67302923
130900	CABINET	67303718
132100	FRAME	67303504
135303	GRILLE,INLET	67306113
135312	GRILLE ASSEMBLY,FRONT(SINGLE)	67306020
238310	ESCUTCHEON	67304802
W48602	CLAMP,SPRING	67302500
346811	MOTOR ASSEMBLY,SINGLE	67303019
147581	LOUVER,HORIZONTAL	67306203
147582-1	LOUVER,VERTICAL	67306252
147582-2	LOUVER,VERTICAL	67306253
349600	BRACKET,MOTOR	67303607
149980	SHROUD	67303111
550140	DAMPER,COMPRESSOR	67305000
152302	FILTER,AIR	67304304
352380	AIR GUIDE	67302735
359012	FAN,TURBO	67302608
559011	FAN ASSEMBLY,AXIAL	67303202
567480	THERMISTOR ASSEMBLY	67307808
264110	POWER CORD ASSEMBLY	67300031
267110	REMOTE CONTROLLER ASSEMBLY	67302239
567502	OverloadProtect	67301907
268711-2	PWB(PCB) ASSEMBLY,MAIN	67307644
268711-1	PWB(PCB) ASSEMBLY,DISPLAY	67307646
435300	PLASTIC REAR AIR DEFLECTOR	67307208
237200	PANEL,CONTROL	67305527
731273	INSTALL PART ASSEMBLY,SINGLE	67306307
249950	CASE ASSEMBLY,CONTROL	67305528
435301	GRILLE,REAR	67304801
349480	ORIFICE	67303406
753000	Heater,Electric	67310101

LocNo	Description	UE10C33
W0CZZ	CAPACITOR,FILM,BOX	67301910
130410	BASE ASSEMBLY,SINGLE	67302923
130900	CABINET	67303718
132100	FRAME	67303504
135303	GRILLE,INLET	67306104
135312	GRILLE ASSEMBLY,FRONT(SINGLE)	67306005
238310	ESCUTCHEON	67304802
W48602	CLAMP,SPRING	67302500
346811	MOTOR ASSEMBLY,SINGLE	67303008
147581	LOUVER,HORIZONTAL	67306203
147582-1	LOUVER,VERTICAL	67306252
147582-2	LOUVER,VERTICAL	67306253
349600	BRACKET,MOTOR	67303607
149980	SHROUD	67303111
550140	DAMPER,COMPRESSOR	67305000
152302	FILTER,AIR	67304304
352380	AIR GUIDE	67302735
359012	FAN,TURBO	67302608
559011	FAN ASSEMBLY,AXIAL	67303202
567480	THERMISTOR ASSEMBLY	67307808
264110	POWER CORD ASSEMBLY	67300029
267110	REMOTE CONTROLLER ASSEMBLY	67302239
567502	OverloadProtect	67301908
268711-2	PWB(PCB) ASSEMBLY,MAIN	67307645
268711-1	PWB(PCB) ASSEMBLY,DISPLAY	67307646
435300	PLASTIC REAR AIR DEFLECTOR	67307208
237200	PANEL,CONTROL	67305527
731273	INSTALL PART ASSEMBLY,SINGLE	67306307
249950	CASE ASSEMBLY,CONTROL	67305529
435301	GRILLE,REAR	67304801
349480	ORIFICE	67303406
753000	Heater,Electric	67310100

LocNo	Description	UE12C33
W0CZZ	CAPACITOR,FILM,BOX	67301911
130410	BASE ASSEMBLY,SINGLE	67302930
130900	CABINET	67303718
132100	FRAME	67303504
135303	GRILLE,INLET	67306104
135312	GRILLE ASSEMBLY,FRONT(SINGLE)	67306005
238310	ESCUTCHEON	67304802
W48602	CLAMP,SPRING	67302500
346811	MOTOR ASSEMBLY,SINGLE	67303020
147581	LOUVER,HORIZONTAL	67306203
147582-1	LOUVER,VERTICAL	67306252
147582-2	LOUVER,VERTICAL	67306253
349600	BRACKET,MOTOR	67303606
149980	SHROUD	67303111
550140	DAMPER,COMPRESSOR	67305000
152302	FILTER,AIR	67304304
352380	AIR GUIDE	67302735
359012	FAN,TURBO	67302608
559011	FAN ASSEMBLY,AXIAL	67303202
567480	THERMISTOR ASSEMBLY	67307808
264110	POWER CORD ASSEMBLY	67300029
267110	REMOTE CONTROLLER ASSEMBLY	67302239
567502	OverloadProtect	67301906
268711-2	PWB(PCB) ASSEMBLY,MAIN	67307645
268711-1	PWB(PCB) ASSEMBLY,DISPLAY	67307646
435300	PLASTIC REAR AIR DEFLECTOR	67307208
237200	PANEL,CONTROL	67305527
731273	INSTALL PART ASSEMBLY,SINGLE	67306307
249950	CASE ASSEMBLY,CONTROL	67305530
435301	GRILLE,REAR	67304801
349480	ORIFICE	67303406
753000	Heater,Electric	67310100



F R I E D R I C H

FRIEDRICH AIR CONDITIONING CO.

Visit our web site at www.friedrich.com

Post Office Box 1540 • 4200 N. Pan Am Expressway • San Antonio, Texas 78295-1540
• (210) 357-4400 • FAX (210) 357-4480

P 00000 0000 USA

U 00000000 C 000 S 00 P 0000 0000 000000