

# URRE315 - 15" REFRIGERATOR

## THE HOME COLLECTION

# U-LINE



### DESIGN

**Black interiors with stainless steel accents.**

**Classic bar door pull** on stainless steel models.

Concealed, zero-clearance **articulating door hinge**.

**Panel-ready integrated doors**, customizable with your panel and hardware, or **choose from our accessory options**.

### FEATURES

Built for both **indoor & outdoor use**, with condensation mitigation system.

**Carbon filter** for enhanced air quality and odor reduction.

**Center cabinet vertical lighting**: Complete illumination for full visibility throughout the entire interior.

**Door alarm** activates when the door is left open.

**Effortless entry door**: Minimizes the physical effort needed, enhancing ease of use for all family members.

**Electronic touch control** enables precise temperature selection from **34°F to 70°F**.

**Evenly distributed forced-air refrigeration system** delivers rapid cool down and temperature stability.

**Field reversible door** is shipped right-hand hinged.

**Four leveling legs** adjustable up to 1 inch.

**Low-E coated, argon gas filled, double thermopane glass door** provides protection from harmful UV light.

**Low-profile variable speed compressor** ensures efficient and powerful cooling with a max output of 1,850 BTU/h.

**Sabbath Mode** disables interior lights, alarms, and digital displays while maintaining consistent cooling performance.

**Six-color multi-point LED lighting** in adjustable white: bright white, warm white, cool white, and light blue, deep blue, and teal.

### STORAGE

**2.8 cu. ft. capacity** stores up to **72 12-oz cans**.

**Cantilever adjustment points** for complete interior adaptability.

**Three glass shelves**.

### CAPACITY

Volume	2.8 cu. ft.
Cans (12 oz)	72

### DIMENSIONS

Product Depth	22 11/16" (57.6 cm)
Product Height (Min.)	34 1/8" (86.7 cm)
Product Width	14 7/8" (37.8 cm)
Product Weight	105 lbs
Shipping Depth	31" (78.7 cm)
Shipping Height	37" (94 cm)
Shipping Width	19" (48.3 cm)
Shipping Weight	125 lbs

### CUSTOM PANEL DIMENSIONS

Panel Height	30" (76.2 cm)
Panel Thickness	3/4" (1.9 cm)
Panel Width	14 15/16" (37.9 cm)
Panel Weight (Max.)	20 lbs
Panel Type	2 3/4" (7 cm) frame or solid panel

### SUSTAINABILITY

Refrigerant Type	R600a
GWP (Global Warming Potential)	3 (very low)
ENERGY STAR	Yes

### TECHNICAL DETAILS

Cord Length	6 ft.
Electrical Requirements	115V / 60 Hz / 15A

### WARRANTY

2 year parts & labor warranty / 6 year sealed system parts warranty (see complete warranty for details).



# URRE315 - 15" REFRIGERATOR

## THE HOME COLLECTION

# U-LINE

### INSTALLATION

No additional clearance is needed for ventilation.

Do not obstruct front grille air flow.

Requires 3/4" custom panel and handle (not supplied by U-Line).

### PRODUCT DIMENSIONS

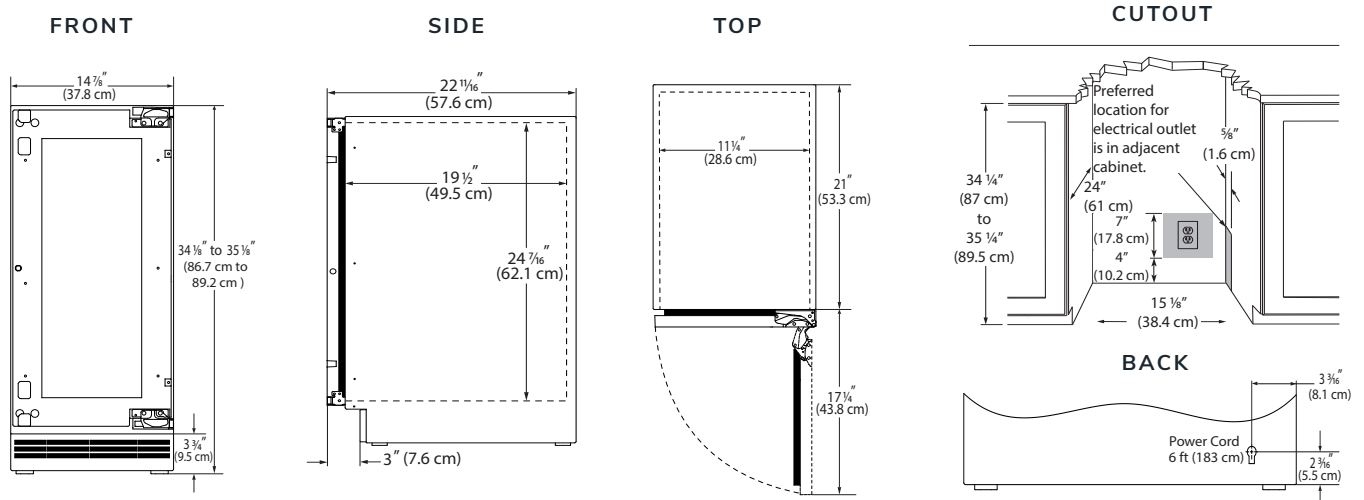

### MODELS



**URRE315-IG01A**  
Integrated Frame Glass



**URRE315-IS01A**  
Integrated Solid



**URRE315-SG01A**  
Stainless Steel Frame Glass



**URRE315-SS01A**  
Stainless Steel Solid

### ACCESSORIES



**ULASBPGLOSS15 (Frame)**  
**ULASBPSOLID15 (Solid)**  
 Stainless Steel Door Wrap  
 with Classic Bar Pull