

ADDITIONAL PRODUCT DIMENSIONS

Side View

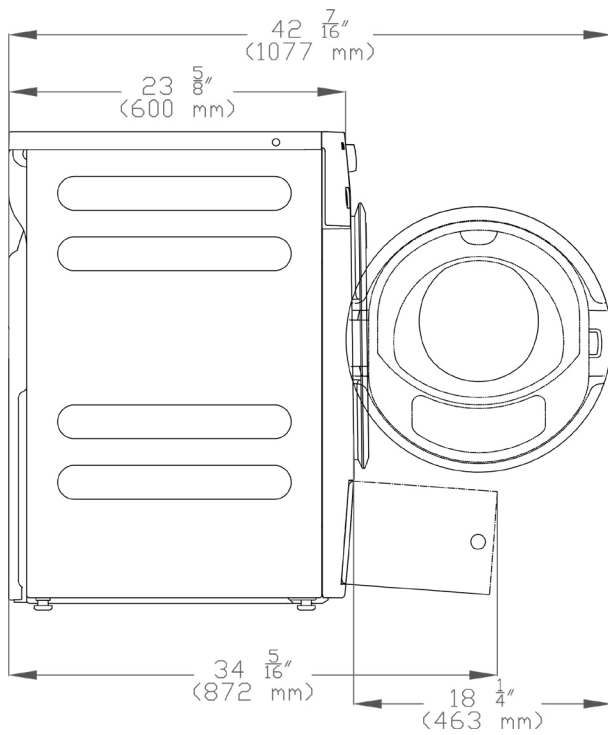

Rear View

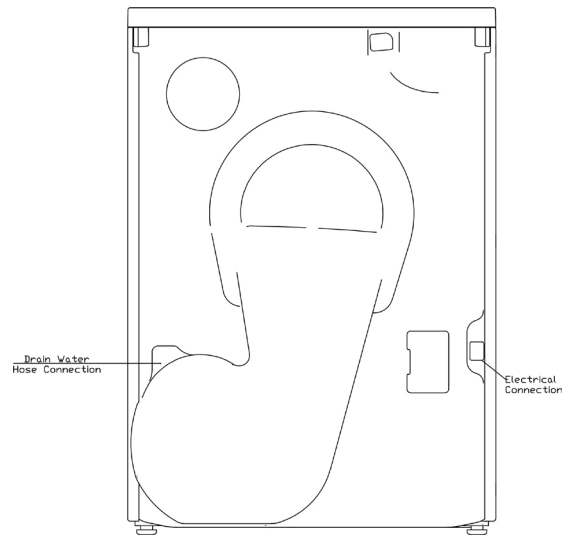

NICHE DIMENSIONS

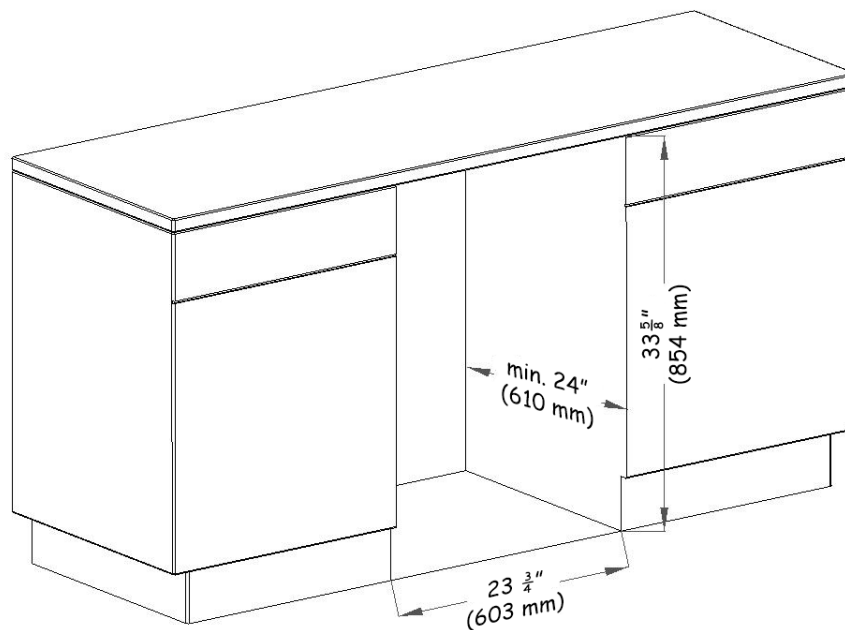

OPTIONAL ACCESSORIES

WTV502

Material# 9256140

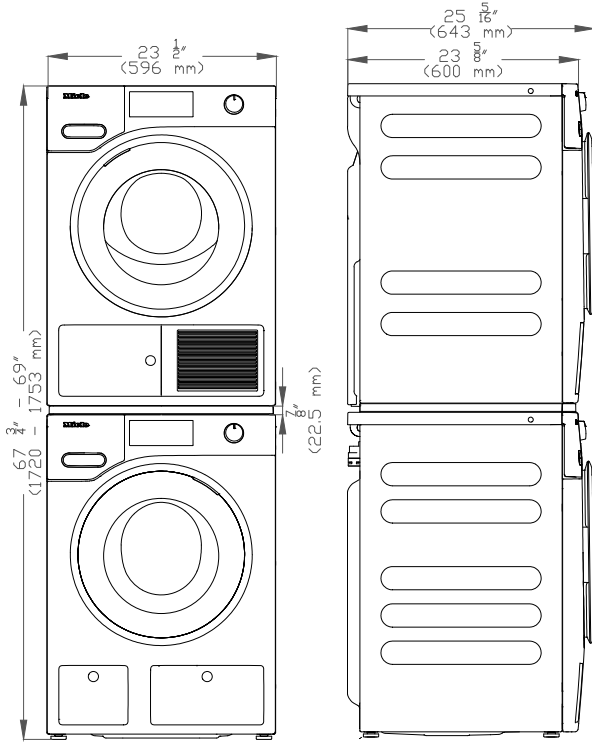

WTV512

Material# 9351790

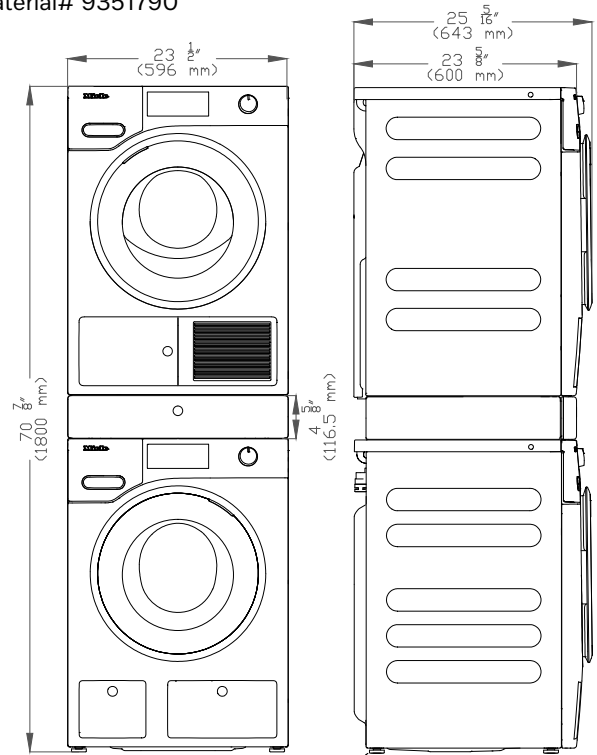

WTS610

Material# 12349900

