

PURCHASER	P.O. #	DATE
PROJECT	LOCATION	
ENGINEER	ARCHITECT	
SUBMITTED BY	FOR APPROVAL	FOR REFERENCE

ITEM	PLAN DESIGNATION	QUANTITY	COOLING BTU/H	VOLTAGE	FRIEDRICH MODEL

Comfort & convenience

- Rotary compressors provide quiet, dependable performance
- Six-way air flow control
- Stale air exhaust
- Auto restart
- Washable/reusable filter
- Seacoast protection



Digital control features

- 12 hour programmable timer
- Money Saver® setting saves money by conserving energy





Sleeve Dimension	Friedrich USC Sleeve	Amana	Carrier [51S Series]	Fedders/ Emerson/ Friedrich WSD	Emerson/ Fedders	GE/Hot-point	Whirl-pool	White-West-inghouse/Frigi-daire/ Carrier [52F Series]
Height (inches)	15 17/32	15 5/8	16 7/8	16 3/4	15 3/4	15 5/8	16 1/2	15 1/4
Width (inches)	25 7/8	26	25 3/4	27	26 3/4	26	25 7/8	25 1/2
Depth (inches)	16 23/32	16 7/8	18 5/8	16 3/4 or 19 3/4	15	16 7/8	17 1/8 or 23	16, 17 1/2 or 22

Specifications

★ ENERGY STAR® qualified

Model	Cooling Capacity Btu	Heating Capacity Btu	Volts Rated	Cooling Amps	Cooling Watts	Heating Amps	Heating Watts	Energy Efficiency Ratio EER	Moisture Removal Pints/HR	Room Side Air Circulation CFM	Sleeve	Net Weight Lbs
UNI-FIT												
<i>Cool Only</i>												
★ US08C10	8000	-	115	7.5	830	-	-	9.6	2.2	260	USC	73
★ US10C10	9800	-	115	9.6	1040	-	-	9.4	3.2	285	USC	78
★ US12C10	11500	-	115	11.2	1220	-	-	9.4	3.8	290	USC	80
★ US10C30	10000/9800	-	230/208	4.7/5.2	1060/1040	-	-	9.4/9.4	3.2	285	USC	78
★ US12C30	11500/11200	-	230/208	5.6/6.0	1220/1190	-	-	9.4/9.4	3.8	290	USC	80
★ US14C30	13000/12600	-	230/208	7.0/7.5	1530/1480	-	-	9.4/9.4	4.0	310	USC	87
<i>Cool with Electric Heat</i>												
UE08C13	8000	3850	115	7.5	830	10.7	1230	9.6	2.2	260	USC	73
UE10C33	10000/9800	11200/9200	230/208	4.7/5.2	1060/1040	15.3/14.0	3500/2900	9.4/9.4	3.2	285	USC	78
UE12C33	11500/11200	11200/9200	230/208	5.6/6.0	1220/1190	15.3/14.0	3500/2900	9.4/9.4	3.8	290	USC	80

Plug Face/ Circuit Rating

Uni-Fit Model Number	Circuit Rating Breaker or T-D Fuse	Plug Face (NEMA#)	Power Cord Length (ft.)	Wall Outlet Appearance
US08C10, UE08C13 US10C10, US12C10	125V - 15A	5 - 15P	6	
US10C30, US12C30, US14C30	250V - 15A	6 - 15P	4	
UE10C33, UE12C33	250V - 20A	6 - 20P	4	

Power cords are located on front right of Uni-Fit models.

Sleeve/Chassis Dimensions

Model	Sleeve Dimensions			Chassis Dimensions			Thru-the-wall Finished Hole		
	Height	Width	Depth	Depth with Front	Minimum Extension Into Room	Minimum Extension Outside	Height	Width	Max. Depth
UNI-FIT									
USC Sleeve	15 1/2"	25 7/8"	16 3/4"	20 1/2"	-	1/2"	15 3/4"	26 1/8"	16 1/4"
US Chassis	14 3/8"	24"		20 1/8"	3 3/4"	-	-	-	-
UE Chassis	14 3/8"	24 5/8"		19 5/8"	3 1/2"	-	-	-	-

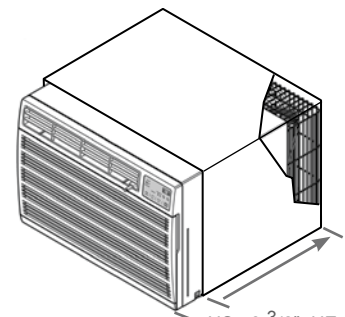

IMPORTANT:
US chassis w/front fully installed into USC sleeve extends into room 3 3/8". UE chassis w/front fully installed into USC sleeve extends into room 2 7/8".

As an ENERGY STAR® partner, Friedrich Air Conditioning Co. has determined that the selected ENERGY STAR® models (★) meet the ENERGY STAR® guidelines for energy efficiency.

