



INSTALLATION INSTRUCTIONS

PROFESSIONAL RANGE MODELS

60" DUAL FUEL, CONVECTION, SELF-CLEAN, SEALED BURNERS**

60" NATURAL GAS MODELS

*TN637-7BW

*TN637-7W

THIS MODEL IS NOT FIELD CONVERTIBLE FOR LP/PROPANE GAS. IT MUST BE ORDERED FROM THE FACTORY SET FOR NATURAL OR LP/PROPANE GAS.

60" LP/PROPANE GAS MODELS

*PN637-7BW

*PN637-7W

THIS MODEL IS NOT FIELD CONVERTIBLE FOR NATURAL GAS. IT MUST BE ORDERED FROM THE FACTORY SET FOR NATURAL OR LP/PROPANE GAS.



IF YOU HAVE QUESTIONS, CALL 800-251-7224, 8 AM TO 5 PM EASTERN TIME, OR VISIT OUR WEBSITE, WWW.FIVESTARRANGE.COM.

Installation Instructions



BEFORE YOU BEGIN

Read these instructions completely and carefully.

- **IMPORTANT** - Save these instructions for local inspector's use.
- **IMPORTANT** - Observe all governing codes and ordinances.
- **Note to Installer** - Be sure to leave these instructions with the Consumer.
- **Note to Consumer** - Keep these instructions for future reference.
- FiveStar recommends this product be installed by a licensed professional.
- Product failure due to improper installation is not covered under the Warranty.



WARNING:

This appliance must be properly grounded.

In the Commonwealth of Massachusetts:

- This product must be installed by a licensed plumber or gas fitter.
- When using ball type gas shut-off valves, they shall be T handle type.
- A flexible gas connector, when used, must not exceed Three (3) feet.



CAUTION:

THESE RANGES SHOULD BE INSTALLED IN CONJUNCTION WITH A SUITABLE OVERHEAD VENT HOOD. Due to the high heat capacity of this unit, particular attention should be paid to the hood duct work installation to assure it meets local building codes.

Standard countertop installations:

A 1200 CFM hood is recommended for 48" & 60" ranges.

A 600 CFM hood is recommended for 30" & 36" ranges.

Hoods should be 24" min. deep and at least the same width as the cooktop. FiveStar hoods may be installed from 24" to 30" above the cooking surface. A minimum of 28" is required when a FiveStar Backsplash with warming shelves is used.

Check local building codes for the proper method of gas range installation. Local codes vary. Installation, electrical connections and grounding must comply with applicable codes. In the absence of local codes, the gas range should be installed in accordance with the National Fuel Gas Code ANSI 223.1, latest edition and National Electrical Code ANSI/NFPA 70, latest edition.



CAUTION:

These ranges weigh up to 510 pounds. Some

disassembly will reduce the weight considerable. Due to the weight and size of the range and to reduce the risk of personal injury or damage to the produce and/or damage to the floor, TWO PEOPLE ARE REQUIRE FOR PROPER INSTALLATION.



INSTALLATION INSTRUCTIONS

**Please read these instructions
before attempting to install this
range**

Inspection and Unpacking

Check the range carton for visible damage. If there is damage or even creases in the carton, contact the carrier, request an inspection and file the appropriate freight claim. Do not refuse shipment. Responsibility for shipping damage is with the carrier or end user. Cut the shipping straps, then carefully lift the carton up from the range. This will help eliminate possible damage to the backguard that is packed in the top of the range carton.

Remove, unwrap and temporarily lay aside any parts that are not attached to the range. Make sure no parts are left in the carton for accidental disposal. **Carefully inspect the range for damage.**

STEP 1

REMOVE PACKAGING

Before moving the range indoors:

- Remove outer carton and packing material from the shipping base. The range is now ready for removal from the wooden base.

STEP 2

Due to the weight of these ranges, use a dolly with soft wheels to move this range.

- Lift the range onto the dolly and move indoors.
- The range should be placed onto sliders to prevent damage to the floor.

STEP 3

To simplify handling and to reduce the weight of the range:

- Remove the grates.
- Remove both reversible griddle/grill combos.
- Remove the broiler pans, racks and literature Package from inside oven(s).

STEP 4

LIFT OFF DOOR

To remove oven door(s):

- Open door fully.
- Rotate the "hinge retainers" into the locked position, as shown over the hook located on the bottom side of each hinge quadrant.
- Lift the door slightly, to clear "hinge slots", and pull straight out to clear hinge mechanism from main front opening.

Lift-Off Oven Door

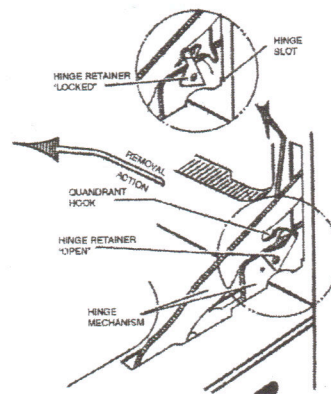

STEP 5

CONNECTING THE RANGE TO ELECTRIC

WARNING:

THIS APPLIANCE MUST BE CONNECTED AS SHOWN IN FIGURE 1 OR 2. IF A CORD IS UTILIZED IT MUST BE RATED AT 250 VOLTS, 40 AMPERES AND CERTIFIED FOR USE ON HOUSEHOLD RANGES.

WIRING RANGE CONNECTION CORD (FOR DUAL-FUEL RANGES ONLY)

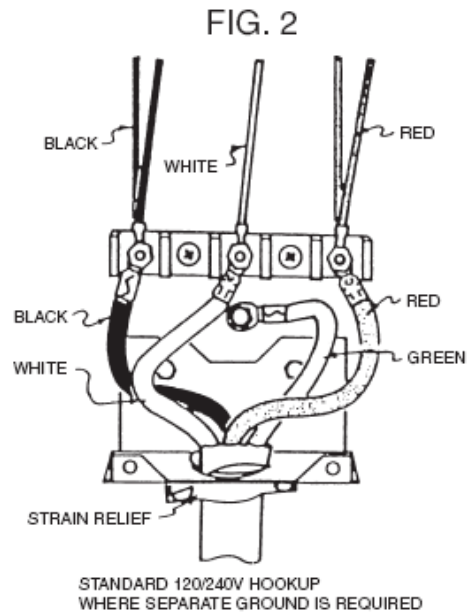
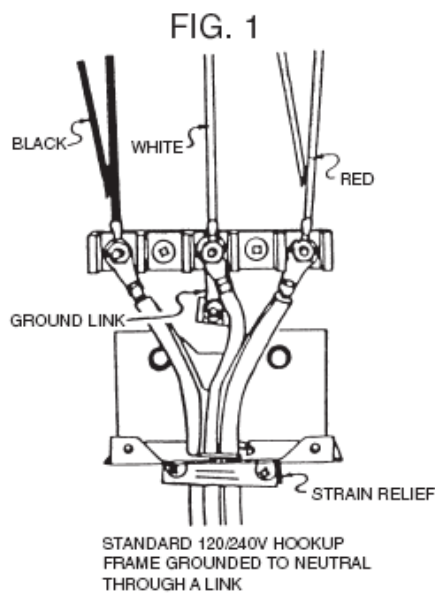

ELECTRICAL REQUIREMENTS FOR DUAL FUEL RANGES:

240 volts, 60 Hz, 35 amps

STEP 6

CONNECTING THE RANGE TO GAS

Because hard piping restricts movement of the range, the use of an A.G.A. certified flexible metal appliance connector is recommended unless local codes require a hard-piped connection.

Never use an old connector when installing a new range. If the hard piping method is used, you must carefully align the pipe; the range cannot be moved after the connection is made.

To prevent gas leaks, put pipe joint compound on, or wrap pipe thread with Teflon* tape all around male (external) pipe threads.

- 6-1. Install a manual gas shut-off valve in the gas line in an easily accessed location outside the range. Make sure everyone operating the range knows where and how to shut off the gas supply to the range.
- 6-2. Install male $\frac{1}{2}$ " flare union adapter to the $\frac{1}{2}$ " NPT internal thread at inlet of the regulator. Use a backup wrench on the regulator fitting to avoid damage.
- 6-3. Install male $\frac{1}{2}$ " or $\frac{3}{4}$ " flare union adapter to the NPT internal thread of the manual shut-off valve, taking care to back-up the shut-off valve to keep it from turning.
- 6-4. Connect flexible metal appliance connector to the adapter on the range. Position range to permit connection at the shut-off valve or vice versa.
- 6-5. When all connections have been made, make sure all range controls are in the off position and turn on the main gas supply valve. Use a liquid leak detector at all joints and connections to check for leaks in the system.

When using test pressures greater than $\frac{1}{2}$ psig to pressure test the gas supply system of the residence, disconnect the range and individual shut-off valve from the gas supply piping. When using test pressures of $\frac{1}{2}$ psig or less to test the gas supply system, simply isolate the range from the gas supply system by closing the individual shut-off valve.

*Teflon: Registered trademark of Dupont.

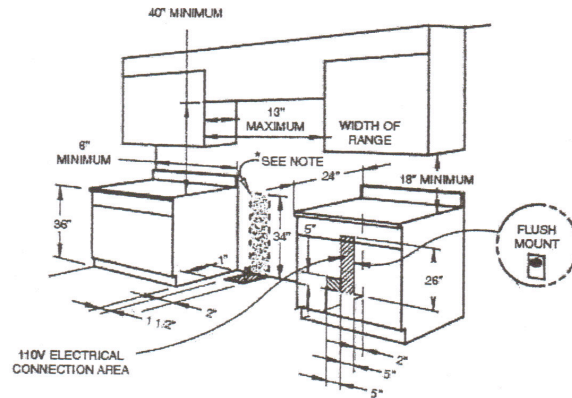

STEP 7

INSTALLING THE BACKGUARD – SEALED BURNER MODELS

NOTE: PLEASE READ ALL INSTRUCTIONS BEFORE STARTING INSTALLATION.

7-1

Remove the burner grates, griddle/grill and housing.

7-2

From the front of the range, remove the Phillip screws in the rear of each burner pan (black pan where the top burners are located).

7-3

From the rear of the range, remove two screws from the rear of the side panels, the upper most screw on each side. You will need a $\frac{5}{16}$ " nut-driver or $\frac{5}{16}$ " socket to remove these screws. (Tools with a magnetized tip will be helpful in replacing the backguard screws.)

7-4

From the rear of the range, locate the upper wire cover with tab slots. Remove two $\frac{5}{16}$ " mounting screws. This cover will be reinstalled once the backguard is installed.

7-5

Screws are installed in the backguard, at the Factory for assembly to the backguard support. It is important that you locate and remove these four screws from the backguard before you attempt to install the backguard to the range backguard support.

7-6

Remove the vinyl protective covering from the front of the backguard.

7-7

The front of the backguard should fit between the back burner pans and the rear support. If the burner pan and rear support have a tight tolerance, place a thin bladed screw driver at either end, between the burner pan and rear support, to start placement of the backguard. Slide the backguard over the exhaust vent(s). Align the slots in the front of the backguard with the rear support bar locator studs.

7-8

With the backguard in position, secure the backguard to the rear backguard support using the four $\frac{5}{16}$ " screws removed in step 7-4, re-install the screws in the edge of the side panels and replace the screws in the back of each burner pan. Re-install griddle/grill housing. Do not re-install the grates at this point.

7-9

Reinstall the upper wire cover that was removed in Step 7-4. Place the cover into position with the lower backguard panel fitting into the tab slots. Reinstall the two $\frac{5}{16}$ " mounting cover screws.

DIAGRAM FOR STEP 7

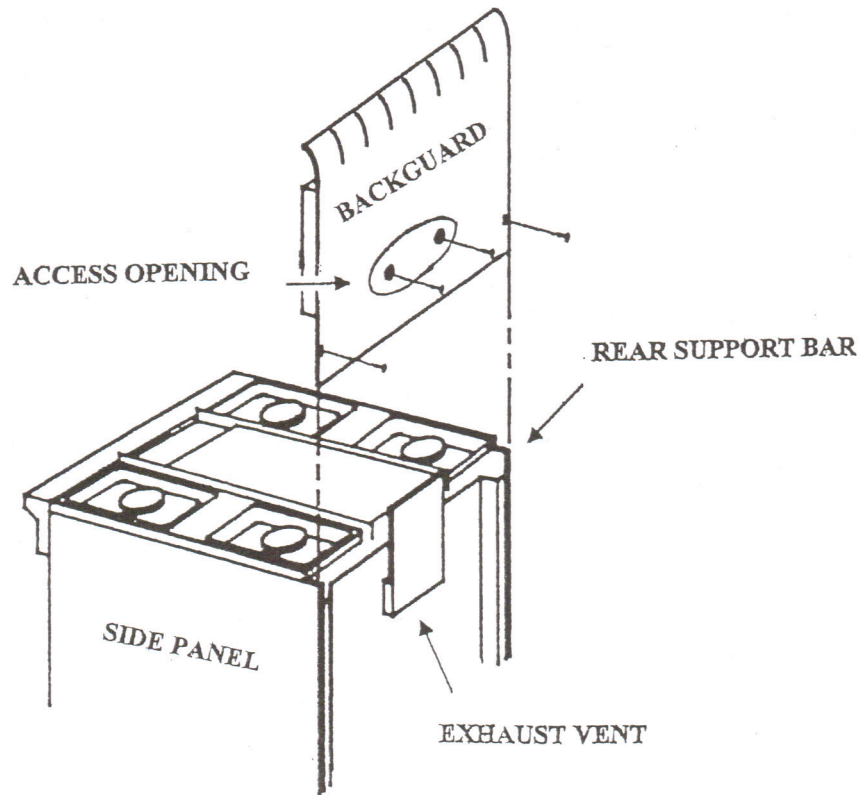

BACKGUARD INSTALLATION

STEP 8

LEVEL THE RANGE

1. Remove shipping tape from the leveling legs.
2. Carefully slide the range into position. **Be careful** not to damage the floor or entangle power cord and gas flexible tubing.
3. To adjust leveling legs, turn counter-clockwise to raise the range; clockwise to lower. "Channel-lock" type pliers are recommended. Avoid using a pipe wrench which can scar the legs.

IMPORTANT: The range should always be installed at countertop height or higher. **DO NOT INSTALL THE RANGE LOWER THAN ADJACENT COUNTERTOP HEIGHT, DUE TO RISK OF A FIRE HAZARD**

STEP 9

REPLACE THE OVEN DOORS

To replace the oven door(s);

- Insert hinges into front frame opening locating “hinge slots” on front frame as shown.
- Rotate “hinge retainers” back into the “open” position.
- Rotate door to make sure it functions properly.

CAUTION:

Take care when replacing the oven doors. If the hinge latch is not securely locked, the hinge may snap back and separate. If the hinge separates, you must apply pressure (possibly with your foot) to press it back together and then engage the hinge tech.

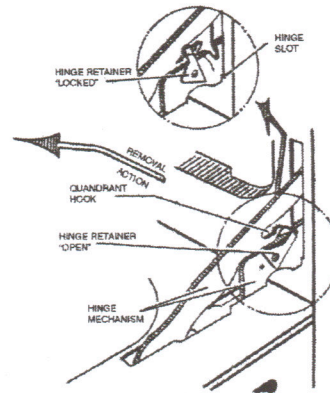

STEP 10

SURFACE BURNER OPERATION

SEALED BURNERS

Assemble top burners as shown. Check to be sure that burner heads and caps are securely seated. Burner cap must completely engage into burner base to ensure proper assembly.

- Check for proper ignition:
 - Push in one control knob and turn 45° counter clockwise to LITE position.
 - The igniter will spark and the burner will light; the igniter will cease sparking when the burner is lit.
 - First test may require some time, while air is flushed out of the gas line.
 - Turn knob to OFF.
 - Repeat the procedure for each burner.

IMPORTANT: If the ignitor electrodes continue to spark after the burners are lit, check that each burner component is assembled and seated properly. Disassemble and reassemble as required.

- Burner flames should be blue and stable with no yellow or yellow tips, excessive noise or lifting of the flame from the burner. If any of these conditions exist, check that the burner ports are not blocked. If one of these conditions continues, call for service. **Reminder:** This product must be operated with the fuel that it was produced for at the factory.

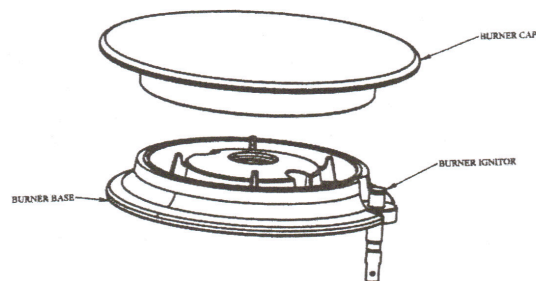

STEP 11

OVEN OPERATION

GAS OVEN

- Turn oven thermostat knob counter clockwise to 350°.
- The oven burner should light within 60 seconds.

ELECTRIC OVEN

- Turn oven thermostat knob counter clockwise to 350° in bake position. It will take a couple of minutes before a change in color will occur to the lower element.
- Turn oven thermostat knob to broil position. It will take a couple of minutes before a change in color will occur to the upper element.

GRIDDLE OPERATION

- Turn griddle thermostat knob counter clockwise to 350°.
- The griddle burner should light within 60 seconds.

STEP 12

GAS & ELECTRIC SUPPLY

- Turn gas supply "on".
- Turn electric supply "on".

STEP 13

CHECKLIST FOR SEALED BURNER INSTALLATION

- MAKE SURE ALL CONTROLS ARE IN THE “OFF” POSITION.**
- Gas supply is “on”
- Electric power is “on”
- Check for proper seating of burner caps into burner base
- Burner grates in position
- Oven and broiler racks installed
- Surface burner ignition test
- Griddle/Grill burner ignition test
- Griddle/Grill assembly in position
- Gas oven ignition test
- Electric oven – Check bake and broil function
- Check operation of convection fan
- MAKE SURE ALL CONTROLS ARE LEFT IN THE “OFF” POSITION.**

Date Installed & Inspected _____

Authorized Installer’s Signature _____

Please Print Name _____

- NOTE:** Please leave this checklist, Use & Care manual and product registration card with the Homeowner.