

SuperSteam+™ Oven

MODEL
SSC2489DS



SuperSteam+™
Oven: Model SSC2489DS

CUSTOMER ASSISTANCE (UNITED STATES ONLY).....	2	PRODUCT OVERVIEW	11-12
CUSTOMER ASSISTANCE (CANADA ONLY)	3	BEFORE FIRST USE	13-14
US CONSUMER LIMITED WARRANTY.....	4	CONNECTING TO YOUR APPLIANCE	15-16
CANADA CONSUMER LIMITED WARRANTY	5	COOKING OPERATION	17-21
IMPORTANT SAFETY INSTRUCTIONS.....	6-7	SETTING AND DEMO MODES	22
IMPORTANT REGULATORY INFORMATION	7	CLEANING.....	23-24
INFORMATION YOU NEED TO KNOW	8-10	BEFORE YOU CALL FOR SERVICE.....	25

REGISTER YOUR PRODUCT

Registering your new product is easy and offers benefits that help you get the most out of your Sharp product including:

- ✓ **Convenience:** If you ever need warranty support, your product information is already on file.
- ✓ **Communication:** Stay up to date with important notifications and special offers from SHARP.
- ✓ **Support:** Quickly access support content including Owner's Manuals, FAQ's, How-to Videos, and much more.

3 EASY WAYS TO REGISTER TODAY!

 <p>SCAN Use the camera or QR code scanning application on your mobile device</p> <p>Scan this QR Code on your mobile device</p>	 <p>ONLINE Visit our sites to learn more about your product at sharpusa.com and sbl.sharpusa.com</p> <p>Visit http://www.sharpusa.com/register</p>	 <p>CALL US US 800-BE-SHARP 800-237-4277 Mon-Fri: 7am-7pm CST Sat-Sun: 9am-7pm CST</p> <p>Contact a Sharp Advisor on the phone</p>
--	---	--

PRODUCT SUPPORT

If you have questions about the setup or operation of your product, please refer to the corresponding section within this manual.

Additionally, visit www.sharpusa.com/support to access exclusive content about your product including:

- FAQ's and How-To Videos
- Find or Request Service
- Purchase an Extended Warranty
- Downloads including the Installation Guide, Spec Sheet, and Owner's Manual

CONTACT US

If at any time you have questions or comments concerning your SHARP product, please contact the SHARP Customer Assistance Center. We are available to assist you through multiple contact methods for your convenience:

 <p>EMAIL Available 24/7 US: sharpusa.com</p> <p>See the Contact Us section on our sites</p>	 <p>CHAT ONLINE Mon-Fri: 7am-7pm CST Sat-Sun: 9am-7pm CST</p> <p>U.S. www.sharpusa.com/support</p>	 <p>CALL US US 800-BE-SHARP 800-237-4277 Mon-Fri: 7am-7pm CST Sat-Sun: 9am-7pm CST</p> <p>Contact a Sharp Advisor on the phone</p>
--	--	--

To aid in answering questions if you call for service or for reporting loss or theft, please use the space below to record the model and serial number located on the back side of the unit.

Model Number: _____

Serial Number: _____

Date of Purchase: _____

Dealer Name: _____

Address: _____

City: _____

Province: _____

Postal Code: _____

Telephone: _____

PRODUCT SUPPORT

If you have questions about the setup or operation of your product, please refer to the corresponding section within this manual.

Additionally, visit <http://sharp.ca/support-home.aspx> to access exclusive content about your product including:

- Find a Dealer
- Find Service Locations
- Downloads including the Installation Guide, Spec Sheet, and Owner's Manual

CONTACT US

If at any time you have questions or comments concerning your SHARP product, please contact the SHARP Customer Assistance Center. We are available to assist you through multiple contact methods for your convenience:



EMAIL

Available 24/7

See the Contact Us section on our site.

<http://sharp.ca/contact-emailus.aspx>



SUPPORT SITE

Product Downloads, Service Locator, Where to Buy, Toner Recycling Program and more.

CA | sharp.ca/support-home.aspx



CALL US

CA 877-278-6709
Mon-Fri: 7am-7pm CST

Contact a Sharp Advisor on the phone



US CONSUMER LIMITED WARRANTY

SHARP ELECTRONICS CORPORATION (“Sharp”) warrants to the first consumer purchaser (“Purchaser”) that this SHARP brand product (“Product”), when shipped in its original container and sold or distributed in the United States by Sharp or an authorized Sharp dealer or reseller, will be free from defective workmanship and materials and agrees that it will, at its option, either repair the defect or replace the defective Product or part thereof with a new or remanufactured equivalent at no charge to the Purchaser for parts or labor for the period(s) set forth below.

This limited warranty does not apply to any appearance items of the Product nor to the additional excluded item(s) set forth below nor to any Product the exterior of which has been damaged or defaced, which has been subjected to misuse, abnormal service or handling, or which has been altered or modified in design or construction.

In order to enforce the rights under this limited warranty, the Purchaser should follow the steps set forth below and provide proof of purchase to the servicer.

The limited warranty described herein is in addition to whatever implied warranties may be granted to Purchasers by law. ALL IMPLIED WARRANTIES INCLUDING THE WARRANTIES OF MERCHANTABILITY AND FITNESS FOR USE ARE LIMITED TO THE PERIOD(S) FROM THE DATE OF PURCHASE SET FORTH BELOW. Some states do not allow limitations on how long an implied warranty lasts, so the above limitation may not apply to you.

Neither the sales personnel of the seller nor any other person is authorized to make any warranties other than those described herein, or to extend the duration of any warranties beyond the time period described above on behalf of Sharp.

The warranties described herein shall be the sole and exclusive warranties granted by Sharp and shall be the sole and exclusive remedy available to the Purchaser. Correction of defects, in the manner and for the period of time described herein, shall constitute complete fulfillment of all liabilities and responsibilities of Sharp to the Purchaser with respect to the Product and shall constitute full satisfaction of all claims, whether based on contract, negligence, strict liability or otherwise. In no event shall Sharp be liable, or in any way responsible, for any damages or defects in the Product which were caused by repairs or attempted repairs performed by anyone other than an authorized servicer. Nor shall Sharp be liable or in any way responsible for any incident or consequential economic or property damage. Some states do not allow the exclusion of incidental or consequential damages, so the above exclusion may not apply to you.

THIS LIMITED WARRANTY GIVES YOU SPECIFIC LEGAL RIGHTS. YOU MAY ALSO HAVE OTHER RIGHTS WHICH VARY FROM STATE TO STATE.

THIS LIMITED WARRANTY IS VALID ONLY IN THE FIFTY (50) UNITED STATES, THE DISTRICT OF COLUMBIA AND PUERTO RICO.

Your product model number & description: Model # SSC2489DS or Home Use SuperSteam+ Oven. (Be sure to have this information available when you need service for your Product.)

Warranty period for this product: One (1) year parts and labor including in-home service.

Additional item(s) excluded from warranty coverage (if any): Non-functional accessories and light bulbs.

Where to obtain service: From a Sharp Authorized Servicer located in the United States. To find the location of the nearest Sharp Authorized Servicer, call Sharp toll free at 1-800-BE-SHARP (1-800-237-4277).

What to do to obtain service: In-home service is provided for one year from date of purchase. In-home service can be arranged by calling 1-800-BE-SHARP. Be sure to have Proof of Purchase available.

TO OBTAIN SUPPLY, ACCESSORY OR PRODUCT INFORMATION, CALL 1-800-BE-SHARP or visit www.sharpsusa.com. SAVE THE PROOF OF PURCHASE AS IT IS NEEDED SHOULD YOUR OVEN EVER REQUIRE WARRANTY SERVICE.



CANADA CONSUMER LIMITED WARRANTY
Congratulations on your purchase!

Sharp Electronics of Canada Ltd. (“Sharp”) warrants to the first purchaser for this Sharp brand product (“Product”), when shipped in its original container and sold or distributed in Canada by Sharp or by an authorized Sharp dealer, and Product was not sold “as is” or “sales final” that the Product will during the applicable warranty period, be free from defects in material and workmanship, and will within the applicable warranty period, either repair the defective Product or provide the first purchaser a replacement of the defective Product.

This warranty does not apply to any appearance items of the product nor to the additional excluded item(s) set forth below nor to any product the exterior of which has been damaged or defaced, which has been subjected to improper voltage or other misuse, abnormal service or handling, which has been altered or modified in design or construction, or if the serial number or model number affixed to Product has been removed, defaced, changed, altered or tampered with.

How to get service: Should this Sharp product fail to operate during the warranty period, warranty service is provided by an Authorized Sharp Service Centre or an Authorized Sharp Servicing Dealer. In home warranty service will be carried out to locations accessible by on-road service vehicle and within 50 km of an authorized Sharp service centre. The servicer may if necessary take the unit for repair at the servicer's facility. No other person (including any Sharp dealer or service centre) is authorized to extend, enlarge or transfer this warranty on behalf of Sharp.

The express warranties in this limited warranty are, except for consumer purchasers domiciled in Quebec, in lieu of and, except to the extent prohibited by applicable law, Sharp disclaims all other warranties and conditions, express or implied, whether arising by law, statute, by course of dealing or usage of trade, including, without limitation, implied warranties or conditions of merchantability and/or quality, fitness for a particular use or purpose, and/or non-infringement. Limitations (not applicable to consumer purchasers domiciled in Quebec to the extent prohibited under Quebec law): (a) Sharp shall not be liable for any incidental, special, consequential, economic, exemplary or indirect damages of any kind or nature (including lost profits or damages for loss of time or loss of use or loss of data) arising from or in any connection with the use or performance of a Product or a failure of a Product, even if Sharp is aware of or has been advised of the possibility of such damages; (b) the remedies described in this limited warranty constitute complete fulfillment of all obligations and responsibilities of Sharp to the purchaser with respect to the Product and shall constitute full satisfaction of all claims, whether based on contract, negligence, strict liability or otherwise. Some provinces may not allow the exclusion or limitation of certain damages, or limits on the duration or voiding of implied warranties or conditions; in such provinces, the exclusions and limits herein may not apply. This limited warranty is, except for consumer purchasers domiciled in Quebec, governed by the laws of the Province in Canada in which the purchaser has purchased the Product. For consumer purchasers domiciled in Quebec this limited warranty is governed by the laws of Quebec.

- Your product model number & description:** Model # SSC2489DS Home Use SuperSteam+ Oven. (Be sure to have this information available when you need service for your product.)
- Warranty period for this product:** One (1) year parts and labor including in-home service.
- Additional item(s) excluded from warranty coverage (if any):** Non-functional accessories, reservoir, drip tray, base tray, rack, baking tray, perforated tray and light bulb.

To obtain the name and address of the nearest Authorized Sharp Service Centre or Dealer, please contact:

SHARP ELECTRONICS OF CANADA LTD
335 Britannia Road East
Mississauga, Ontario
L4Z 1W9
(905) 568-7140
Website: www.sharp.ca

THIS LIMITED WARRANTY IS VALID ONLY IN CANADA

IMPORTANT SAFETY INSTRUCTIONS

READ ALL INSTRUCTIONS BEFORE USING

When using the appliance, basic safety precautions should be followed, including the items stated in this section.

WARNING *To reduce the risk of burns, electric shock, fire or injury to persons:*

- 1 Read all instructions before using the appliance.
- 2 Be sure your appliance is properly installed and grounded by a qualified technician in accordance with the provided Installation Manual. Have installer note which fuse/circuit supplies power to the oven in the fuse/circuit breaker panel.
- 3 Never use your appliance for warming or heating the room.
- 4 Children should not be left alone or unattended in area where appliance is in use. They should never be allowed to sit or stand on any part of the appliance.
- 5 Wear proper apparel. Loose-fitting or hanging garments (necklaces, sleeves, scarves or ties) should never be worn while using the appliance. Secure long hair so that it does not risk contact with the oven.
- 6 Do not repair or replace any part of the appliance unless specifically recommended in the manual. All other servicing should be referred to a qualified technician.
- 7 Flammable materials should not be stored in an oven or near surface units.
- 8 **DO NOT USE WATER ON GREASE FIRES!** Smother fire or flame or use dry chemical or foam-type extinguisher.
- 9 Use only dry potholders. Moist or damp potholders on hot surfaces may result in burns from steam. Do not use a towel or other bulky cloth.
- 10 Use care when opening door. Let hot air or steam escape before removing or replacing food.
- 11 Do not heat unopened food containers. Buildup of pressure may cause container to burst and result in injury.
- 12 Keep oven vent ducts and all other openings on the appliance unobstructed.
- 13 Always place oven racks in desired location while oven is cool. If rack must be moved while oven is hot, use caution in order to prevent burns.
- 14 Use this appliance only for its intended use as described in this manual. Do not use corrosive chemicals or vapors in this appliance. This appliance is specifically designed to heat, cook or dry food. It is not designed for industrial or laboratory use.
- 15 Do not operate this appliance if it has a damaged cord or plug, if it is not working properly or if it has been damaged or dropped.
- 16 Do not store or use this appliance outdoors. Do not use this product near water—for example, near a kitchen sink, in a wet basement, near a swimming pool or similar locations.
- 17 Do not immerse cord or plug in water.
- 18 Keep cord away from heated surfaces.
- 19 Do not climb or sit on the appliance.
- 20 Keep fingers and other objects and materials away from the door of the appliance when closing.
- 21 When cleaning appliance, use only mild, nonabrasive soaps or detergents applied with a sponge or soft cloth. See cleaning instructions on pages 23-24.
- 22 To reduce the risk of fire in the appliance cavity:
 - a Do not overcook food. Carefully attend appliance when paper, plastic or other combustible materials are placed inside the appliance to facilitate cooking.
 - b Do not use the appliance for storage purposes. Do not leave paper products, cooking utensils or food in the appliance when not in use.
 - c Foods containing a large amount of high alcohol content can run the risk of igniting the steam in the oven cavity during cooking as the alcohol evaporates into the steam. Do not use the oven to prepare foods with a large amount of high alcohol content. Use caution when opening door after cooking.
- 23 If the appliance light fails, consult a SHARP AUTHORIZED SERVICER.

WARNING As a safety precaution, the oven will periodically exhaust steam during use in various cooking modes to reduce the amount of steam buildup in the cavity. The steam will exhaust from the air vent above the door, as pictured.

CAUTION Stand clear and do not block vent during steam exhaustion. Steam will be hot.

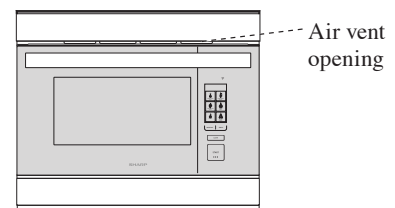

SAVE THESE INSTRUCTIONS

IMPORTANT SAFETY INSTRUCTIONS

CAUTION FOR WIRELESS LAN

CAUTION FOR USAGE ABOUT WI-FI

- If you are using in the following areas, the operation cannot be guaranteed: near Bluetooth® wireless communications devices using the same frequency (2.4 GHz) as this product or specified low power wireless devices. There may also be issues in locations with devices, such as microwave ovens, that emit a magnetic field; as well as in areas with static electricity or radio disturbance, all of which can interfere with the Wi-Fi signal.
- Wireless connection and performance cannot be guaranteed for all routers or housing environments. In the following places, it is possible the Wi-Fi cannot reach or is disconnected: inside of a building made with concrete, reinforced metal, near an obstruction (e.g., a wall) or near a wireless communications device using the same frequency.
- Wireless LAN of this product corresponds to channels 1-13. It is not available to communicate with routers set up to other channels.

CAUTION FOR PERSONAL INFORMATION (RELATED TO SECURITY)

- Using a wireless LAN device has the possibility of interception when using Wi-Fi, regardless of password setting.
- Depending on the location where you are connecting your oven, ensure you have the right/authority to connect the appliance to the available Wi-Fi network.
- If disposing of unit, giving or selling to a third party, be sure to Reset Wi-Fi Settings as described in this manual. The wireless LAN function of the unit should be initialized (reset) in case of handover to a third party to avoid illegal access from unauthorized parties.

MINIMUM REQUIREMENTS FOR WI-FI/ROUTER SPECIFICATIONS:

- IEEE 802.11 b/g/n compatible WLAN
- 72.2Mbps receive and transmit PHY rate using 20MHz bandwidth
- 150Mbps receive and transmit PHY rate using 40MHz bandwidth
- 802.11i (WPA, WPA2). Open, shared key, and pair-wise key authentication services
- Wi-Fi WPS support

IMPORTANT REGULATORY INFORMATION

CAUTION Any changes or modifications to the appliance not expressly approved by the party responsible for compliance could void the user's authority to operate the appliance.

NOTE: This equipment has been tested and found to comply with the limits for a Class B digital device, pursuant to Part 15 of the FCC Rules. These limits are designed to provide reasonable protection against harmful interference in a residential installation. This equipment generates, uses and can radiate radio frequency energy and, if not installed and used in accordance with the instructions, may cause harmful interference to radio communications. However, there is no guarantee that interference will not occur in a particular installation. If this equipment does cause harmful interference to radio or television reception, which can be determined by turning the equipment off and on, the user is encouraged to try to correct the interference by one or more of the following measures:

- Reorient or relocate the receiving antenna.
- Increase the separation between the equipment and receiver.
- Connect the equipment to an outlet on a circuit different from that to which the receiver is connected.
- Consult the dealer or an experienced radio/TV technician for help.

SHARP Home Use SuperSteam+ Oven Model # SSC2489DS

This device complies with Part 15 of the FCC Rules. Operation is subject to the following two conditions: (1) This device may not cause harmful interference, and (2) this device must accept any interference received, including interference that may cause undesired operation.

Responsible Party:

Sharp Electronics Corporation

100 Paragon Drive, Montvale, NJ 07645

TEL: 1-800-BE-SHARP (or www.sharppusa.com)

This device complies with Part 15 of the FCC Rules. Operation is subject to the following two conditions: (1) This device may not cause harmful interference, and (2) this device must accept any interference received, including interference that may cause undesired operation.

- Contains/Content FCC: RX3-B01
- Contains/Content IC: 2878F-B01

INFORMATION YOU NEED TO KNOW

ABOUT UNPACKING AND EXAMINING YOUR OVEN

- 1 Remove all packing materials from inside the oven.
- 2 Remove the feature sticker, if there is one. Check the oven for any damage, such as misaligned or bent oven, damaged oven seals and sealing surfaces, broken or loose door hinges and latches and dents inside the cavity or on the front side of the oven. If there is any damage, do not operate the oven. Contact your dealer or a SHARP AUTHORIZED SERVICER.
- 3 Install or locate this appliance only in accordance with the provided Installation Manual.

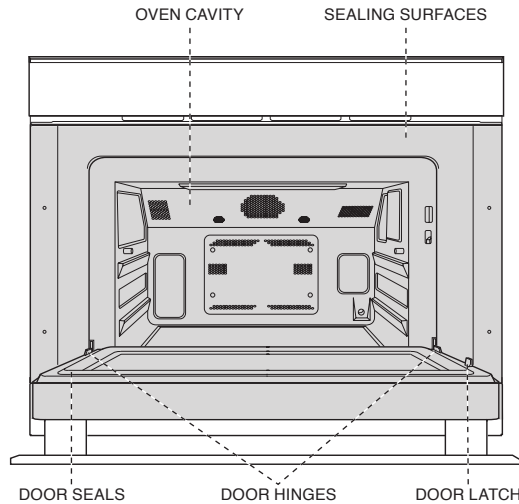

CHOOSING A LOCATION FOR YOUR OVEN

You will use your oven frequently, so plan its location for ease of use. Your oven can be built into a cabinet or wall by itself, or above any electric wall oven or above other Microwave Drawer models that specify the combination of this oven. The oven may be mounted below a 36" countertop, including a cooktop or island. It cannot be built in above any gas wall oven.

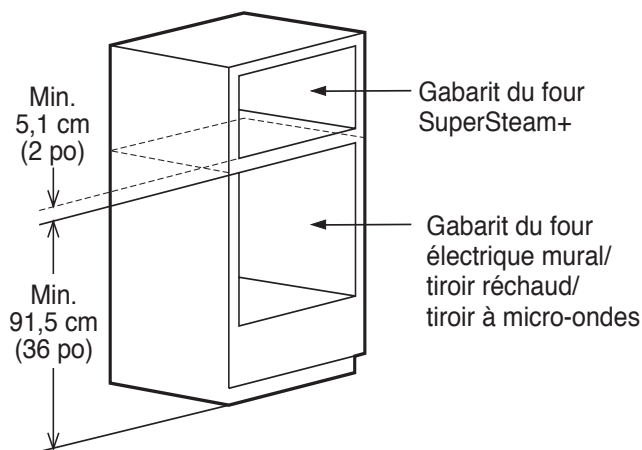

GROUNDING INSTRUCTIONS

This appliance must be grounded. The oven is equipped with a cord having a grounding wire with a grounding plug. It must be plugged into a wall receptacle that is properly installed and grounded in accordance with the National Electrical Code and local codes and ordinances. In the event of an electrical short circuit, grounding reduces risk of electric shock by providing an escape wire for the electric current.

Permanent and Correct Installation

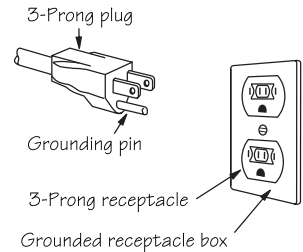

⚠ WARNING Improper use of the grounding plug can result in a risk of electric shock. **Do not use an extension cord. If the power supply cord is too short, have a qualified electrician or serviceworker install an outlet near the appliance.**

If you have any questions about the grounding or electrical instructions, consult a qualified electrician or service technician.

FOOD SAFETY

- Check foods to see that they are cooked to the United States Department of Agriculture's recommended temperatures.

160°F / 71°C - For fresh pork, ground meat, boneless white poultry, fish, seafood, egg dishes and frozen prepared food.

165°F / 74°C - For leftover, ready-to-reheat refrigerated; deli and carry-out "fresh" food.

170°F / 77°C - White meat of poultry.

180°F / 82°C - Dark meat of poultry.

To test for doneness, insert a meat thermometer in a thick or dense area away from fat or bone.

- Accessible parts (e.g., oven door, oven cavity, dishes and accessories) may become hot during use. Use dry potholders or oven mitts when removing containers, food and oven accessories from the oven, being careful not to touch the oven cavity to prevent burns.
- Use care when opening door. Avoid steam burns by directing steam away from the face and hands. Always stand back from the oven when opening it.
- Slowly lift the farthest edge of a dish's covering and oven cooking bags away from the face.
- Stay near the oven while it is in use and check cooking progress frequently so that there is no chance of overcooking food.
- NEVER use the cavity for storing cookbooks or other items.
- Select, store and handle food carefully to preserve its high quality and minimize the spread of foodborne bacteria.

INFORMATION YOU NEED TO KNOW

- Use care when removing items from the oven so that the utensils, your clothes or accessories do not touch the door projection.
- Do not touch around the oven light. This area will become hot when the oven light is on.
- To avoid burns, always be careful of splashing grease from the baking tray when removing roasted or grilled meats from the oven.
- To avoid burns, always test food and container temperature and stir before serving. Pay special attention to the temperature of containers, foods and drinks. Do not drink beverage or soup without checking the container's temperature.
- Do not touch the oven door, outer cabinet, rear cabinet, oven cavity, ventilation openings, accessories, dishes and the escaping steam from the air vent openings during operation because they will become hot.
- Do not operate the oven if reservoir cracks and water leaks. Call a Sharp Authorized Service Center to purchase a replacement part.
- After use, condensed water may be inside oven cavity, especially on the oven floor. Dry any liquid residue with a sponge and wipe out to keep the oven clean.
- Do not move the oven during its operation. If the oven needs to be moved, always drain all water inside the oven using the DRAIN WATER function (see page 24). After draining, empty the drip tray.
- To prevent condensation, which could corrode the appliance, do not leave cooked food in the oven for an extended period.
- Clean the oven at regular intervals and remove any food deposits in the oven or on the door.
- Do not use for deep frying.
- ALWAYS use potholders to prevent burns when handling utensils that are in contact with hot food. Enough heat from the food can transfer through utensils to cause skin burns. When using the Supersteam, Steam and Convection modes, the cabinet, interior and door may be too hot to touch.
- Do not pour cold water on the tempered glass oven floor after cooking as it might break. Do not use water to try to cool down the oven interior after use.
- Do not pour cold water on the door as it might break.
- Do not touch hot surfaces.
- The use of accessory attachments not recommended by the appliance manufacturer may cause injuries.
- The oven should not be left unattended during operation. Oven temperatures that are too high or cooking times that are too long may overheat foods resulting in a fire.
- Do not insert fingers or objects in the steam outlets or air vent openings. This may damage the oven and cause an electric shock or a hazard.
- If any objects drop inside the air vent openings, turn off the oven immediately, unplug and consult a Sharp Authorized Servicer.
- Do not touch the plug with wet hands when inserting or removing from the outlet. Plug securely into the electric wall receptacle and remove by gripping on the plug end. Never pull using just the cord.
- During steaming, steam may come from the right side of the vent.
- In the case of a grease fire, DO NOT USE WATER. Smother fire or flame or use dry chemical or foam-type extinguisher.
- Never use your appliance for warming or heating the room.
- Loose-fitting or hanging garments should never be worn while using the appliance.
- Do not heat unopened food containers. Buildup of pressure may cause container to burst and result in injury.
- Always place oven racks in desired location while oven is cool. If rack must be moved while oven is hot, use caution in order to prevent burns.

CHILDREN AND APPLIANCE SAFETY

Children below the age of 7 should use the oven with a supervising person very near to them. Between the ages of 7 and 12, the supervising person should be in the same room.

The child must be able to reach the oven comfortably; if not, he/she should stand on a sturdy stool.

At no time should anyone be allowed to lean or swing on the oven door.

Children should be taught all safety precautions.

Don't assume that because a child has mastered one cooking skill he/she can cook everything.

Children need to learn that the oven is not a toy. Young children should be supervised to ensure that they do not play with the oven.

Children should not be left alone or unattended in area where appliance is in use. They should never be allowed to sit or stand on any part of the appliance.

Do not store toys or other items of interest to children in drawers or in cabinet or counter areas near the oven so children will not risk injury trying to reach them.

INFORMATION YOU NEED TO KNOW

UTENSILS AND DISH COVERINGS

The chart will help you decide which utensils and coverings should be used in each mode.

UTENSILS - COVERINGS	COOKING MODE	
	SUPERHEATED STEAM (STEAM ROAST & STEAM GRILL) / CONVECTION	STEAM/STEAM BAKE
Aluminum Foil, Foil Containers	YES	YES
Metal	YES	YES
China, Ceramics, Porcelain, Pottery, Stoneware	YES	YES
Heat-resistant Glassware e.g., Pyrex®	YES	YES
	Care should be taken if using fine glassware as it can break or crack if heated suddenly.	
Non-heat-resistant Glassware	NO	NO
Heat-resistant Plastic/Polystyrene	NO	YES
	Check manufacturer's temperature range.	Care must be taken as some containers warp, melt or discolor at high temperatures.
Plastic, Thermoset®	NO	YES
Microwave Plastic Wrap	NO	NO
Paper Towels, Paper Plates	NO	NO
Parchment Paper	NO	YES
Wax Paper	NO	NO
Roasting Rack	YES	NO
Roasting Bags	YES	NO
	Roasting bags should only be used with convection bake or steam roast.	
Silver Dishes and Cooking Utensils or Containers that might rust inside the oven	NO	NO
Low Rack, High Rack, Baking Tray, Steam Basket	YES	YES
Silicone-based Cookware	NO	NO

ACCESSORIES

There are many heat-resistant accessories available for purchase. Evaluate carefully before you purchase so that they meet your needs. Sharp is not responsible for any damage to the oven when accessories are used.

For automatic cooking, (see Smart Cook and Smart Recipe sections), use the recommended container in the cooking chart in this operation manual.

PRODUCT OVERVIEW

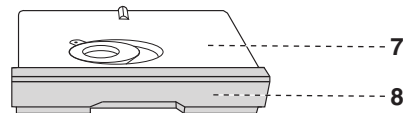
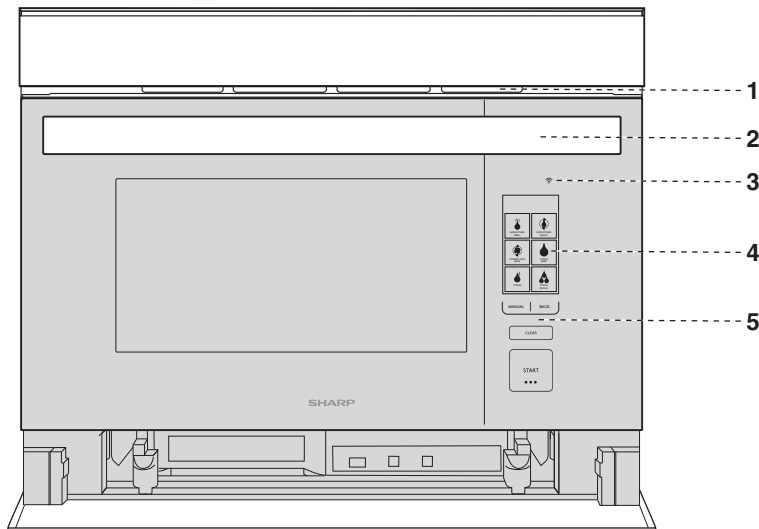

PARTS

- 1 Air vent opening
- 2 Handle
- 3 Wi-Fi connecting
- 4 LCD display
- 5 Control panel
- 6 Drip tray (see page 13)
- 7 Reservoir lid (see page 13)
- 8 Reservoir (see page 13)
- 9 Stage light
- 10 Oven light
- 11 Anti-tip stubs
- 12 Tray guide
- 13 Upper level
- 14 Lower level
- 15 Door hinges
- 16 Latches
- 17 Air deflector
- 18 Glass oven floor
- 19 Door gasket

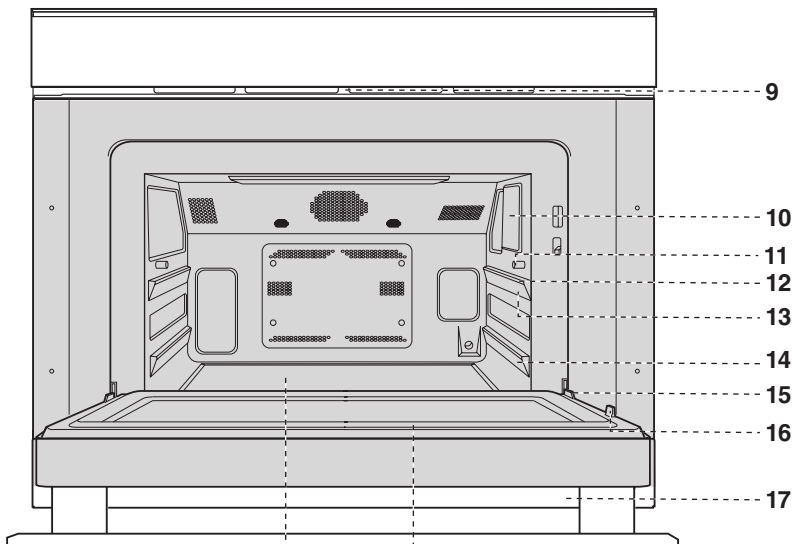

18 19

ACCESSORIES

- 20 2 Trays
- 21 2 Racks

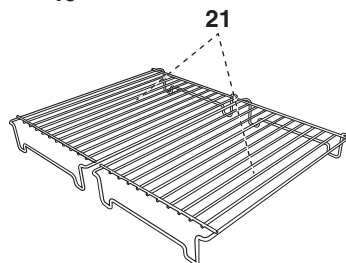
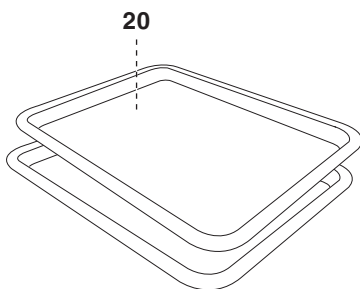

PRODUCT OVERVIEW

CONTROL PANEL

Numbers next to the control functions indicate pages on which there are feature descriptions and usage information.



STAGE LIGHT

The oven has an LED light that shines down to beautifully illuminate your cuisine. This light is useful for checking doneness after cooking to determine if more time is needed, or for taking a photograph to share with your friends.

FOR BEST USE:

CAUTION Always use caution when opening the oven door. The oven door, oven interior, racks, trays, cooking dishes and steam are extremely hot, and will cause injury if you touch any of the interior or stand with your face directly in front of the exiting steam. Use dry oven mitts or potholders to handle the trays.

1 Open the door completely and let it lie flat horizontally after cooking cycle has completed.

2 Carefully slide the cooking tray to rest in the bottom position on the door. This is the optimal position to take advantage of the stage light.

3 Slowly lift the farthest edge of a dish's covering and oven safe cooking bags away from the face.

4 Check food for doneness, using the United States Department of Agriculture's recommended temperatures.

5 If food requires additional cooking time, carefully slide the tray back into the oven and follow the instructions on the keypad to add additional cooking time.

6 Photograph food and share with your friends on social media if desired.

7 When finished, remove the food and carefully slide the tray back into position inside of the oven.

READ CAREFULLY BEFORE COOKING

WATER RESERVOIR

Filling the reservoir with fresh cold tap water is necessary for all Steam functions in both Smart and Manual Cooking. Follow the directions below before cooking.

- 1 Pull the reservoir toward you to remove.
- 2 Wash the reservoir and lid for first time use.
- 3 Fill the reservoir with fresh cold tap water through the lid to the 2 mark each time you begin to cook. Do not fill the reservoir over the 2 mark.

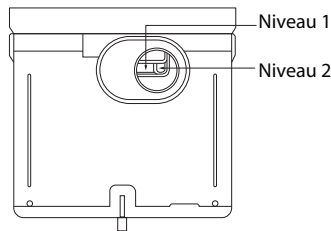

- 4 Close the lid tightly.
- 5 Reinstall the reservoir, pushing it firmly into place.
- 6 After cooking, empty the reservoir and wash the reservoir and the lid.

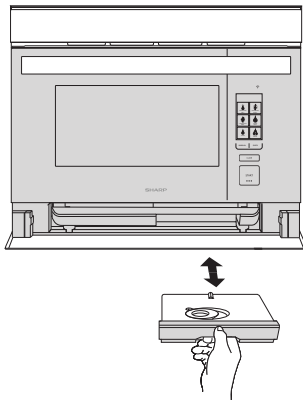

NOTES:

- 1 Do not use distilled water or any other liquid.
- 2 An insufficient amount of water in the reservoir may cause an undesired result.
- 3 We recommend that you empty the reservoir every time after cooking. Do not leave the reservoir filled with water in the oven over a day.
- 4 If any messages regarding low levels of water in the water reservoir (e.g., “Fill water reservoir”) show on the display during cooking, remove reservoir and refill water.
- 5 Do not drop or damage the reservoir. Heat may cause the reservoir to change shape. Do not use a damaged reservoir. Call a Sharp Authorized Service Center to purchase a replacement part.
- 6 There may be a few water drops when removing the reservoir. Wipe the oven dry with a soft cloth.

- 7 Do not block the air holes on the lid of the reservoir. It will cause trouble during cooking.
- 8 A small amount of water will drain into the drip tray when the reservoir is removed. Empty after cooking.

DRIP TRAY

The drip tray must be in the correct position while cooking. For proper operation, follow the directions below.

The drip tray is packed with the oven. Place the drip tray under the oven door as shown below. This drip tray collects the condensation from the oven door.

To remove the drip tray: Pull the drip tray toward you with both hands. Water should not be dripping before removing the drip tray.

To replace the drip tray: Place the drip tray onto the right and left hooks under the oven and push firmly as shown below.

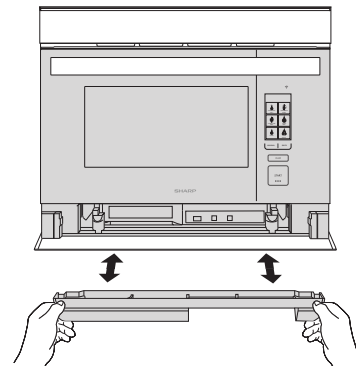

If “Replace drip tray” or “Empty drip tray and replace” is shown on the display, remove and replace the drip tray correctly.

Empty the drip tray each time after cooking. Empty, rinse thoroughly, dry and replace. Cooking repeatedly without emptying the drip tray may cause it to overflow.

WARNING

- 1 The oven will become very hot after cooking and draining water functions.
- 2 Do not open the oven with your face close to the oven. Steam from the oven may cause burns.
- 3 Wait until the oven has cooled before emptying the reservoir and the drip tray. Then, wipe the oven cavity.
- 4 Do not touch the water directly as water in the drip tray may be hot.

Before operating your new oven, read and understand this operation manual completely.

Before the oven can be used, follow these steps:

- 1 Place the drip tray correctly. See Drip Tray section on this page.
- 2 Close the door. Plug in the oven. Check that the display lights.
- 3 Follow directions in the NEW OVEN CLEAN section on page 14 to clean the oven before first use.

BEFORE FIRST USE

CLEAR

Press the CLEAR button to:

- 1 Return to Home Screen.
- 2 Cancel a program during cooking.

BACK

Press BACK if you want to go back to the previous page during programming before pressing START. After pressing START, it is not possible to return to a previous page.

NEW OVEN CLEAN

The steam generator heats the water that is used for cooking. It should be cleaned before the first use to get rid of any odor in the oven cavity. Clean the oven with New Oven Clean in manual operation for 20 minutes without preheat and food. You may notice some smoke and odor during this process. This is normal and the oven does not require servicing.

PREPARATION

- 1 Ventilate the room.
- 2 Fill the reservoir with fresh cold tap water and install.
- 3 Install the empty drip tray.

TO CLEAN THE OVEN BEFORE USE, FOLLOW THESE STEPS.

- 1 Select CLEAN from the Home Screen.
- 2 Select NEW OVEN CLEAN from the list provided.
- 3 Insert all accessories (i.e., two trays, two racks) into the oven.
- 4 Fill the reservoir with fresh cold water. Replace reservoir and press START.
- 5 Once NEW OVEN CLEAN is complete, use caution in opening the oven.

WARNING

- 1 The oven door, outer cabinet and oven cavity will become hot.
- 2 Do not open the oven with your face close to the oven. Steam from the oven may cause burns.

CONNECTING TO YOUR APPLIANCE

The next generation of SuperSteam+ Oven combines the technological enhancements of smart home connectivity with Sharp's innovative fusion of superheated steam and convection cooking oven design:

- Wi-Fi Connectivity
- Mobile App and Voice Control
- New GUI (Graphical User Interface) on oven
- Ability to Upload Favorite Recipes to the oven

Your SuperSteam+ Oven may be operated remotely through a smart device using the SuperSteam+ Oven app in addition to conventional operation in a non-connected capacity using the Control Panel on the oven door. Please be aware that some menu items are only available through download to the oven using the app. To use the app, the appliance must be connected to your home network.

WI-FI CONNECTIVITY

Your steam oven is equipped with Wi-Fi connectivity. The connection is set up manually as outlined in the Wi-Fi CONNECT GUIDE included with the appliance literature.

FAVORITES:

The SuperSteam+ Oven app lets you select and store your Favorite Smart Cook and Smart Recipes in your FAVORITES section.

Click on the heart icon to add your most frequently prepared dishes and upload the presets to your oven for convenience. You may store up to 4 Favorites for Smart Cook and 4 Favorites for Smart Recipe items at a time.

REMOTE START SAFETY INFORMATION

The oven is preset to Remote Start OFF. It must be turned ON to utilize.

When using smart device operation to control the appliance remotely, be sure to follow all safety procedures and guidelines as instructed in the Operation Manual. Failure to do so may result in personal injury, death or damage to property.

IMPORTANT INFORMATION YOU NEED TO KNOW BEFORE USING THE APP TO COOK!



Remote Start must be enabled on the oven control panel before the app may be used to control the oven remotely. This must be done after successfully pairing the app with your oven. (See Wi-Fi Connect Quick Start Guide included with instruction materials for step-by-step instructions on pairing.)

WARNING: If the feature has not been enabled, you must START, PAUSE and CANCEL all preheat and cooking functions at the oven control panel.

Failure to enable REMOTE START may result in the following 2 conditions:

- 1 The app will send a cook menu to download to your oven, but the app will remain fixed in a WAITING mode.
- 2 The app may appear to sync and mirror the preheating and cooking processes, and it may even appear to cancel cooking processes, but the app is not controlling the oven. Once preheating or cooking has started, it **MUST** be stopped at the oven.

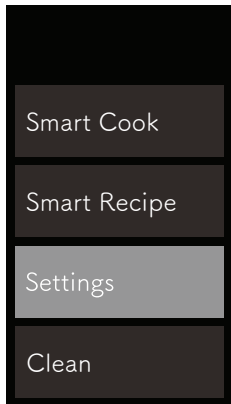
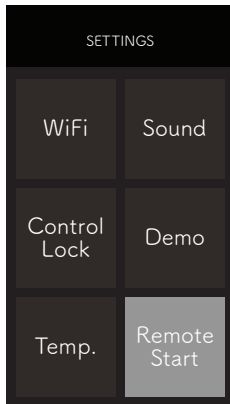
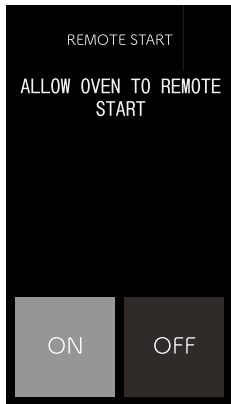
TO ENABLE:

 <p>1. Press Settings pad.</p>	 <p>2. Press Remote Start pad.</p>
 <p>3. Press On pad.</p>	 <p>4. Press Clear button on oven panel to exit.</p>

Now, all preheating and cooking may be started and stopped using your app.

IMPORTANT NOTE:

- If you activate the appliance remotely, your oven will remain ON and in cooking mode even if your smart device or home Wi-Fi becomes disabled.
- ALWAYS ensure the oven cavity is prepared for cooking when operating the oven remotely with the app. Risk of oven damage or fire could occur. NEVER use the oven interior as a storage device for unrelated items or cook using the app remotely if the cavity is not properly prepared.
- Your oven's Wi-Fi menu will have a pad for CONNECTING and a pad for PAIRING.
 - CONNECTING may be used if a new router is installed in the home and the oven needs to be connected to the Wi-Fi network again.
 - PAIRING may be used if you need to pair your oven to your smart device again and your oven is already connected to the Wi-Fi network.

CONNECTING TO YOUR APPLIANCE

OVEN DISPLAY PANEL OPERATION INACTIVITY NOTE

Condition 1: Non-Interaction with the oven after 20 Minutes of Initiating Cycle

Any navigation taken on the Oven Display Panel is subject to a 20-minute inactivity countdown.

This simply means that after 20 minutes of non-interaction with the oven, the Oven Display Panel will return to the HOME screen (i.e., if the option SMART COOK is touched and no other interaction is made for 20 minutes, the Oven Display Panel will default back to the Home screen).

Condition 2: Non-Interaction with the oven after 20 Minutes upon Preheat Completion

If a Preheat cycle has completed, it is subject to the 20-minute inactivity countdown if there is no interaction with the oven. This simply means that after 20 minutes of non-interaction with the oven, the Oven Display Panel will return to the HOME screen.

However, if after the oven is preheated, the door is opened and closed, there is a 10-minute inactivity countdown. (Note: the 10-minute inactivity countdown is only applicable after preheating and the door has been opened and closed.) If no interaction with the oven is performed after the opening and closing of the door after the preheat has completed, the Oven Display Panel will return to the Home screen.

FIRMWARE UPDATES

From time to time, updates to the oven's software will be released. Notifications will be sent via the SuperSteam+ Oven app for these updates. The firmware updates will be available on the product support page. Please visit www.sharpsusa.com/support for more information.

UNPAIRING YOUR DEVICE

To remove the pairing of your smart device with the oven, perform the following steps in your app:

- 1 Select Profile.
- 2 Select My Appliances.
- 3 Swipe Left over the bar that lists your Sharp SuperSteam+ Oven Default.
- 4 Press the icon on the right to unpair the oven from the smart device. This should remove the SuperSteam+ Oven from your appliances list.

COOKING OPERATION

The SuperSteam+ Oven encompasses multiple cooking functions to allow for flexibility and high performance for the best results.

The array of functions ranges from traditional dry heat convection cooking to steam to superheated steam that provides moisture and browning in tandem. Please see below for the categories and capabilities of this unique oven.

- Cooking modes include manual, smart cook and smart recipe.
- Manual mode allows you to fully create your own culinary experience.
- Smart cook guides you through quick and convenient preset cooking options for commonly prepared snacks, meals and desserts.
- Smart recipes are accessed through the app to guide you step by step in creating delicious appetizers, side dishes, entrées and desserts.

MANUAL COOK

The Manual cooking option allows you the freedom to choose and explore the full range of cooking features the SuperSteam+ Oven has to offer. Each manual cooking option is equipped with its specialized function to ensure optimum cooking performance.

NOTE: SPEED COOKING—THE 25-25 RULE

Overall, food cooked in a “Convection Bake” and “Superheated Steam” cook mode is usually done about 25% faster than it is in a conventional oven. Simple Estimation—given a time and temperature from a recipe instruction, reduce the temperature by 25° and the time by 25%. Example: instruction given is 400°F and 20 minutes. Convert to 375°F and 15 minutes.

IMPORTANT: All foods vary so always adjust accordingly for doneness. Refer to required meat doneness guidelines.

THERE ARE 5 MAIN COOKING FUNCTIONS IN MANUAL COOK:

1. STEAM COOK – STEAM GENERATOR CREATES STEAM WHICH IS INSERTED INTO THE OVEN

Steam Cook lets you steam meals of vegetables and delicate fish and meats. Pure steam retains nutrients and moistness. This is ideal for broccoli, salmon, cod and chicken. This works wonderfully to boil eggs or cook your favorite tamales.

Temperature 212°F - Pure steam

Steam Keep Warm is the best option for items such as casseroles, vegetables and quiches that you want to retain moisture while keeping warm.

Temperature 175°F - Using steam, controls the oven temperature.

Steam Refresh restores the original freshness to leftover dishes such as French bread, hamburger, brown rice, spaghetti noodles and broccoli.

Temperature 130°F - Using steam, controls the oven temperature.

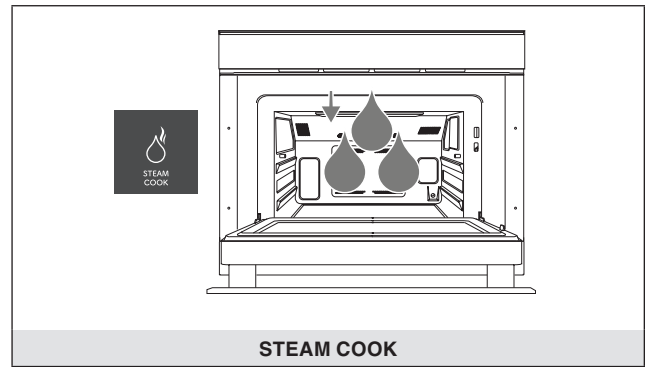

2. STEAM BAKE – COMBINATION OF CONVECTION HEAT AND STEAM

Steam Bake Breads creates delicious bread by injecting steam into the oven during the preheat cycle to promote even rising without the need for spritzing or handling hot pans of water. The setting automatically switches to dry convection heat to produce the desired light and airy interior and golden, crispy outer crust.

Temperature 400°F- 425°F

Steam Water Bath bakes creamy desserts such as cheesecake, pudding and custard that normally require a water bath method without handling hot pans of water.

Temperature 275°F - 300°F

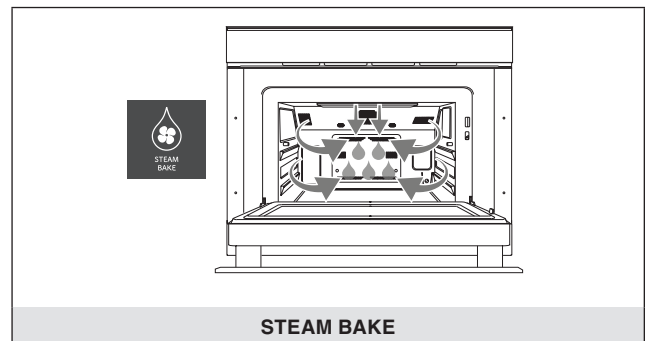

Steam Proof dough for breads. The proof function encourages fermentation of dough by yeast through warm temperatures and controlled humidity.

Temperature 100°F

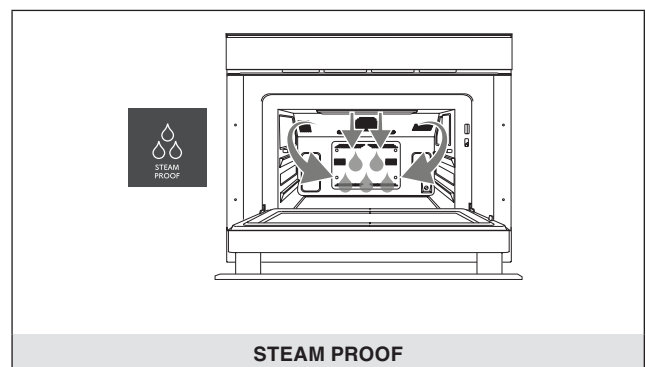

COOKING OPERATION

3. CONVECTION BAKE - DRY HEAT

Convection Bake - Bake traditional and convenience food items such as cookies, cakes, biscuits, pizzas and chicken nuggets using dry heated air that circulates evenly throughout the oven.

Temperature 212°F- 485°F.

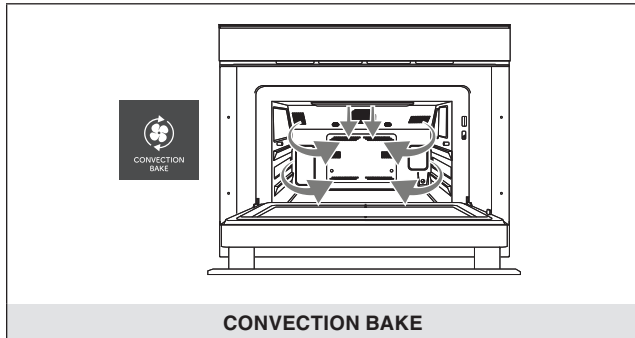

4. SUPERSTEAM GRILL - SUPERCHARGED STEAM AT 485°F

SuperSteam Grill - Create delicious grilled and sautéed items such as fish, vegetables, onions and steak. This setting works like the broil function in a traditional oven for food that cooks for shorter lengths of time at high heat. Give your dish the benefit of steam moistness with targeted superheated steam to create browning.

Temperature 485°F

Top Convection Grilling

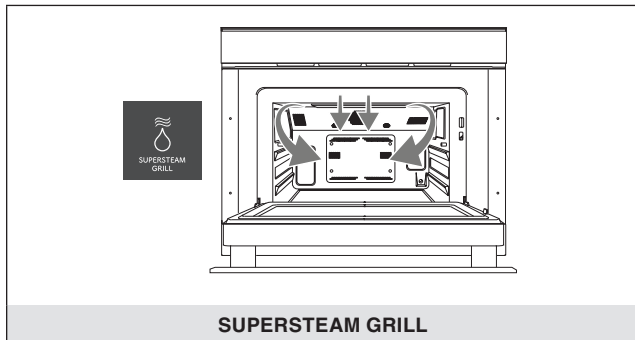

5. SUPERSTEAM ROAST - SUPERCHARGED STEAM AT 212°F - 485°F

SuperSteam Roast - Roast dishes such as chicken (whole), sweet potato and beef or pork roast. Incorporating steam for food that requires longer cooking times allows it to brown on the outside while maintaining a moist and tender texture inside.

Temperature 212°F - 485°F

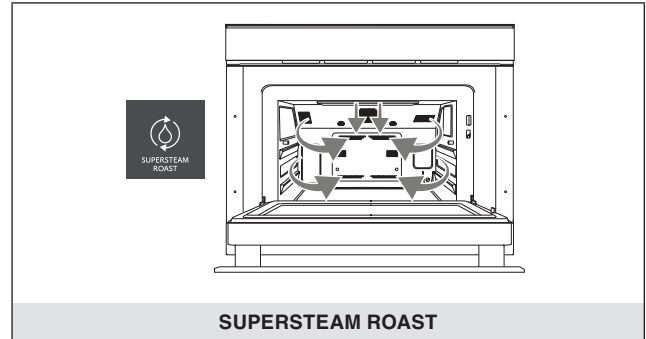

COOKING WITH STEAM

Overall, food cooked in a “Convection Bake” and “Superheated Steam” cook mode is usually done about 25% faster than it is in a conventional oven. Simple Estimation—given a time and temperature from a recipe instruction, reduce the temperature by 25° and the time by 25%.

Example: instruction given is 400°F and 20 minutes. Convert to 375°F and 15 minutes.

IMPORTANT: All foods vary so always adjust accordingly for doneness. Refer to required meat doneness guidelines. The Sharp SuperSteam+ Oven also has several Smart Cook settings that are preset cook modes, temperatures and times for a number of select foods to help you to become familiar with the oven’s cooking performance.

Steam options can be used for smart cook, manual cook and smart recipe modes. See more information about using the various steam options in the descriptions on page 17 in the Manual Cooking section.

STEAM CHART

HOME PAGE	MENU SETTING	EXAMPLES	TEMP SETTINGS
STEAM COOK	STEAM COOK	Fish, Vegetables	212°F
	STEAM KEEP WARM	Dinner Plate	175°F
	STEAM REFRESH	Fresh Bread	130°F
STEAM PROOF		Bread Dough	100°F

COOKING OPERATION

- To cook using SUPERSTEAM ROAST manually:

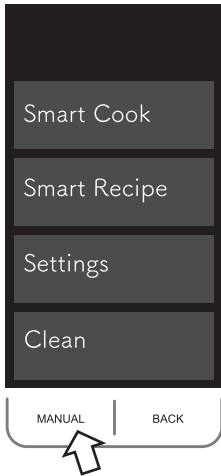

1. Press MANUAL.

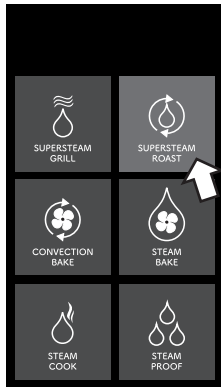

2. Press SUPERSTEAM ROAST.

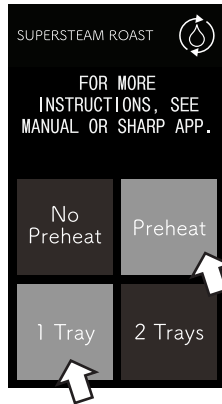

3. Select preheat preference and number of trays.

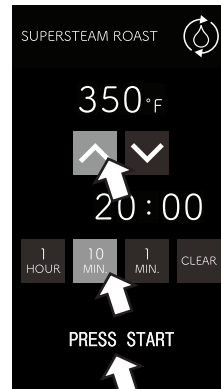

4. Select temperature and time then press START.



5. Oven is preheating.



6. Place food in the oven.

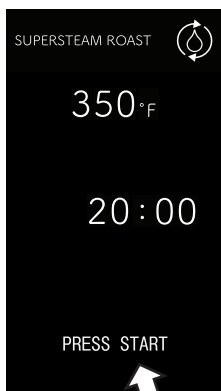

7. Press START.

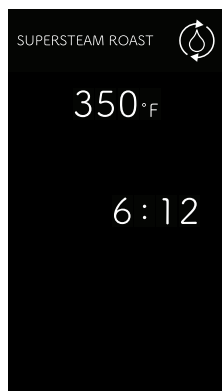

8. Cooking time counts down.



9. Finished cooking.

Option for more cooking time:

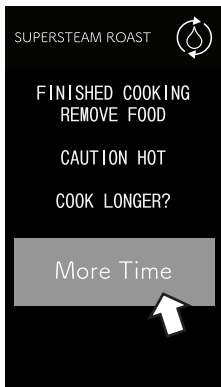

10. To add more cooking time, press MORE TIME.

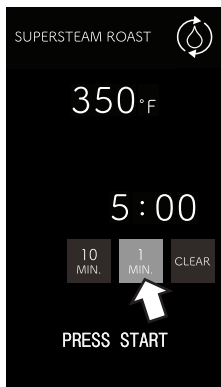

11. Press numbers to add more time, then press START.

COOKING OPERATION

SMART RECIPE

Smart Recipe uses our app to guide you step by step in discovering dishes that have been carefully created for the SuperSteam+ Oven by our chef and tested in our Sharp Test Kitchen. The oven comes preloaded with 12 menu presets for cooking time and temperature (e.g., Lemony Cedar Plank

Salmon, Chocolate Pots de Crème and Stuffed Portabellas with Spinach). As you experiment with new recipes on the app, you will discover new favorites which you can upload to your oven for easy access at the control panel (a total of 4 favorites may be stored at one time).

SMART RECIPE CHART

FOOD CATEGORY	FOOD ITEM	SERVING SIZE	COOKING MODE	TOTAL COOK TIME (MINUTES)
Main Dishes	Lemony Cedar Plank Salmon	2	SuperSteam Grill	8
	Turkey Burgers	4	SuperSteam Grill	14
	Baby Back Ribs	4	SuperSteam Roast	85
			SuperSteam Grill	5
Stuffed Portabellas with Spinach	2	SuperSteam Roast	8	
Side Dishes	Herb Roasted Fingerling Potatoes	4	SuperSteam Roast	25
	Sweet Potato Salad	4	Steam	14
	Roasted Brussels Sprouts	4	SuperSteam Roast	20
	Parmesan Cauliflower	4	SuperSteam Roast	15
Desserts	Mixed Berry Crumble	8	SuperSteam Roast	30
	Chocolate Chip Zucchini Cake	9	Convection Bake	35
	Chocolate Pots de Crème	4	SuperSteam Roast	25
	Morning Glory Bread	8	Convection Bake	50

COOKING OPERATION

SMART COOK

Smart Cook guides you through quick and convenient preset cooking options for weight, cooking time and temperature for commonly prepared items. Your SuperSteam+ Oven comes preloaded with 12 food presets (e.g., Tater Tots, Bacon and Steamed Asparagus). More are available in the SuperSteam+ Oven app. The app also provides tips and creative ideas to help you achieve the best results and discover new favorites which you can upload to your oven for easy access at the control panel (a total of 4 favorites may be stored at one time).

NOTE: The menus included in the automatic cooking options include suggested amounts and average cooking times. Please note that different brands of food items can vary in shape, size, quantity and weight. Please be sure to monitor the food items during cooking to ensure satisfactory completion of the selected automatic menu item.

SMART COOK CHART

FOOD CATEGORY	FOOD ITEM	QTY / WEIGHT	COOKING MODE	TOTAL COOK TIME (MINUTES)
Snacks/Pizza	Fried Breaded Shrimp	16	SuperSteam Roast	10
	Tater Tots	1/2 bag	SuperSteam Roast	20
	Thin Crust	1-10"	Convection Bake	15
	Classic Crust	1-10"	Convection Bake	18
Meat/Fish	Bacon (Thick-Cut)	6 slices	SuperSteam Grill	10
	Drummies/Wingette Pieces	1 lb	SuperSteam Grill	25
	Salmon	6 oz filets (2 each)	Steam	14
	Shrimp	20 (med 26/30 ct)	Steam	5
Fresh Vegetables	Sweet Potatoes	4	SuperSteam Roast	40
	Asparagus	1 lb (30 each)	Steam	8
	Cauliflower/Broccoli	3 servings	Steam	8
	Zucchini/Squash	3 servings	Steam	10

SETTINGS AND DEMO MODES

SETTINGS

In the event that the electrical power supply to your oven should be interrupted, your current input settings will be erased. Simply reset the settings once power is reinstated to the oven.

SOUND

At the end of timed cook or touch of the screen, beeps will sound. The audible signal can be turned off if you prefer quiet operation. Sound is on by default.

TO TURN SOUND OFF

- 1 Press SETTINGS.
- 2 Press SOUND.
- 3 Press OFF.
- 4 Press CLEAR to exit.

TO RESTORE SOUND

- 1 Press SETTINGS.
- 2 Press SOUND.
- 3 Press ON.
- 4 Press CLEAR to exit.

CONTROL LOCK

The Control Lock prevents unwanted oven operation such as by small children. The oven can be set so that the control panel is deactivated or locked.

TO LOCK

- 1 Press SETTINGS.
- 2 Press CONTROL LOCK.
- 3 Hold BACK button for 3 seconds.
- 4 Display shows CONTROL LOCK IS ON.

TO UNLOCK

- 1 Hold BACK button for 3 seconds.
- 2 Display shows CONTROL LOCK IS OFF.
- 3 Press CLEAR to exit.

TEMP

The oven is preset to °F. To change, press SETTINGS then TEMP. Once selection is made, press CLEAR to exit.

DEMO MODE

There are 2 demonstration options available within the Settings menu for learning more about the SuperSteam+ Oven: Video Demo and Working Demo.

VIDEO DEMO

Video Demo mode takes you on a guided tour of the Smart Recipe mode for preparing Lemony Cedar Plank Salmon and the Smart Cook mode to cook Chicken Drumsticks/Wingette Pieces. The video demonstration will continue in a loop until you press CLEAR to exit.

To enter Video Demo

- 1 Press SETTINGS.
- 2 Press DEMO.
- 3 Press VIDEO DEMO.
- 4 Press CLEAR to exit.

WORKING DEMO

Working Demo mode allows you to explore and learn the oven's different functions and cooking modes while the oven is not operational in a cooking capacity. Working Demo mode must be started on the Oven Panel (it cannot be started from the app), but you may use your smart device to send commands to oven from the app while the oven is in Working Demo mode. (In Working Demo, the fan motor will still run, but the oven will not produce heat.) The DEMO icon will appear on the display panel until the steps are taken to turn OFF Working Demo mode.

To enter Working Demo Mode

- 1 At Home Page hold CLEAR until it beeps.
- 2 Press CLEAR 4 times rapidly.
- 3 The DEMO icon will appear on the screen.
- 4 Proceed in DEMO MODE.

To exit Working Demo Mode

- 1 Repeat steps 1 and 2.
- 2 The DEMO icon will be removed.

Note:

- Oven does not heat in Demo Mode.
- Display counts down quickly.

The Sharp SuperSteam+ Oven offers many options to keep the oven clean. From initial cleaning of your new oven to periodic cleaning, the CLEAN menu helps to keep the oven in peak operational condition and maintain a sparkling and fresh appearance.

NEW OVEN CLEAN

This is to be used initially to clean the cavity and the accessories that come with this oven before actual cooking. It is recommended to use New Oven Clean before cooking in the oven in order to ensure starting with fresh, clean cooking instruments.

- 1 Select CLEAN from the home page.
- 2 Select NEW OVEN CLEAN from the list provided.
- 3 Insert all accessories (i.e., two trays, two racks) into the oven. Fill the reservoir with fresh cold water. Replace reservoir and press START.
- 4 Once NEW OVEN CLEAN is complete, use caution in opening the oven.

WARNING

- 1 The oven door, outer cabinet and oven cavity will become hot.
- 2 Do not open the oven with your face close to the oven. Steam from the oven may cause burns.

STERILE CLEANSE

The Sterile Cleanse function assists in cleaning specific items that require extra care in cleanliness. The chart below lists the items that can be used during this function.

- 1 Select CLEAN from the home page.
- 2 Select STERILE CLEANSE from the list provided.
- 3 Select desired level. Please see chart below for suggested items to cleanse on upper or lower level.
- 4 Fill the reservoir with fresh cold water. Replace reservoir and press START.
- 5 Once STERILE CLEANSE is complete, use caution in opening the oven. The door, cabinet and oven may be very hot. Do not open with your face close to the oven. The steam from the oven may cause burns.

LEVEL SELECT	SUGGESTED ITEMS FOR CLEANSING
Upper Level (Rack & Tray)	Canning (Jars and Lids)
Lower Level (Tray)	Blanching Small Cutting Boards

DESCALE

White or gray grains, also called scale, may form in the water circuit inside the oven during steam generation, which could cause the oven to malfunction. The Descal functions helps to break down this scale and keep the oven clean and looking like new.

- 1 Select CLEAN from the home page.
- 2 Select DESCAL from the list provided.
- 3 Fill the reservoir with a mixture of either water and citric acid or lemon juice. Please see chart below for suggested amounts. Replace the reservoir and press START.
- 4 Once oven has completed the cycle, allow the oven to cool down. Then, wipe away any residue remaining with a damp cloth.
- 5 Remove the reservoir, empty, rinse and refill with tap water. Replace reservoir and press START.
- 6 Once the DESCAL function is complete, allow the oven to cool down.
- 7 Once cool, wipe oven cavity to dry. Empty the drip tray.

MIXTURE	AMOUNT
Water and Citric Acid	2 ¹ / ₄ cups water and 1 tablespoon citric acid crystals. Dissolve crystals into water and pour into reservoir.
Water and Lemon Juice	2 ¹ / ₄ cups water and 1/3 cup 100% lemon juice (no pulp). If the lemon juice contains pulp, please strain. Stir well and pour into the reservoir.

Please do not fill the reservoir with alternative cleaning agents not specified in the chart above. Other cleaning agents may damage your SuperSteam+ Oven.

OVEN STEAM CLEANING

The Oven Steam Clean function helps to loosen any grease, oil or food residue. The steam will make the oven easy to clean; however, it is not a self-cleaning function.

- 1 Select CLEAN from the home page.
- 2 Select OVEN CLEANING – STEAM from the list provided.
- 3 Fill the reservoir with fresh, cold water. Press START.
- 4 Once the OVEN CLEANING – STEAM function is complete, allow the oven to cool down.
- 5 Once cool, wipe any residue remaining with a soft, damp cloth.

CLEANING

EXTERIOR

The outside surface is precoated metal and plastic. Clean the outside with mild soap and water; rinse and dry with a soft cloth. Do not use any type of household or abrasive cleaner.

STAINLESS STEEL SURFACE

The exterior should be wiped often with a soft damp cloth and polished with a soft dry cloth to maintain its beauty. There are also a variety of products designed especially for cleaning and shining the stainless exterior of the oven. We recommend that the cleaner be applied to a soft cloth and then carefully used on the stainless exterior rather than sprayed directly on to it. Follow package directions carefully.

FRONT SIDE OF THE OVEN

Wipe the window on both sides with a soft damp cloth to remove any spills or splatters. Metal parts will be easier to maintain if wiped frequently with a soft damp cloth. Avoid the use of spray and other harsh cleaners as they may stain, streak or dull the oven surface.

TOUCH CONTROL PANEL

If desired, the touch pads may be deactivated before cleaning. See the Control Lock information on page 22 of this manual. Wipe the panel with a cloth dampened slightly with water only. Dry with a soft cloth. Do not scrub or use any sort of chemical cleaners. Close oven and follow directions on page 22 for turning Control Lock off. Press CLEAR.

INTERIOR

Cleaning is easy because no heat is generated to the interior surfaces; therefore, there is no baking and setting of spills or spattering. To clean the interior surfaces, including oven sealing surfaces, wipe with a soft damp cloth. **DO NOT USE ABRASIVE OR HARSH CLEANERS OR SCOURING PADS.** For heavier soil, use mild soap; wipe clean with a soft damp cloth. Do not use any chemical oven cleaners.

ODOR REMOVAL

Occasionally, a cooking odor may remain in the oven. To remove odor, combine 1 cup water with $\frac{1}{3}$ cup lemon juice in a 2-cup glass. Boil for several minutes. Leave in the oven until water cools. Wipe interior with a soft cloth.

WATER DRAINING

In the event of excess water being in the SuperSteam+ Oven engine or a steam function that is interrupted during operation, your oven may need to drain to reset itself.

An ATTENTION message will be displayed alerting the need for the oven to drain the water.

Ensure that there is an empty reservoir. If not, empty the reservoir and replace.

The draining of the water into the reservoir will take approximately 1 minute.

Once complete, detach the reservoir and discard the water.

BEFORE YOU CALL FOR SERVICE

Please check the following before calling for service. It may save you time and expense.

PROBLEM	POSSIBLE CAUSE	SOLUTION
1 Part or all of oven does not operate.	<ul style="list-style-type: none"> • Power cord of oven is not completely connected to the electrical outlet. • Power outage. • Fuse/circuit breaker at home doesn't work. • Oven is in Demo Mode. 	<ul style="list-style-type: none"> • Make sure the power cord is tightly connected to the outlet. • Check house lights to be sure. Call your local electric company for service. • Replace the fuse or reset the circuit breaker. • See page 22 for how to cancel Demo Mode.
2 Food in oven is not heated.	<ul style="list-style-type: none"> • No power to the appliance. • Oven controls improperly set. • Oven is in Demo Mode. 	<ul style="list-style-type: none"> • See SOLUTION for PROBLEM 1. • Check if the controls have been properly set. • See page 22.
3 Oven light does not work.	<ul style="list-style-type: none"> • Light bulb is loose or burned out. 	<ul style="list-style-type: none"> • Call for service.
4 Touch controls will not operate.	<ul style="list-style-type: none"> • Control Lock is on. 	<ul style="list-style-type: none"> • See page 22 to unlock.
5 Display flashes.	<ul style="list-style-type: none"> • Power failure. 	<ul style="list-style-type: none"> • Press Clear pad and reset the clock. If the oven was in use, you must reset the cooking function.
6 My app won't start the oven preheat or cooking cycles properly.	<ul style="list-style-type: none"> • Is Remote Start turned ON? 	<ul style="list-style-type: none"> • See instructions on page 15 or the included Wi-Fi Connect Guide for further details to enable Remote Start.
7 I have to press START on the oven even though I pressed START PREHEAT or START COOKING on my app.	<ul style="list-style-type: none"> • Is Remote Start turned ON? 	<ul style="list-style-type: none"> • See instructions on page 15 or the included Wi-Fi Connect Guide for further details to enable Remote Start.
8 My app does not PAUSE, or STOP/CANCEL cooking properly; the oven continues cooking.	<ul style="list-style-type: none"> • Is Remote Start turned ON? 	<ul style="list-style-type: none"> • See instructions on page 15 or the included Wi-Fi Connect Guide for further details to enable Remote Start.

SHARP®

SHARP ELECTRONICS CORPORATION • 100 Paragon Drive • Montvale, New Jersey 07645 • USA

SHARP ELECTRONICS OF CANADA LTD • 335 Britannia Road East • Mississauga, Ontario • L4Z 1W9 • Canada