

SEDONA BY LYNX™



*Exclusive Sedona Island Packages are complete,
including the island*



MOM FRIENDLY. DAD READY.™

Mom Friendly. Dad Ready. All Sedona by Lynx™ products are designed with the family in mind.

Quality materials. Fine craftsmanship. Innovative features and technology. These attributes have earned Lynx products a reputation for excellence among outdoor-dining enthusiasts.

Created by a team with decades of experience meeting the demanding requirements of the commercial restaurant industry, Lynx products have always been designed to combine high performance and luxurious appearance with long-term durability for reliable year-round grilling.

The Lynx commitment to continuous innovation has introduced numerous industry firsts. Including a hood assist kit that makes raising and lowering the grill hood effortless. And ProSear™ infrared burners that allow unprecedented variable temperature control. Advances such as these have made the Lynx name synonymous with the best in outdoor cooking. And they make Sedona by Lynx an exceptional value for those in search of much more than an ordinary grill.





SEDONA BY LYNX™ – WELCOME TO A HIGHER STANDARD

The true value of a grill is in the cooking performance, ease of use and enduring beauty it brings to your outdoor kitchen. By every measure, Sedona by Lynx™ clearly stands apart.

As you'll see throughout the following pages, Sedona Grills and related accessories are designed in every detail to exceed your expectations and enhance your outdoor entertaining pleasure.

Crafted by the Lynx Grill specialists at our factory in Southern California, each Sedona Grill displays the meticulous fit and finish and high-quality materials that have made Lynx products favorites of grilling enthusiasts.

Sedona Grills are available in a wide variety of configurations. Endowed with innovative Lynx features, they set a higher standard for luxurious outdoor dining. By making it easier than ever to prepare great meals, cooked to perfection.



TECHNOLOGY AND QUALITY HIGHLIGHTS



PROSEAR™ VARIABLE SEARING TECHNOLOGY

- Unlike many grills with infrared searing burners that only offer two settings – hi or off – the Lynx ProSear™ infrared burner is variable
- You can sear a baseball-cut filet mignon restaurant style, then throttle back to cook delicate seafood like scallops
- This is the acclaimed ProSear™ burner for which Lynx has been known for years



FEATURES AND BENEFITS

The innovative features, unparalleled performance and superior craftsmanship of Sedona by Lynx™ Grills are available in 24", 30" and 36" configurations for built-in or freestanding applications.



STAINLESS STEEL BURNERS

Durable stainless steel tube burners with briquettes ensure instant ignition with steady and even heat distribution

Twelve Year Warranty



SUPERIOR FIT AND FINISH

All stainless steel construction

Continuously welded joints for quality, strength and beauty

Finished seams with finely polished edges



CONTROL KNOBS ILLUMINATED WITH BLUE LED LIGHTS

Each knob features dedicated LED lighting

Knob markings can easily be viewed at night

Single switch activation



INTERNAL HALOGEN GRILL SURFACE LIGHT

Effectively illuminates the entire grilling surface using a heavy-duty ceramic glass lens directly over the grilling surface

12 volt halogen light

FEATURES AND BENEFITS



SPARK IGNITION SYSTEM

Reliable spark ignition

Activated by burner control knobs

Battery back-up in event of a power failure



CERAMIC RADIANT BRIQUETTES

Specially designed high-density ceramic

Even heat across the entire grilling surface

Briquettes are clipped in place to facilitate easy cleaning

Enhances food's flavor as drippings hit the briquettes and turn to smoke



STAINLESS STEEL GRATES

Heavy-duty electro-polished stainless steel grates



TEMPERATURE GAUGE

Indicates when your grill is ready for cooking

Large and easy to read

Temperature gauge indicates internal temperature for indirect cooking

FEATURES AND BENEFITS



ROTISSERIE SYSTEM

Compact motor, easy to remove and store when not in use

Includes spit rod with two spit forks



REAR INFRARED BURNER

Rotisserie models feature a rear infrared burner

L600 36" Grills - 14,000 BTU

L500 30" Grills - 12,500 BTU

L400 24" Grills - 12,500 BTU



HOOD ASSIST KIT

Heat treated stainless steel spring system

Makes hood operation effortless and safe

Easy to remove for those who appreciate the heft



AMPLE GRILLING SURFACE

24" Grills - 575 square inches (398 primary / 177 secondary)

30" Grills - 733 square inches (508 primary / 225 secondary)

36" Grills - 891 square inches (618 primary / 273 secondary)



Shown
L2500S - Sandalwood*

L2500S ISLAND WITH 30" GRILL
AVAILABLE IN BOTH COLORS

SEDONA L2500/L2600 ISLAND PACKAGES

Create a fully featured outdoor kitchen in no time at all with a premium Sedona Island Package. Available in two color schemes, and offered with a choice of 30" or 36" grills, these Islands also include an outdoor-rated refrigerator, double-burner side burner and a combination storage system with two fully enclosed pull-out drawers. A 15" overhang along the rear of the island accommodates seating and a circular end counter extension adds extra space for entertaining.



Beautiful detailing throughout



Each island includes two USB charging stations



15" counter overhang accommodates seating along the rear

ISLAND PACKAGES - FEATURING 30" & 36" GRILLS



L2600 ISLAND WITH 36" GRILL - *available in both colors*

Model No. L2600G (shown above) / L2600S

BOTH ISLANDS FEATURE

92" x 47" half oval shape with a 47" diameter circular entertainment area feature on the right

15" counter overhang which runs along the back of the island and sweeps around the circular right end to accommodate additional seating

Has two diamond shaped tile features on the back side with a tile kick plate

Welded frame is 1" square tubing with galvanized protection

Premium grade outdoor rated concrete board substrate

Pre-wired with GFI protection for grill and refrigerator connections along with convenient electrical receptacle for rotisserie motor

Two USB charging ports standard

Island comes ready for gas connections and includes required venting

Leveling feet are standard

Tough acrylic stucco which is waterproof, UV resistant and long lasting

Sealed porcelain 6"x 6" tile is unglazed, frost proof, designed for outdoor use

Beautiful cross hatch tile pattern with a 3" border around the counter edges which include a bull nose and 3" vertical lip

Includes a tile border which frames the front of the grill and base on three sides

ALL ISLANDS ARE AVAILABLE
IN EITHER COLOR SCHEME



***SANDALWOOD**

Beige stucco base with oxy-iron (beige with orange highlights) tile countertop



***FALCON GRAY**

Light gray stucco base with oxy-chrome (dark green with brown highlights) tile countertop

ALL SEDONA ISLANDS ASSEMBLE IN MINUTES.

Sedona Islands are designed for easy delivery and quick setup. Delivered in a flat package sized to fit through typical backyard gates, they can be assembled within 30 minutes by two to three people using just a few tools.



SEDONA L1500/L1600 ISLAND PACKAGES

FEATURING 30" & 36" GRILLS

The convenience of an outdoor kitchen is easy to achieve with the essentials built into a classic Sedona Island. Choose from 30" or 36" grill sizes. Your island also includes an outdoor-rated refrigerator and a side burner, as well as doors for extra storage space and a 10" overhang along the rear of the island for seating, so guests can gather around the grill.



***FALCON GRAY**
Light gray stucco base with oxy-chrome (dark green with brown highlights) tile countertop



***SANDALWOOD**
Beige stucco base with oxy-iron (beige with orange highlights) tile countertop



L1600 ISLAND WITH 36" GRILL - *available in both colors*
Model No. L1600G

BOTH ISLANDS INCLUDE

L500REF - 20" outdoor rated refrigerator, 4.1 cu ft. capacity. Includes 3 wire shelves plus door storage and can dispenser in the door. Interior light.

LSB501 - Side burner with a 12,500 BTU sealed burner with blue LED illuminating the gas control knob. Standard with stainless steel cover and gas and electrical connections to grill.

L1600 ISLANDS INCLUDE

76" x 40" rectangular shape with a 10" counter overhang to accommodate seating along the rear.

L600PS Grill - 36" grill with 2 stainless steel tube burners and 1 ProSear™ burner, grill includes internal halogen hood light, blue LED lights over each gas control knob and many other features.

LDR636 - 36" double access doors allow access to utility connections below the grill and extra storage.

L1500 ISLANDS INCLUDE

71" x 40" rectangular shape with a 10" counter overhang to accommodate seating along the rear.

L500PS Grill - 30" grill with 1 stainless steel tube burner and 1 ProSear™ burner, grill includes internal halogen hood light, blue LED lights over each gas control knob and many other features.

LDR530 - 30" double access doors allow access to utility connections below the grill and extra storage.

ISLAND DIMENSIONS

L1600 - 76 1/8" long x 40 5/8" deep x 38" high

L1500 - 71 3/4" long x 40 5/8" deep x 38" high

L1500 ISLAND WITH 30" GRILL
available in both colors

Model No. L1500S



10" counter overhang accommodates seating along the rear



A BUILT-IN OF YOUR OWN



36" BUILT-IN GRILL

Model No. L600PSR (shown)

ProSear™ infrared technology delivers intense and controllable infrared heat

891-sq. in. cooking surface (618 primary, 273 secondary)

Stainless steel tube burner for extremely even cooking temperature

Superior fit and finish - continuously welded joints

Spark ignition system with battery back-up

Control illumination with blue LED lights

Internal halogen grill surface light

Specially designed high-density ceramic radiant briquettes

Large and easy-to-read temperature gauge

Hood Assist Kit

Rotisserie models include; Rear infrared burner, compact rotisserie motor, spit rod and two spit forks.

Stainless steel grilling grates

Dimensions - 36"W x 25"D x 25"H



30" BUILT-IN GRILL

Model No. L500PSR (shown)

ProSear™ infrared technology delivers intense and controllable infrared heat

733-sq. in. cooking surface 508 primary, 225 secondary)

Stainless steel tube burner for extremely even cooking temperature

Superior fit and finish - continuously welded joints

Spark ignition system with battery back-up

Control illumination with blue LED lights

Internal halogen grill surface light

Specially designed high-density ceramic radiant briquettes

Large and easy-to-read temperature gauge

Hood Assist Kit

Rotisserie models include; Rear infrared burner, compact rotisserie motor, spit rod and two spit forks.

Stainless steel grilling grates

Dimensions - 30"W x 25"D x 25"H



24" BUILT-IN GRILL

Model No. L400PS (shown)

ProSear™ infrared technology delivers intense and controllable infrared heat

575-sq. in. cooking surface (398 primary, 177 secondary)

Stainless steel tube burner for extremely even cooking temperature

Superior fit and finish - continuously welded joints

Spark ignition system with battery back-up

Control illumination with blue LED lights

Internal halogen grill surface light

Specially designed high-density ceramic radiant briquettes

Large and easy-to-read temperature gauge

Hood Assist Kit

Rotisserie models include; Rear infrared burner, compact rotisserie motor, spit rod and two spit forks.

Stainless steel grilling grates

Dimensions - 24"W x 25"D x 25"H



FREESTANDING MODELS FOR MOBILE CONVENIENCE

Enjoy the advanced grilling technology and superior craftsmanship of Sedona by Lynx™ in a form that's at home in any outdoor area—even small patios. Sedona Freestanding models offer a full range of grill sizes and convenience features. And they roll easily on heavy-duty castors, so you can quickly reposition your grill, or store it when you're not entertaining.



36" GRILL

Model No. L600PSR (shown)
with Model No. L600CART



30" GRILL

Model No. L500PSR (shown)
with Model No. L500CART



24" GRILL

Model No. L400PS (shown)
shown with Model No. L400CART

THE SEDONA BY LYNX™ COLLECTION

All Sedona by Lynx™ Grill Heads can be easily assembled to a matching cart. Cart arrives in a flat package and can be quickly assembled by two people in less than 20 minutes. Unique keyhole slot design provides simple assembly procedure only requiring a screwdriver.



SEDONA BY LYNX™ CARTS FEATURE

- Doors with rigid liners
- Internal storage shelf
- LP tank restraint system

SHIPPING WEIGHT/DIMENSIONS

- L600 Cart: 106 lbs. / 38"W x 34" D x 12"H
- L500 Cart: 86 lbs. / 34"W x 30"D x 12"H
- L400 Cart: 72 lbs. / 34"W x 24"D x 12"H



Elegant and Functional Lighting



Superior Craftsmanship



Optional Rotisserie System

COMPLEMENTARY PRODUCTS

Sedona offers a complete line of complementary products to allow you to fully equip your Outdoor Kitchen. This includes a variety of access doors, combination storage systems, side burners, a refrigerator, an insulating jacket and vinyl covers. Sedona adaptor kits allow Sedona to fit into a variety of existing island cutouts.



DOUBLE DOORS

Model No. LDR636/LDR530

- Doors with rigid liners
- Easily Installed
- Stainless steel handles
- Sized to grill width



STORAGE DOOR & FULLY ENCLOSED DOUBLE DRAWERS

Model No. LSA636/ LSA530

- Fully enclosed drawers for secure storage
- Slides keep drawers solidly in closed position
- Stainless steel handles
- Sized to match grill



24" SINGLE DOOR

Model No. LDR424

- Door has a rigid liner
- Easily Installed
- Stainless Steel handles
- Sized to grill width or for additional storage

COMPLEMENTARY PRODUCTS



20" OUTDOOR REFRIGERATOR

Model No. L500REF

- UL listed for outdoor use
- Seamless stainless steel exterior
- Interior light
- 4.1 cubic feet of usable capacity
- 3 wire shelves
- Can dispenser in drawer for convenience
- Additional door storage
- Reversible door (kit included)



17" ENCLOSED DOUBLE DRAWERS

Model No. LUD517

- Two 6" deep fully enclosed drawers
- Full extension drawer slides
- Stainless steel handles



DOUBLE SIDE BURNER

Model No. LSB502

- Two burners @12,500 btu per burner
- Includes stainless steel cover
- Blue LED lights activated by grill switch
- Easy to clean sealed burner base



SINGLE SIDE BURNER

Model No. LSB501

- One @12,500 btu burner
- Includes stainless steel cover
- Blue LED light activated by grill switch
- Easy to clean sealed burner base



VINYL COVER FOR BUILT-IN GRILL

Model No. VC600/VC500/VC400



VINYL COVER FOR FREESTANDING GRILL

Model No. VC600F/VC500F/VC400F



INSULATED JACKET

Model No. LIJ600/LIJ500/LIJ400

- Mandatory for grills installed in islands with combustible materials
- Attractive all welded, insulated construction



QUICK DISCONNECT WITH SHUTOFF & FITTINGS

Model No. LQD

- Simple solution for gas connections
- 3/4" ID hose ensures adequate gas supply
- 12' hose includes 3/4" quick disconnect fitting at one end and 3/4" male pipe thread on the other
- Includes manual shut-off valve

SPECIFICATIONS & INSTALLATION

The guides, measurements and dimensions detailed below are designated to assist you with planning your outdoor kitchen.

NOTE: Due to continuing product innovation, specifications are subject to change without notice.

IMPORTANT: Please reference the Care & Use / Installation manual for details on gas plumbing requirements, electrical specifications and the proper installation of your Lynx outdoor kitchen equipment. This manual can be downloaded from the Lynx website at www.lynxgrills.com

THE SEDONA BY LYNX COLLECTION

BUILT-IN GRILL

Model	A	B	C
L400	23.00	10.00	21.25
L500	29.00	10.00	21.25
L600	35.00	10.00	21.25

Measurements in inches.

COMPLEMENTARY PRODUCTS

Model	A	B	C
LSB501*	11.00	4.00	16.00
LSB502*	21.00	4.00	16.00
LDR424	22.00	19.00	-
LDR530	28.25	19.00	-
LDR636	33.75	19.00	-
LSA530	28.25	19.00	20.00
LSA636	33.75	19.00	20.00
LUD517	17.25	12.75	20.00
L500REF	21.50	34.00	24.50

BUILT-IN GRILL WITH INSULATING JACKET

Model	A	B	C
LIJ400	30.00	11.62	23.25
LIJ500	36.00	11.62	23.25
LIJ600	42.00	11.62	23.25

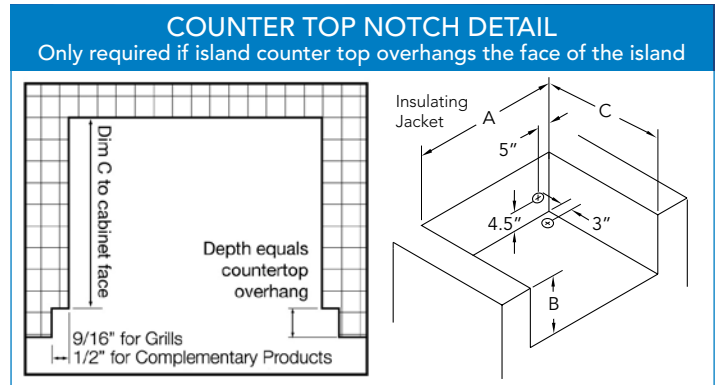

Note: Insulating jacket required for all grills installed into a combustible enclosure.

Note: For Natural Gas grills, Lynx recommends using 3/4" gas lines.

Note: Side burners may be rotated 90 degrees. See installation manuals for details.

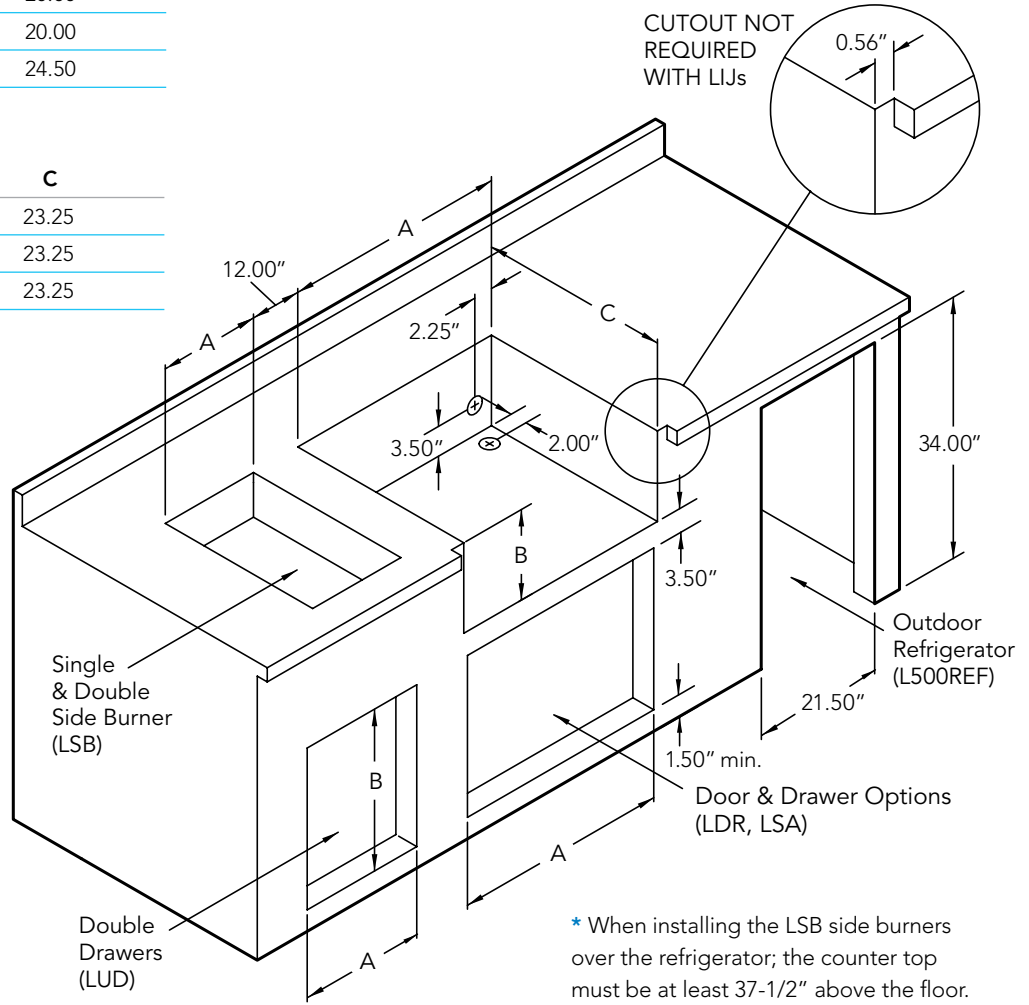
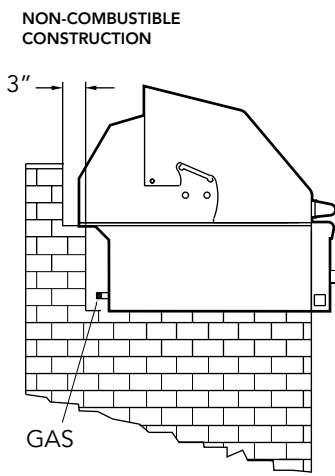

* When installing the LSB side burners over the refrigerator; the counter top must be at least 37-1/2" above the floor.