



SU1

S 1

- Motor: **600 cfm**
Aluminium die-cast motor housing
- Pressure: **480 Pa**
- Noise level: **63 dBA/4.9 sones**



- Lighting: 2x20W halogen lamps



- Control panel: 4 speed push-button + timer + light switch

- grease filter: anodized aluminium (5+1 layers)
: stainless steel baffle filter optional – LBR

- Stainless steel: AISI 430

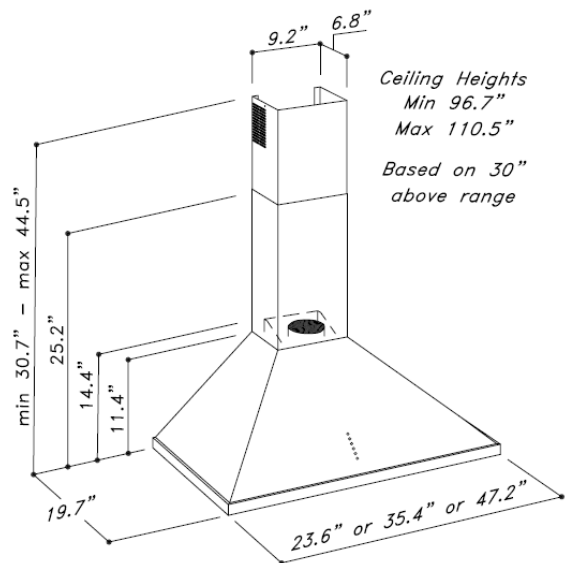

Sirius