

## STFABUCR-1

### 50's Retro style

Approx 24" Pre-finished Dishwasher with 50'S Retro Style handle, Cream

EAN13: 8017709262662

Full-size tub

Hidden stainless steel electronic control panel

Self-balancing door

10 wash cycles including crystal washing, economy cycle and speed (27min)

Sanitation

Condenser drying

Stainless steel tub and filter

Concealed heating element

Half-load

Delay timer (up to 9 hours)

5 temperatures: 100°F, 113°F, 122°F, 149°F, 158°F

#### Orbital Wash System

Complete Water Leak Protection System

#### 13 place setting

Enameled steel baskets

Adjustable upper basket to accommodate plates up to 13 ¾" in diameter

2 cutlery baskets

With third cutlery basket

#### Third upper basket for cutlery: FlexiDuo

4 flip-down spike rails on lower basket

2 glass support racks in upper basket

Lower basket with double foldable rack

Noise level: 43dB (A)

Energy Star-rated

Height leveling legs

Voltage rating: 115V - 60Hz

Nominal power: 13Amps - 1,800W

Voltage 110-120V: Frequency 60Hz.

Water usage: normal/short cycle: 3.54/1.72 gal.



## Functions



## Options

- **KIT6FIL** - 2" decorative fill strip.

## Versions

- **STFABUBL-1** - Black
- **STFABUPB-1** - Pastel blue
- **STFABURD-1** - Red

• **STFABUWH** - White

**SMEG U.S.A. INC.  
A&D BUILDING  
150 EAST 58th STREET, 7th FLOOR  
NEW YORK, NY, 10155  
Tel. +1 212 265 5378  
Fax +1 212 265 5945**



## STFABUCR-1

50's Retro style

built-in  
24"  
cream  
orbital



---

### Energy Star and ISO14001 Certified:

The Smeg production process is carefully managed in order to keep the impact upon the environment as low as possible. The process is checked and certified by Independent International bodies IQNET and CISQ (Smeg complies with the standard ISO14001). All Smeg dishwashers are ENERGY STAR qualified. Energy efficiency is important to Smeg and our technicians are constantly working to keep the energy, and water, consumption of each dishwasher as low as possible. ENERGY STAR certified products use less water than conventional dishwashers, and approximately 40% less energy than the federal minimum standard for energy consumption. By choosing an ENERGY STAR certified product you are helping to preserve the environment without compromising on product quality or performance.



**SMEG U.S.A. INC.**  
**A&D BUILDING**  
**150 EAST 58th STREET, 7th FLOOR**  
**NEW YORK, NY, 10155**  
**Tel. +1 212 265 5378**  
**Fax +1 212 265 5945**



# STFABUCR-1

50's Retro style

built-in  
24"  
cream  
orbital

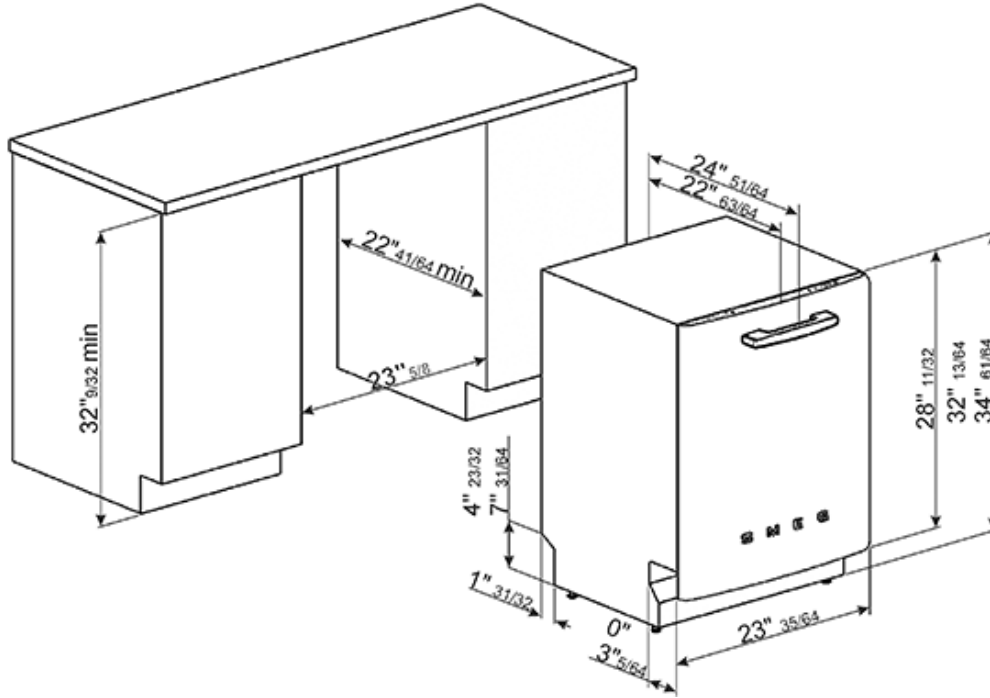

SMEG U.S.A. INC.  
A&D BUILDING  
150 EAST 58th STREET, 7th FLOOR  
NEW YORK, NY, 10155  
Tel. +1 212 265 5378  
Fax +1 212 265 5945