

- Signature SAPPHIRE Blue interior
- Full wrapped stainless-steel exterior
- 2 full extension stainless steel lined drawers
- Multifunction capacitive touch electronic control
- Temperature range: 34°F to 65°F
- Fan assisted cooling system allows for even temperatures, quicker cool down times, and added efficiency
- Full LED theater lighting
- Adaptable stainless steel dividers in each drawer allows customization of drawer space
- Stainless model includes 1" diameter stainless steel handles with faceted standoffs (22" Length)
- Panel Ready model requires ¾" custom door panel and handle
- 4 independent adaptable leveling legs
- Adaptable grille accepts an integrated toe-kick and allows front/back and up/down alignment with adjacent cabinetry and toe kick/plinth
- Automatic defrost
- Lock model available



Stainless



Panel Ready



Stainless with lock

**Model Details**

Model	Lock	Finish	Description	Shipping Weight	MAP
SRD24-SS	No	Stainless Steel	24" Indoor Refrigerator Drawers	157 lbs	\$2399
SRD24-SS-L	Yes	Stainless Steel	24" Indoor Refrigerator Drawers	157 lbs	\$2449
SRD24-PR	No	Panel Ready	24" Indoor Refrigerator Drawers	154 lbs	\$2249

Dimensions/Weight	Detail
Product Depth	23 ¼"
Product Height	34" - 35"
Product Width	23 7/8"
Product Weight	127 lbs
Product Volume	4.6 cu ft
Shipping Dimensions	26 ¾" x 27 ½" x 36 ¾"
Shipping Weight	157 lbs

Integration/Panel Information*	Detail
Panel Height	2 Panels: 14 7/8" each
Panel Thickness	¾" - 20 mm
Panel Width	23 5/8"

\*Refer to manual for all panel dimensions and installation instructions



Model	Details
Control Type	Electronic Capacitive Touch with OLED Screen
Indoor or Outdoor	Indoor
Built-in Installation	Inset, Frameless / Overlay and Framed Cabinet Styles
Refrigerant Type	R600

Electrical	Details
Electrical Requirements	115 V / 60 Hz
Volt Range	104 V ~ 127 V
Maximum Amp Fuse	15 amp
Amps Running	0.7 amps

Approvals - Certifications	Details
ETL Residential / Commercial	Yes
ETL Sanitation	Yes
Star K	Yes

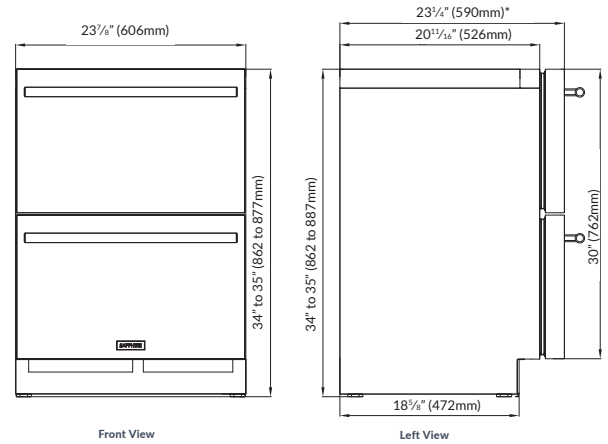
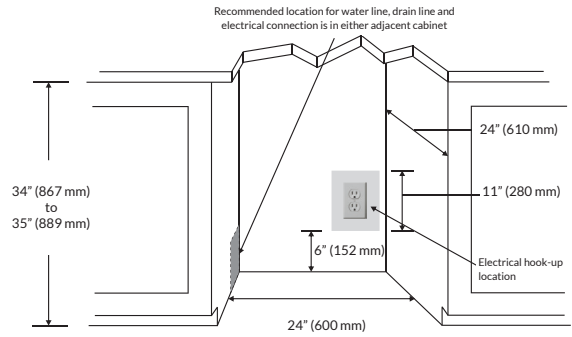

\*Dimensions are the same for Panel Ready unit when 3/4" panel applied

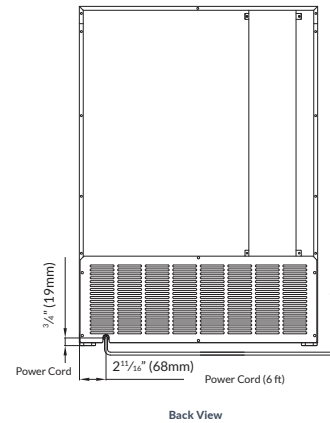

### Limited Warranty

The limited warranty covers any defects in material or workmanship under normal use during the warranty period. Limited warranty covers two-year parts and labor and five-year sealed system parts. During the warranty period, Sapphire will repair or replace, at no charge, products or parts of a product that proves defective because of improper material or workmanship, under normal use and maintenance. See complete warranty for details.

### Contact Us

Customer Service: 1.866.754.6672 | Hours: 9am - 5pm

SAPPHIRE Appliances | The Legacy Companies  
 3355 Enterprise Avenue, Suite 160, Weston, FL 33331  
 email@sapphireappliances.com | SapphireAppliances.com

All specifications are subject to change without notice.