

EMPIRE

INTRODUCES...

**NEW**  
Now Available!

# Premium Quality 16 Gauge Stainless Steel Kitchen Sink

Model **SP-19C**

**GRID &  
STRAINER  
INCLUDED**



List Price  
**\$695**  
incl. grid & strainer

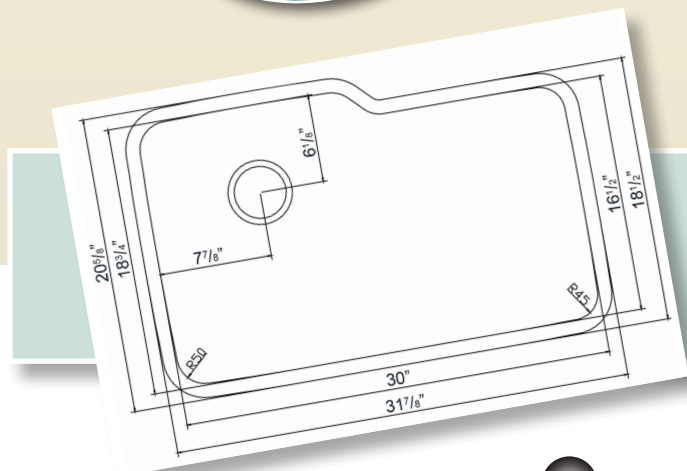

Overall dimensions:  
31<sup>7</sup>/<sub>8</sub>"(L) x 20<sup>5</sup>/<sub>8</sub>"(W) x 10"(D)

\* Available now on the West Coast.  
Available on the East Coast January 2012.

**EMPIRE**  
INDUSTRIES INC.

Tel: 1-800-631-0223 • Fax: 1-800-367-4738 • [www.empire-industries.com](http://www.empire-industries.com)