



F R I E D R I C H

SPLIT TYPE
ROOM AIR CONDITIONER
WALL WOUNTED TYPE

SERVICE MANUAL

Indoor unit	Outdoor unit
MW24C3G	MR24C3G



800-570-3355

CONTENTS

SPECIFICATIONS	1
DIMENSIONS	2
REFRIGERANT SYSTEM DIAGRAM	3
CIRCUIT DIAGRAM	4
INDOOR PCB CIRCUIT DIAGRAM	5
OUTDOOR PCB CIRCUIT DIAGRAM	8
ERROR DETECTION	10
PARTS (indoor unit)	12
PARTS (outdoor unit)	16
ACCESSORIES	19

SPECIFICATIONS

ELECTRICAL DATA

INDOOR UNIT	MW24C3G
OUTDOOR UNIT	MR24C3G
COOLING CAPACITY	24,000 BTU, 7.03 kW
POWER SOURCE	208 / 230 V
FREQUENCY	60 Hz
RUNNING CURRENT	10.5 A
INPUT WATTS	2.4 kW
E.E.R.	10.0 BTU/hW, 2.93 kW/kW
MOISTURE REMOVAL	6.3 Pt/h, 3.0 L/hr
AIR CIRCULATION HIGH	659 cfm, 1,120 m3/hr
MAXIMUM CURRENT	11.5 A

FAN MOTOR

POWER SOURCE	230 V	
INDOOR UNIT	High	1,480 r.p.m.
	Medium	1,220 r.p.m.
	Low	1020 r.p.m.
	Quiet	900 r.p.m.
OUTDOOR UNIT	1,100 r.p.m.	

NOISE LEVEL

INDOOR UNIT	High	48 dB
	Medium	42 dB
	Low	37 dB
	Quiet	33 dB
OUTDOOR UNIT	56 dB	

COMPRESSOR AND REFRIGERANT

TYPE	Hermetic type, 4 pole, DC inverter motor, Scroll	
DISCRIMINATION	DA150A1F-20NA	
WEIGHT (with oil)	22 lbs, 10.0 kg	
REFRIGERANT TYPE	R410A	
PRECHARGED REFRIGERANT	2 lbs 14 oz, 1,300 g	
FULL CHARGE	Pipe length 49 ft, 15 m	2 lbs 14 oz, 1,300 g
	66 ft, 20 m	3 lbs 1 oz, 1,400 g
	82 ft, 25 m	3 lbs 5 oz, 1,500 g
	98 ft, 30 m	3 lbs 8 oz, 1,600 g
ADDITIONAL CHARGE	0.21 oz/ft, 20 g/m	
MAXIMUM HEIGHT DIFFERENCE	66 ft, 20 m	

DIMENSIONS

INDOOR UNIT	H x W x D	12-5/8 x 39-1/4 x 9 inch 320 x 998 x 228 mm
OUTDOOR UNIT	H x W x D	24-13/32 x 31-3/32 x 11-13/32 inch, 620 x 790 x 290 mm

WEIGHT

INDOOR UNIT	Shipping / Net	40 lbs / 31 lbs 18 kg / 14 kg
OUTDOOR UNIT	Shipping / Net	97 lbs / 88 lbs 44 kg / 40 kg

DIMENSIONS

Unit : inch (mm)

INDOOR UNIT

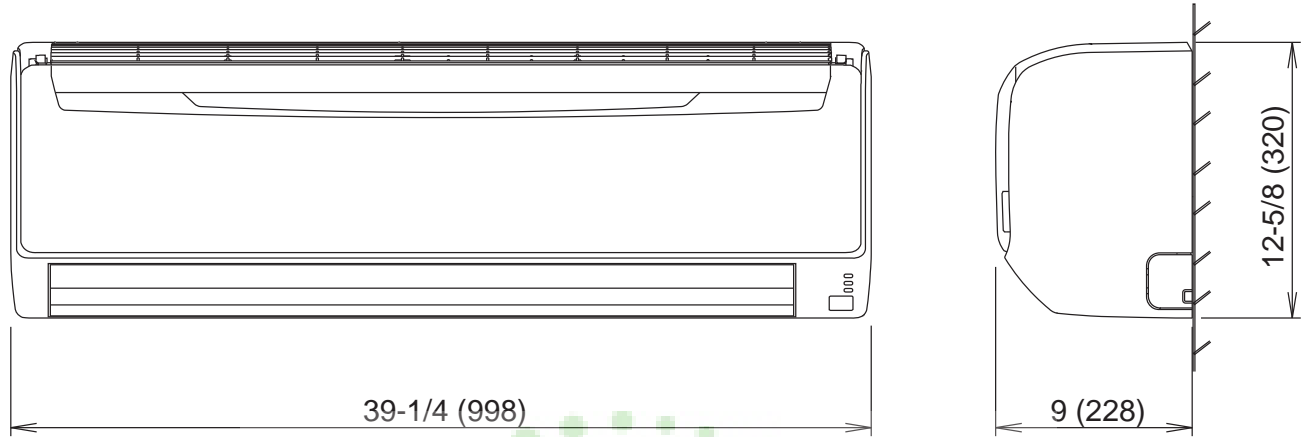

Drain hose length : $26\frac{3}{8}$ inch (670 mm)

OUTDOOR UNIT

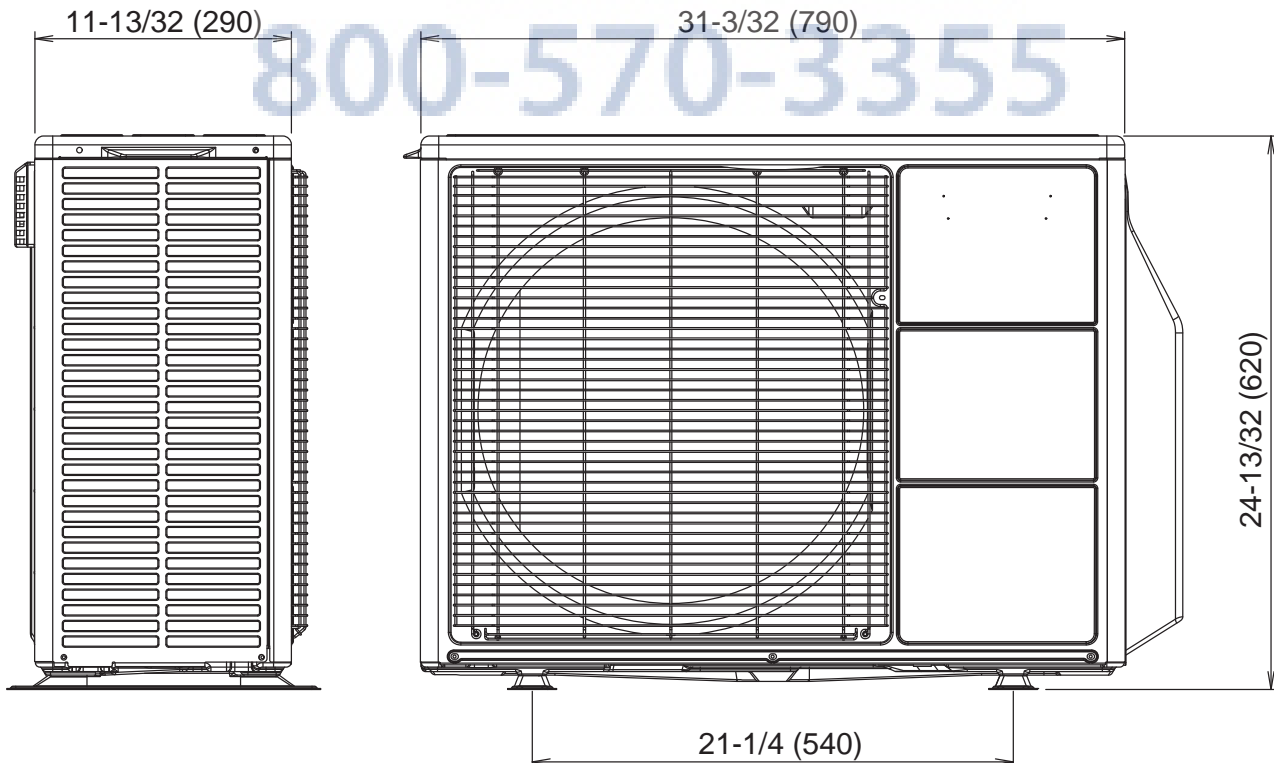

REFRIGERANT SYSTEM DIAGRAM

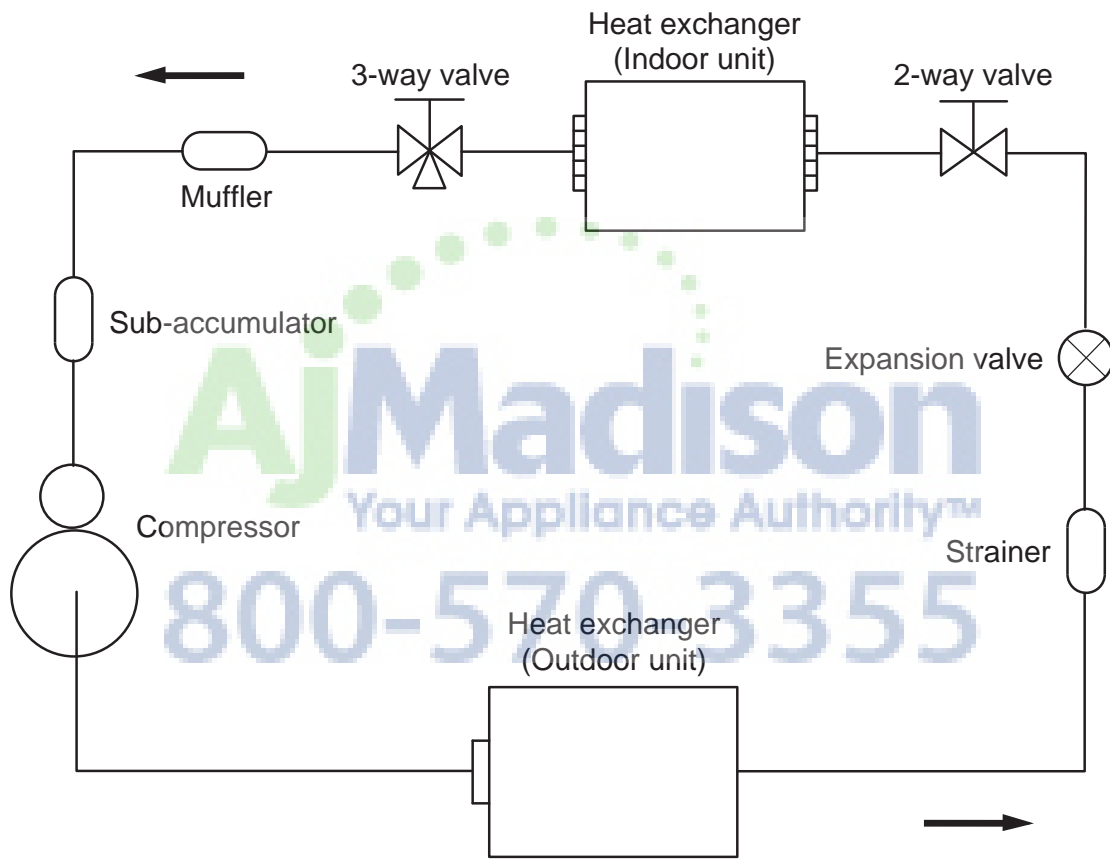

→
Refrigerant direction

Refrigerant pipe diameter
 Liquid : 1/4" (6.35 mm)
 Gas : 5/8" (15.88 mm)

INDOOR PCB CIRCUIT DIAGRAM

OUTDOOR UNIT

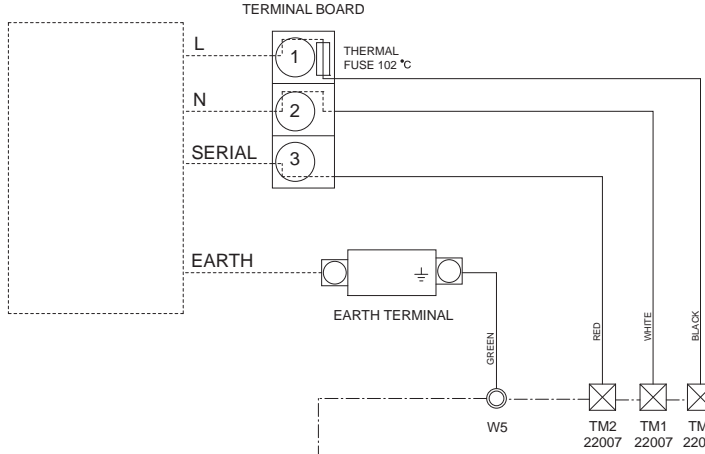

CONTROL UNIT
EZ-0107WSE

INDICATOR PCB ASSEMBLY
K05CY-0500HSE-D0

CONTROLLER PCB ASSEMBLY
(MAIN PCB)
K08CX-1001WSE-C1

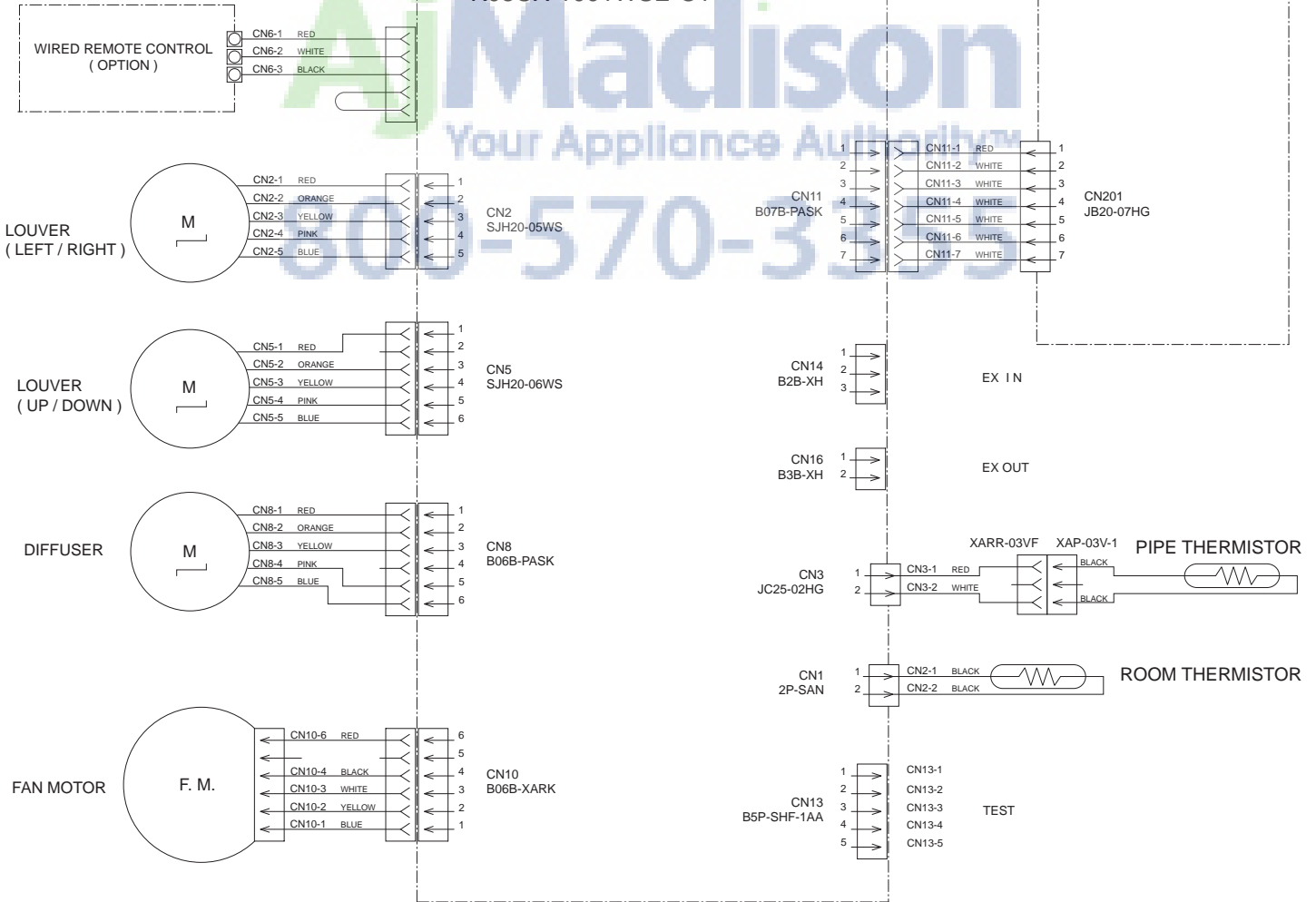

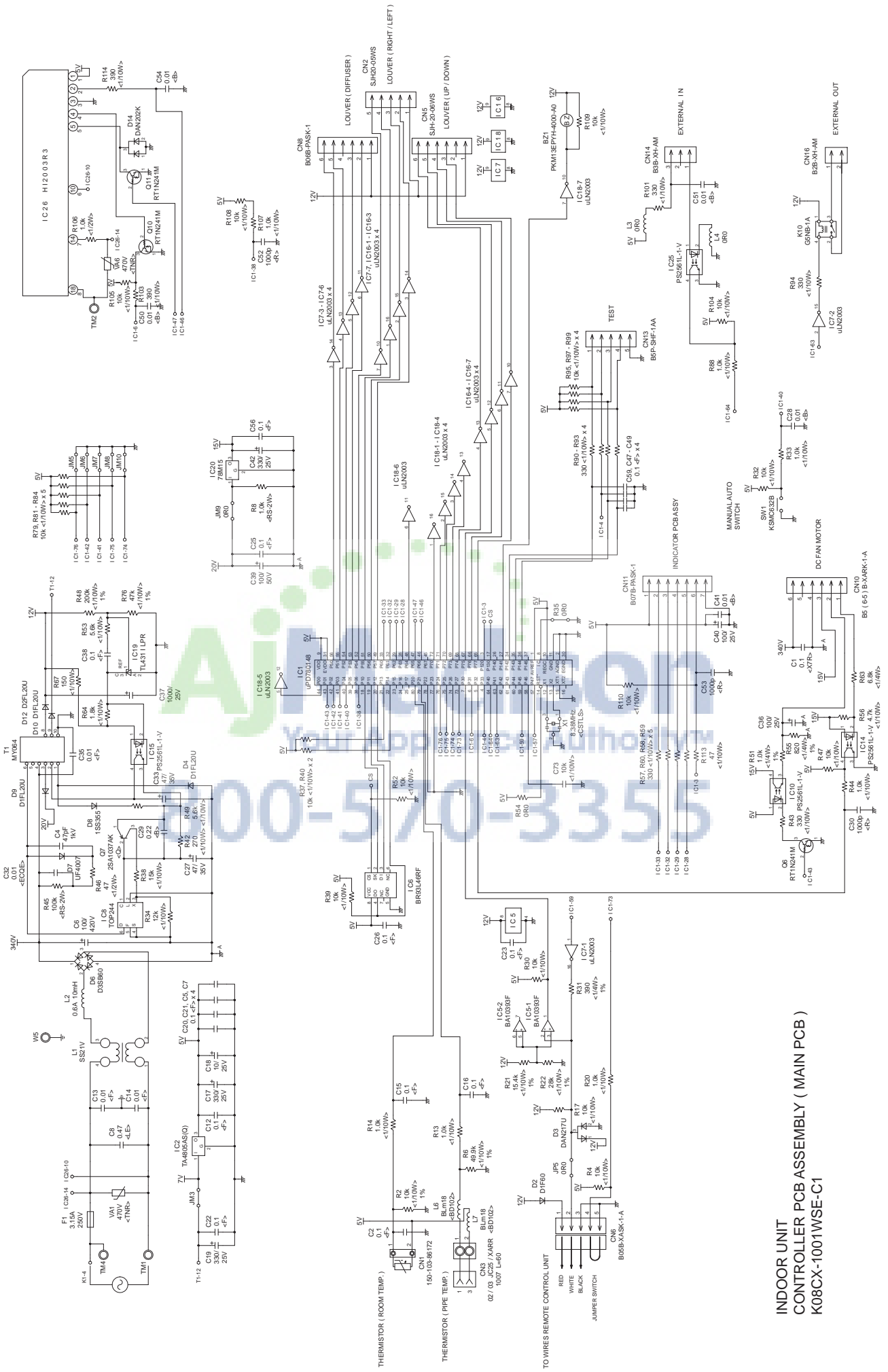

**INDOOR UNIT
CONTROLLER PCB ASSEMBLY (MAIN PCB)
K08CX-1001WSE-C1**

INDOOR UNIT
 INDICATOR PCB ASSEMBLY
 K05CY-0500HSE-D0

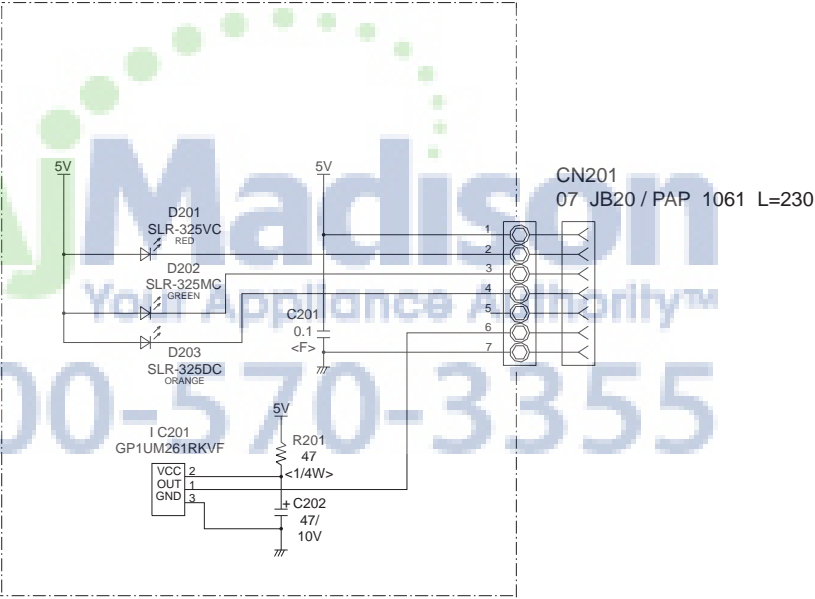

OUTDOOR PCB CIRCUIT DIAGRAM

INVERTER ASSEMBLY EZ-0101WUE

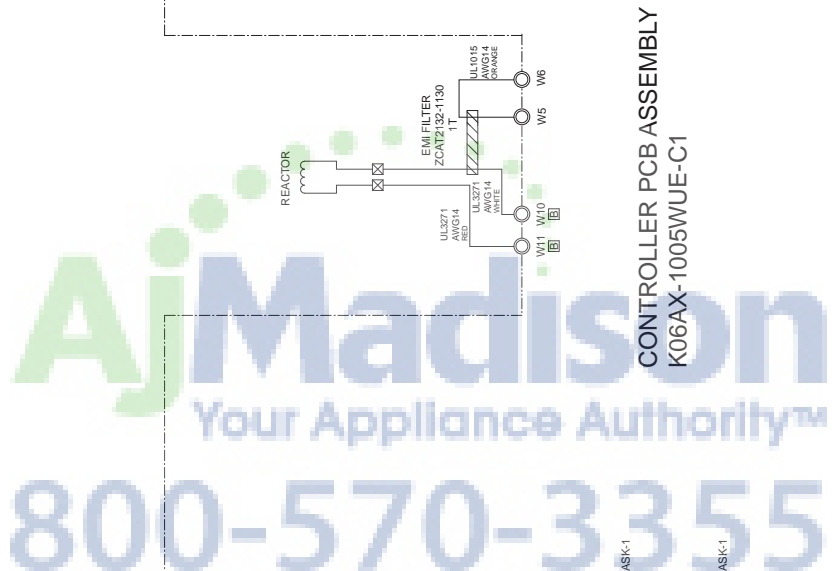
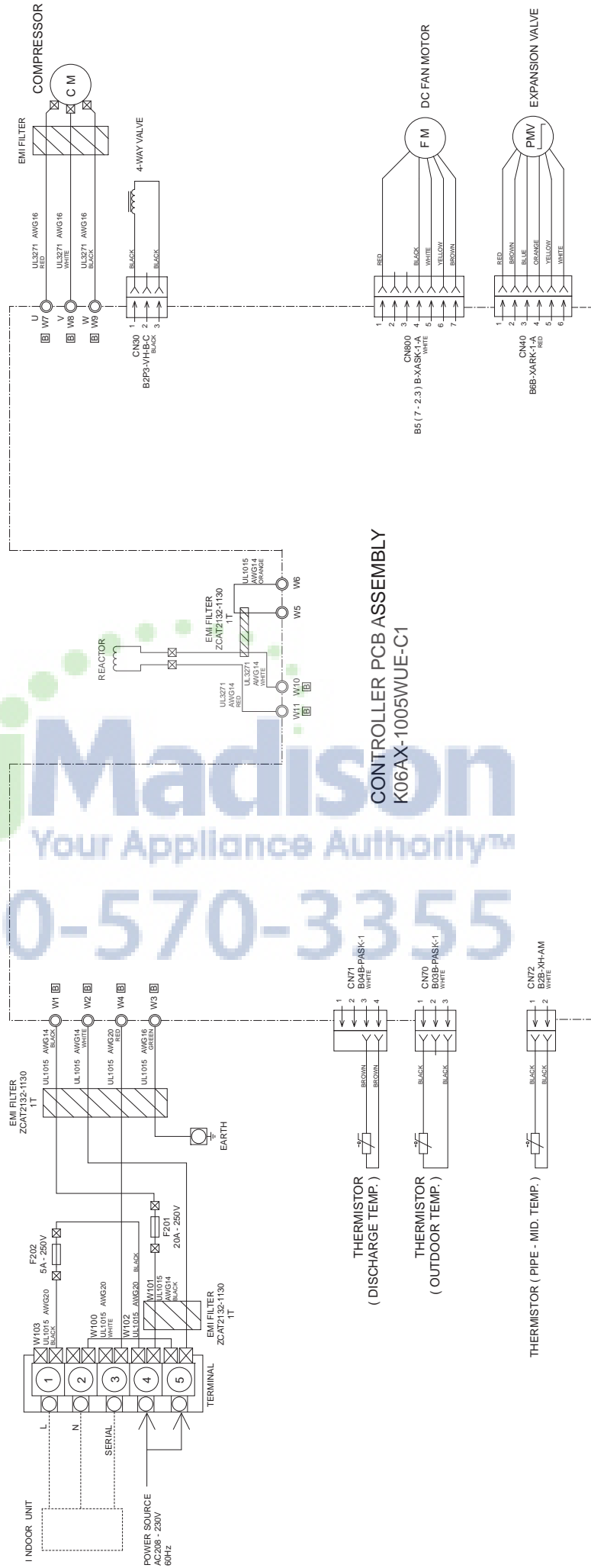

CONTROLLER PCB ASSEMBLY
K06AX-1005WUE-C1

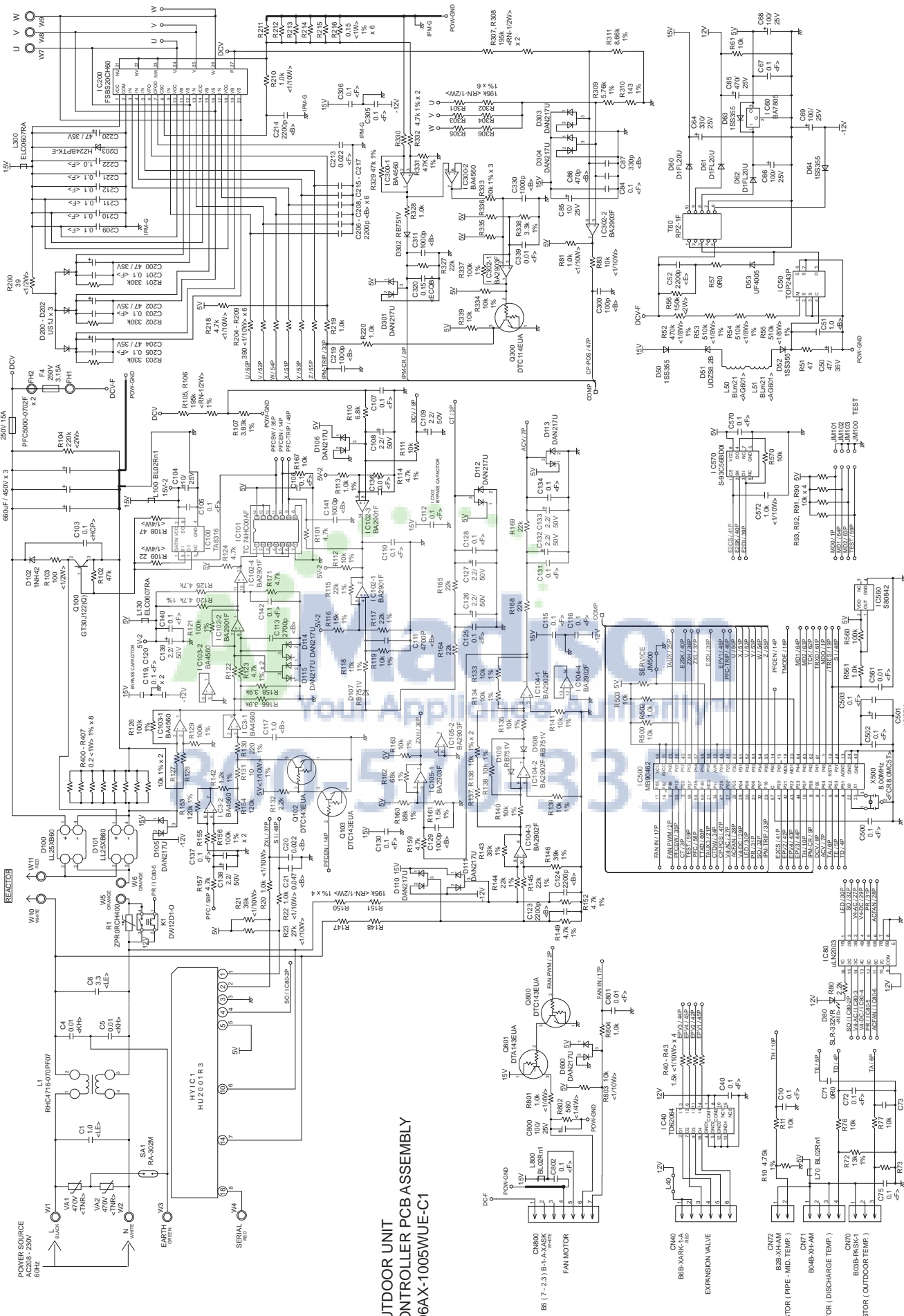

**OUTDOOR UNIT
CONTROLLER PCB ASSEMBLY
K06AX-1005WUE-C1**

ERROR DETECTION

Error	Display		Error
	Operation LED	Timer LED	
Serial signal error	Off	2 flash	Serial signal (reverse) error, at operation start up
		3 flash	Serial signal (reverse) error, during operation
		4 flash	Serial signal (forward) error, at operation start up
		5 flash	Serial signal (forward) error, during operation
		8 flash	Wired remote controller error
Indoor unit thermistor error	2 flash	2 flash	Indoor temperature thermistor open / short
		3 flash	Heat exchanger middle thermistor open / short
Outdoor unit thermistor error	3 flash	2 flash	Discharge thermistor open / short
		3 flash	Heat exchanger thermistor open
		4 flash	Outdoor temperature thermistor open / short
Indoor unit control error	4 flash	2 flash	Forced automatic SW welded
		3 flash	Main relay welded
		4 flash	Power interruption error
		7 flash	VDD permanent stop protection
		8 flash	reverse VDD permanent stop protection
Outdoor unit control error	5 flash	2 flash	Current trip error
		3 flash	CT abnormal
		5 flash	Compressor location detection error
		6 flash	Outdoor unit fan drive system abnormal
Indoor fan motor error	6 flash	2 flash	Abnormal lock
		3 flash	Abnormal rotation
Refrigerant cycle error	7 flash	2 flash	Discharge Temperature abnormal
		3 flash	Cooling high pressure abnormal rise
Optional function error	8 flash	4 flash	PFC circuit error
Model information error	0.1 sec on/off	0.1 sec on/off	Model information error

OUTDOOR UNIT

LED	ERROR
on	Discharge temperature abnormal
5.0 second on / 5.0 second off	Fan abnormal
5.0 second on / 0.1 second off	AF PAM voltage abnormal
2.0 second on / 2.0 second off	CT abnormal
0.5 second on / 0.5 second off	Trip
0.1 second on / 2.0 second off	Compressor location abnormal
0.1 second on / 0.1 second off	Thermistor abnormal

PARTS
INDOOR UNIT

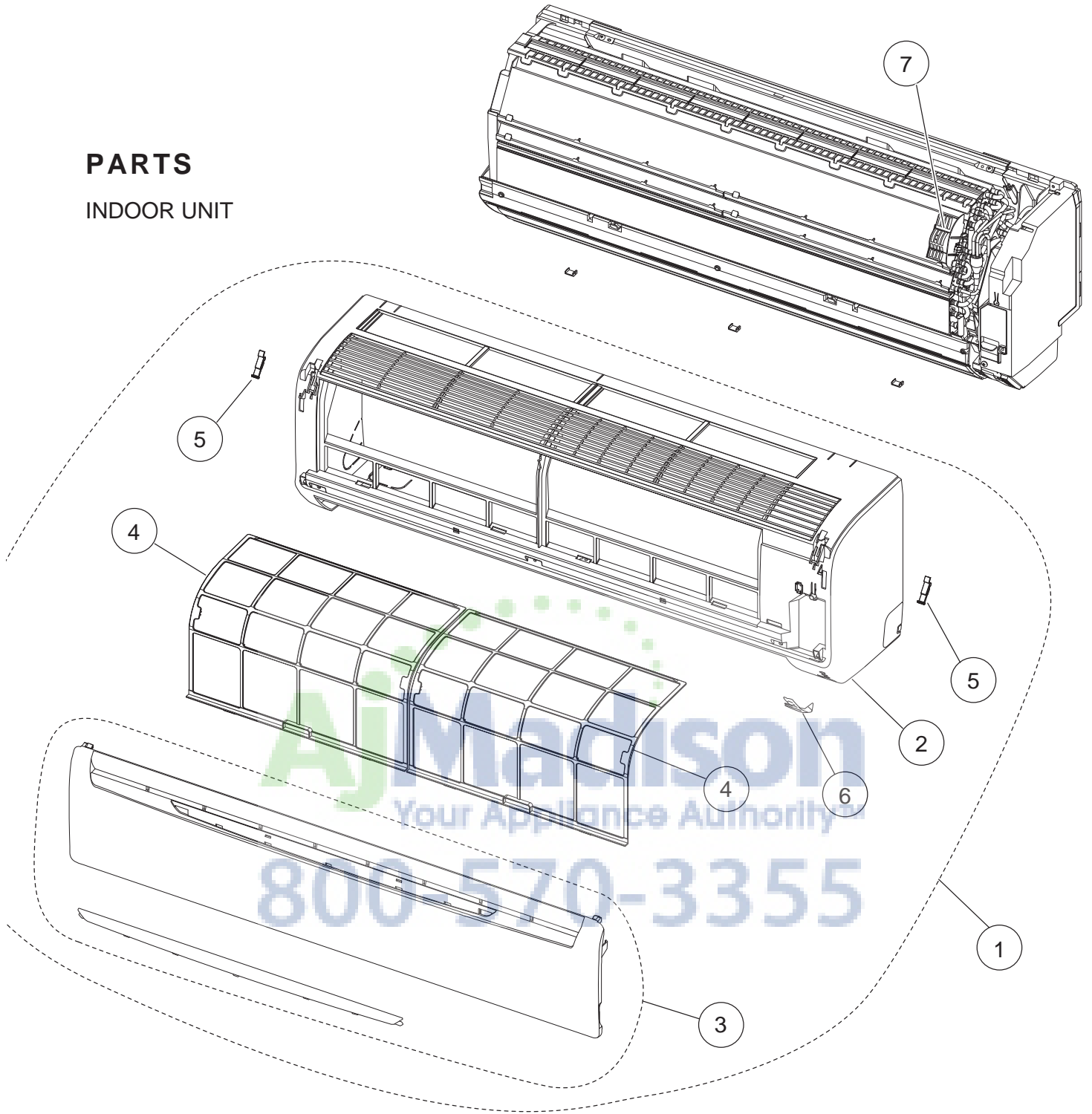

Ref	Description	Part number
1	Front Panel Total Assy	9315335081
2	Front Panel	9314991028
3	Intake Grille Assy	9315336064
4	Air Filter	9315014016
5	Clamper Grille	9306755010
6	Receiver Window	9315010018
7	Room Thermistor Holder	9315252012
--	Remote Control	9315027160
--	Remote Control Holder	9305642045

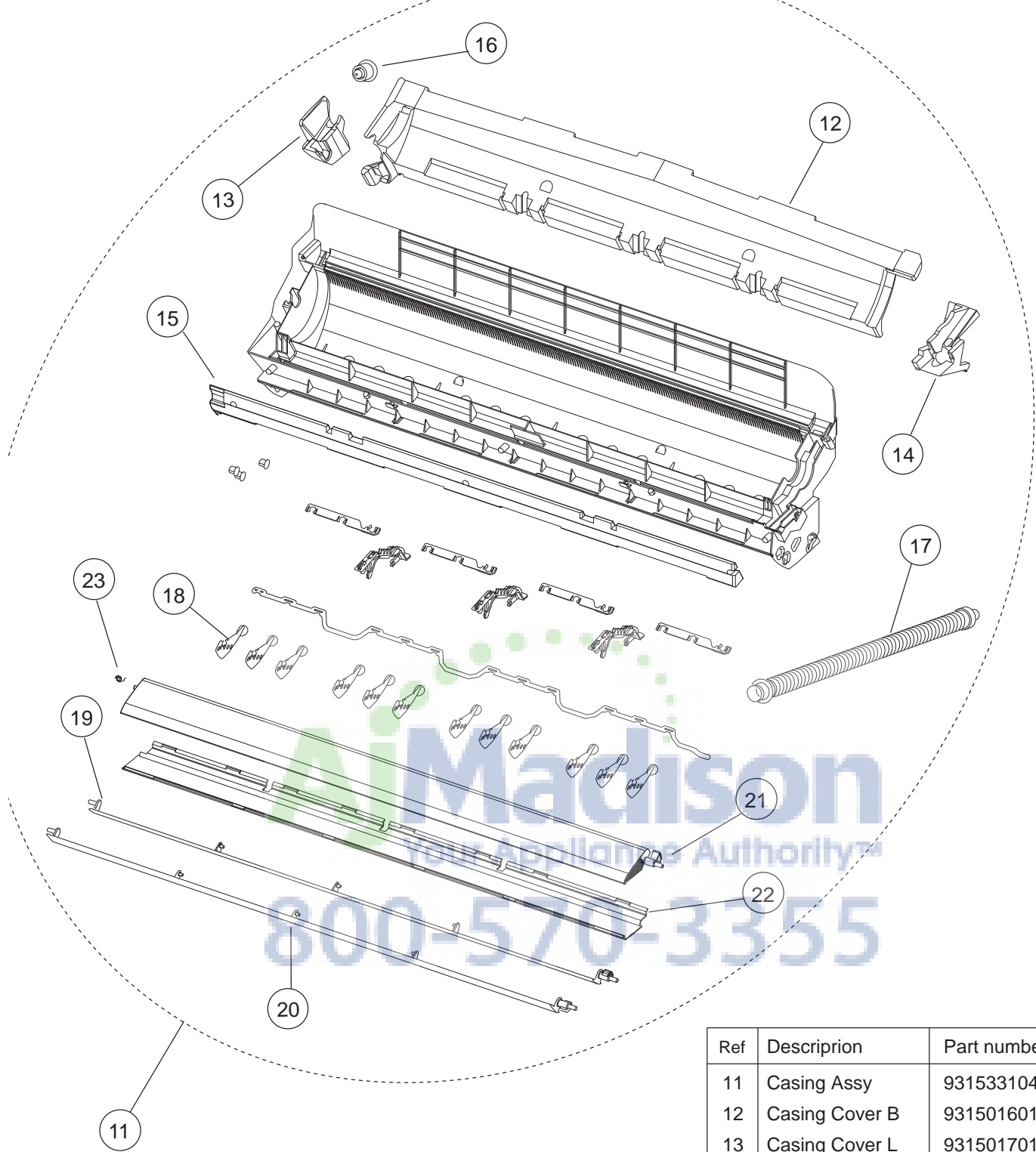

INDOOR UNIT

Ref	Description	Part number
11	Casing Assy	9315331045
12	Casing Cover B	9315016010
13	Casing Cover L	9315017017
14	Casing Cover R	9315018014
15	Casing Cover F	9315019011
16	Drain Cap	9367677009
17	Drain Hose Assy	9315769015
18	R and L Louver	9311997016
19	Louver U	9315000019
20	Louver Z	9315001016
21	Diffuser U	9315002013
22	Diffuser Z	9315003010
23	Spring C	9314142017
--	Fan Guard	9305751051
--	Fan Guard Holder R	9315814012
--	Fan Guard Holder L	9315815019

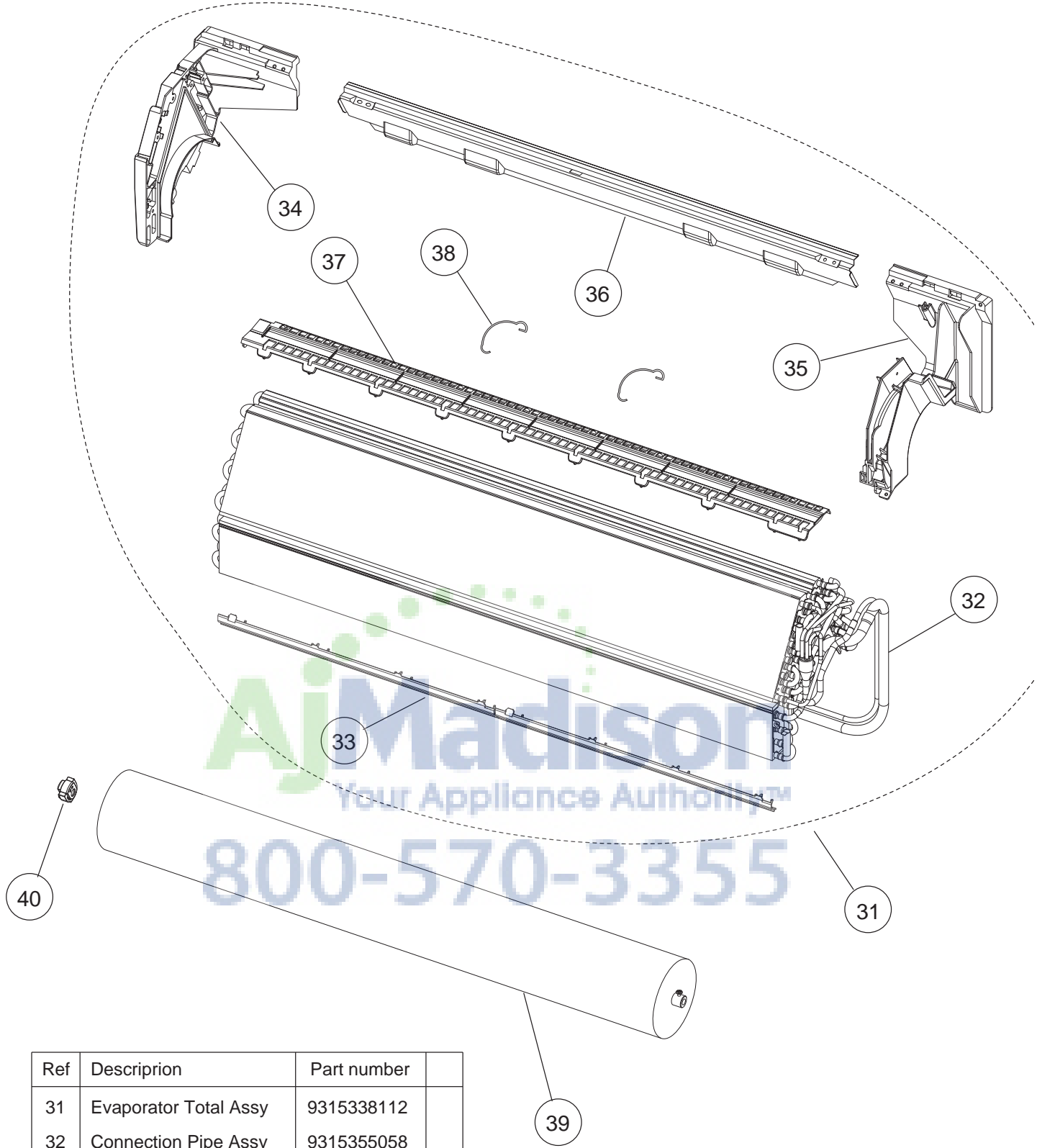

INDOOR UNIT

Ref	Description	Part number
31	Evaporator Total Assy	9315338112
32	Connection Pipe Assy	9315355058
33	Water Seal	9315251015
34	Evaporater Holder R	9314994012
35	Evaporater Holder L	9314995019
36	Rear Bracket	9315022011
37	Filter Guide	9315013019
38	Filter Guard	9315411013
39	Crossflow Fan Assy	9315024015
40	Bearing C Assy	9306628017

INDOOR UNIT

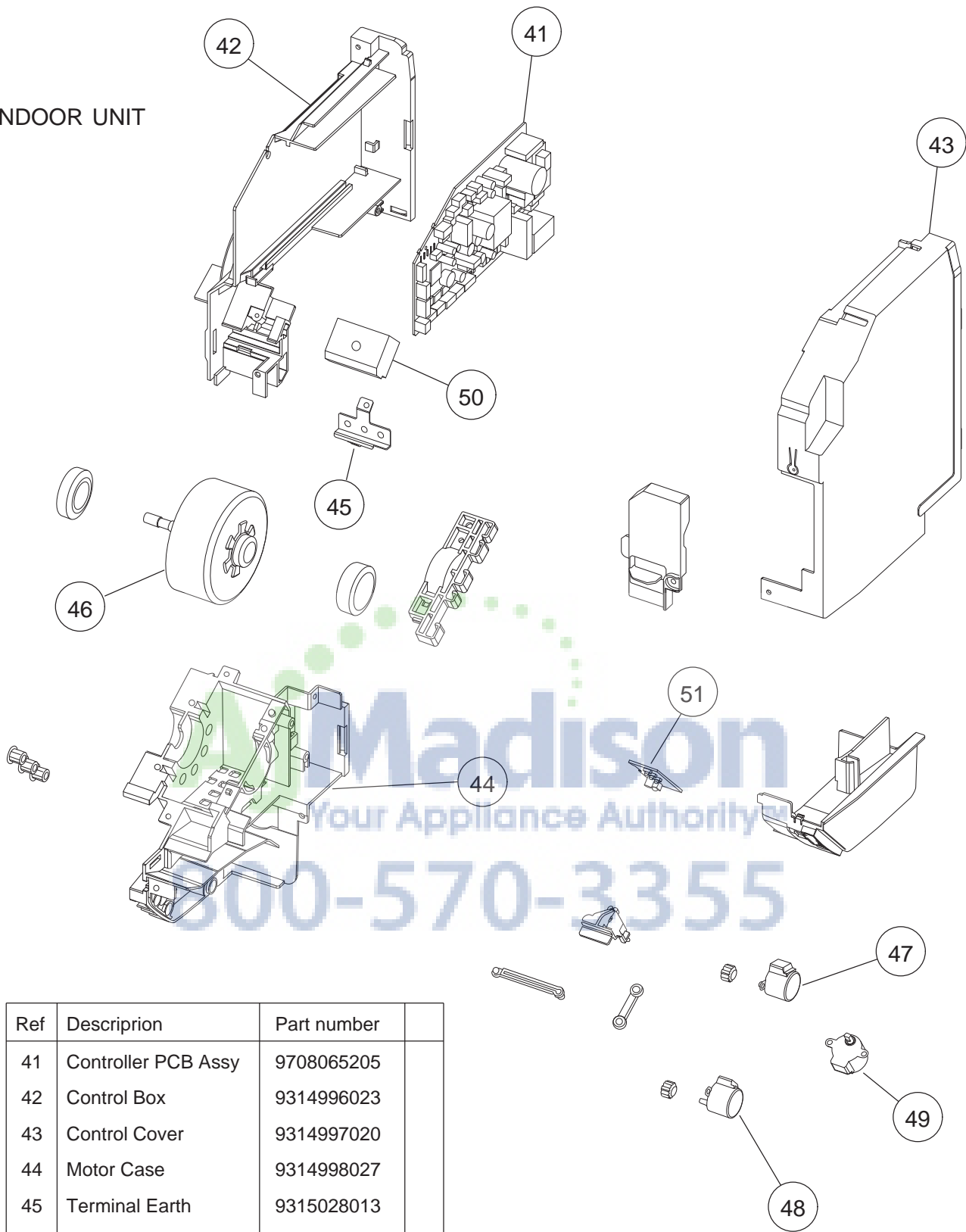

Ref	Description	Part number	
41	Controller PCB Assy	9708065205	
42	Control Box	9314996023	
43	Control Cover	9314997020	
44	Motor Case	9314998027	
45	Terminal Earth	9315028013	
46	DC Brushless Motor	9602784004	
47	Motor, Step	9900384029	
48	Motor, Step	9900384036	
49	Motor, Step	9900139063	
50	Terminal	9900447014	
51	Indicator PCB Assy	9707210019	
--	Pipe Thermistor	9900551018	

PARTS

OUTDOOR UNIT

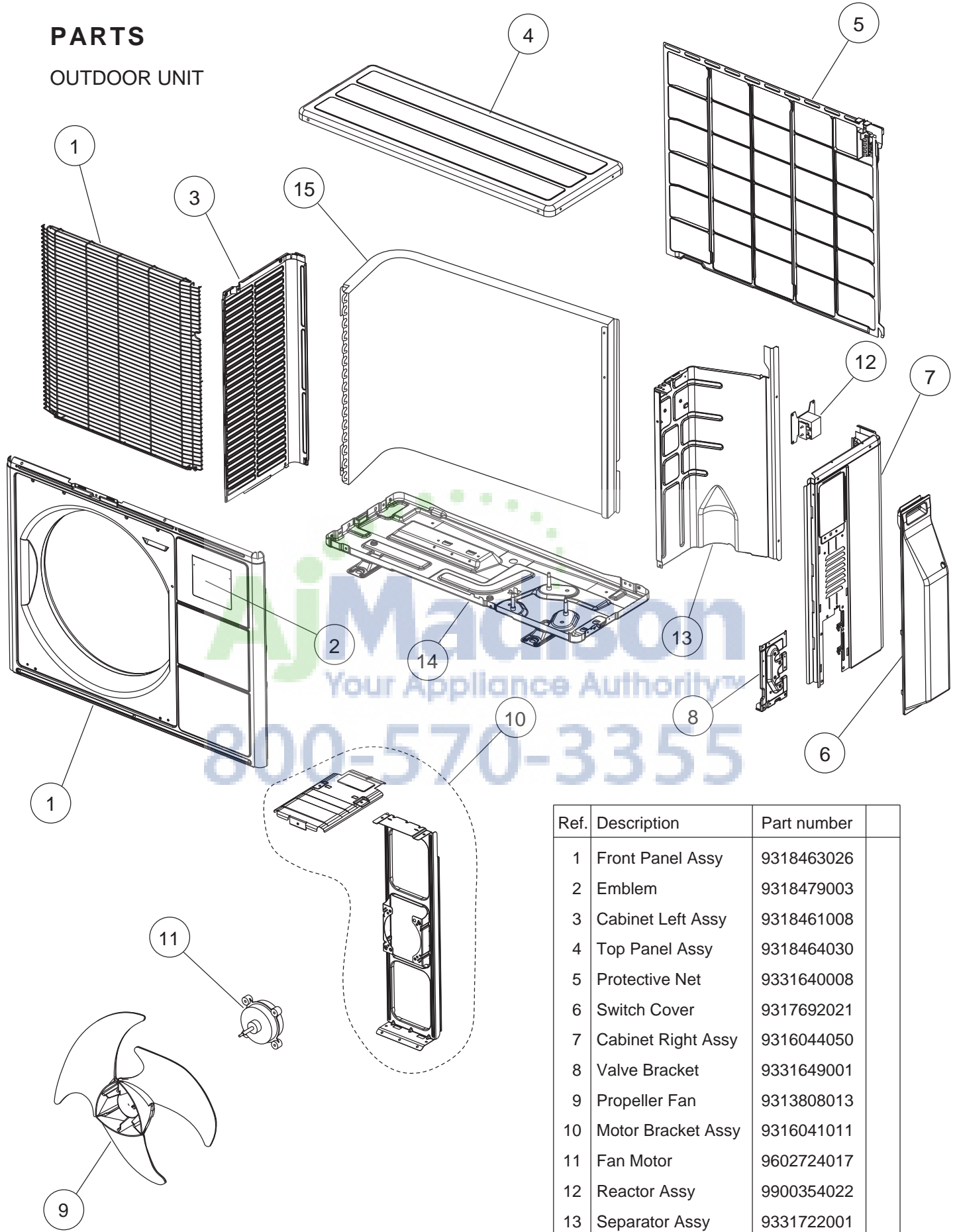

Ref.	Description	Part number
1	Front Panel Assy	9318463026
2	Emblem	9318479003
3	Cabinet Left Assy	9318461008
4	Top Panel Assy	9318464030
5	Protective Net	9331640008
6	Switch Cover	9317692021
7	Cabinet Right Assy	9316044050
8	Valve Bracket	9331649001
9	Propeller Fan	9313808013
10	Motor Bracket Assy	9316041011
11	Fan Motor	9602724017
12	Reactor Assy	9900354022
13	Separator Assy	9331722001
14	Base Assy	9316885028
15	Condencer Total Assy	9331660013

OUTDOOR UNIT

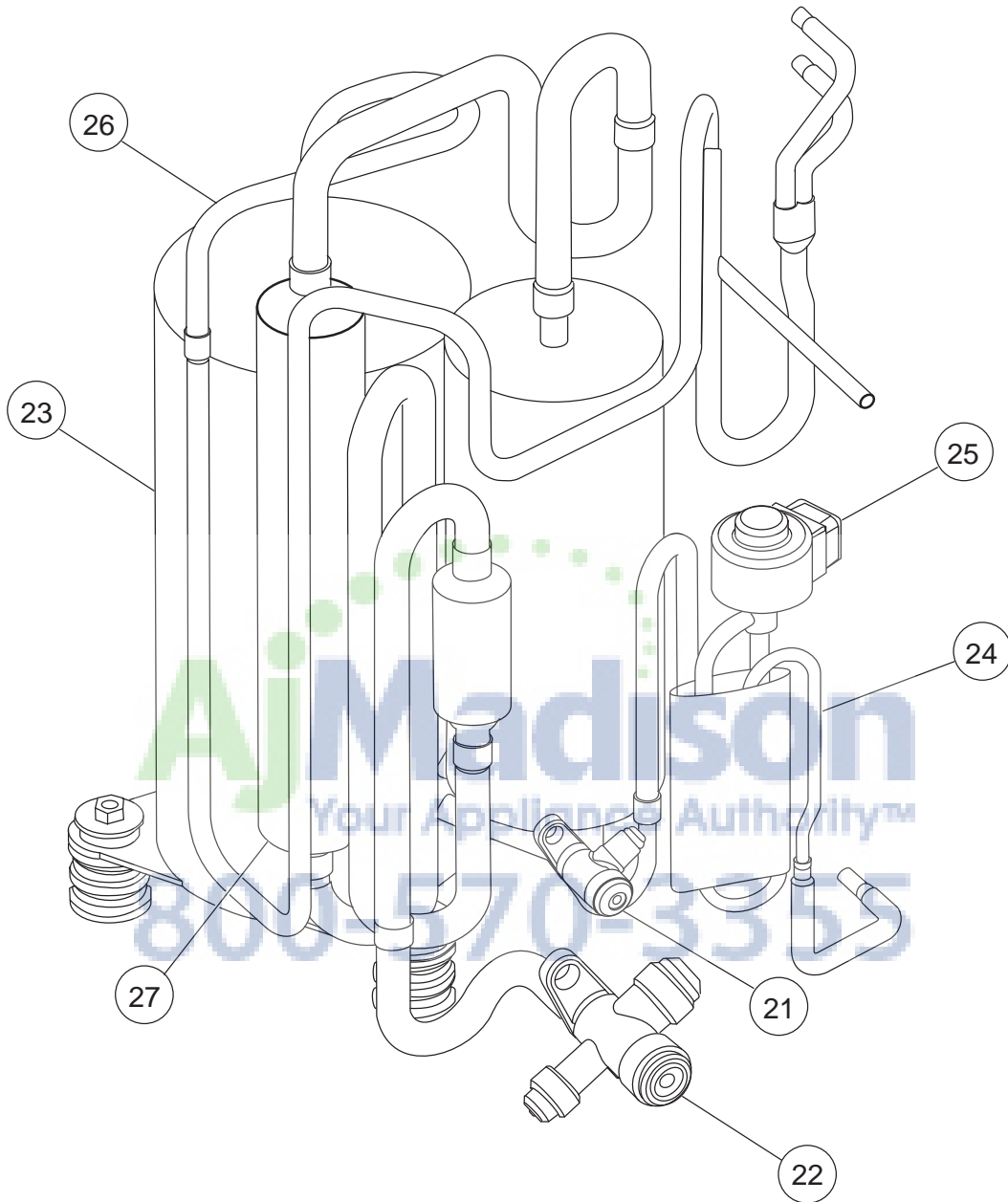

Ref	Description	Parts number
21	2-way Valve Assy	9314554018
22	3-way Valve Assy	9331674003
23	Compressor Assy	9315297044
24	Pulse Motor Valve Assy	9331647007
25	Expansion Valve Coil	9900057039
26	Discharge Pipe Assy	9331643009
27	Suction Pipe Assy	9331642002

OUTDOOR UNIT

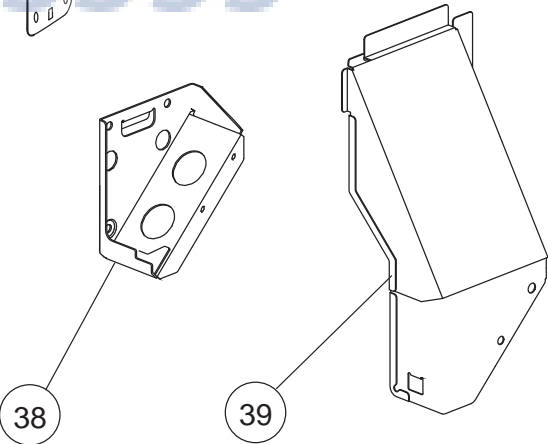
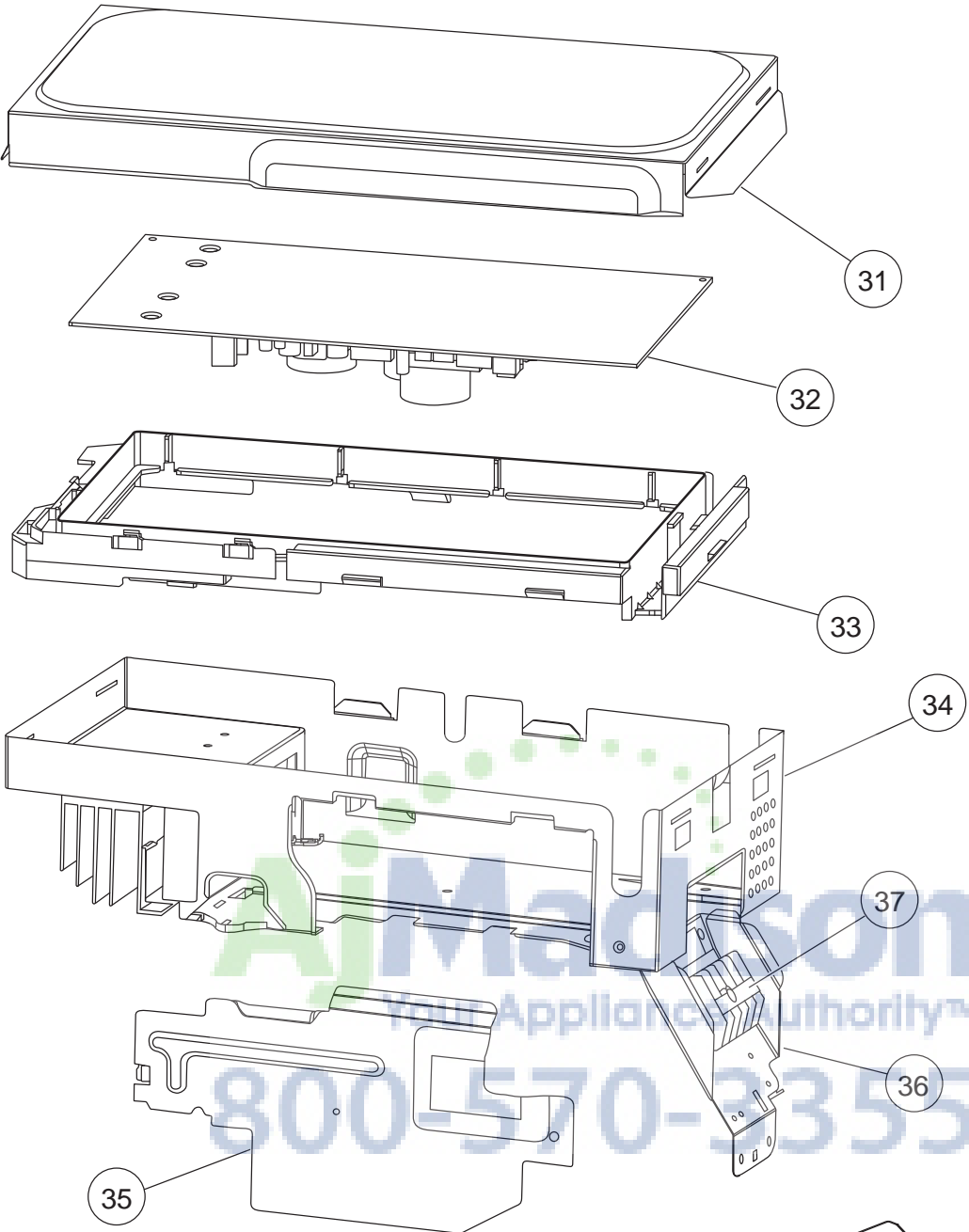

Ref	Description	Parts number
31	Case Cover	9309913011
32	PCB Assy	9707427455
33	PCB Holder	9313074029
34	Inverter Case Assy	9315690029
35	Inverter Case Cover	9314507038
36	Terminal Bracket	9317691017
37	Terminal	9703874055
38	Bracket Conduit	9313938017
39	Terminal Cover Assy	9317898010
--	Discharge Thermistor	9900038045
--	Heat Exchanger Thermistor	9900403010
--	Outdoor Thermistor	9900210038

ACCESSORIES

Name and Shape	Part number
Wall hook bracket 	9315023018
Remote control 	9315027160
Remote control holder 	9305642045
Battery (penlight) 	0600185541
Cloth tape 	9310519004
Tapping screw (big) 	0700076046
Tapping screw (small) 	0700019036

