



F R I E D R I C H

SPLIT TYPE
ROOM AIR CONDITIONER
WALL MOUNTED TYPE

SERVICE MANUAL

Indoor unit	Outdoor unit
MW18Y3H	MR18Y3H
MW24Y3H	MR24Y3H



CONTENTS

SPECIFICATIONS	1
DIMENSIONS	2
REFRIGERANT SYSTEM DIAGRAM	4
CIRCUIT DIAGRAM	5
INDOOR PCB CIRCUIT DIAGRAM	7
OUTDOOR PCB CIRCUIT DIAGRAM	10
ERROR DERECTION	16
PARTS (INDOOR UNIT)	18
PARTS (OUTDOOR UNIT)	22
ACCESSORIES	26

SPECIFICATIONS

ELECTRICAL DATA

TYPE		Cool & heat inverter	
INDOOR UNIT		MW18Y3H	MW24Y3H
OUTDOOR UNIT		MR18Y3H	MR24Y3H
COOLING CAPACITY		18,000 BTU/h 5.28 kW	22,000 BTU/h 6.50 kW
HEATING CAPACITY		21,600 BTU/h 6.30 kW	27,600 BTU/h 8.10 kW
POWER SOURCE		208 V / 230 V	208 V / 230 V
FREQUENCY		60 Hz	60 Hz
RUNNING CURRENT	Cooling	6.3 A	7.9 A
	Heating	8.0 A	10.5 A
INPUT WATTS	Cooling	1.38 kW	1.76 kW
	Heating	1.80 kW	2.38 kW
E.E.R.	Cooling	13.0 BTU/kW 3.83 kW/kW	12.5 BTU/kW 3.69 kW/kW
COP	Heating	12.0 BTU/kW 3.50 kW/kW	11.6 BTU/kW 3.40 kW/kW
MOISTURE REMOVAL		5.9 Pt/h 2.8 L/hr	6.3 Pt/h 3.0 L/hr
AIR CIRCULATION HIGH		541 cfm 920 m ³ /hr	659 cfm 1,120 m ³ /hr
MAXIMUM CURRENT		14.5 A	15.5 A

FAN MOTOR

POWER SOURCE		230 V	230 V
INDOOR UNIT	High speed	1,260 r.p.m.	1,480 r.p.m.
	Middle speed	1,020 r.p.m.	1,220 r.p.m.
	Low speed	900 r.p.m.	1,020 r.p.m.
	Quiet	770 r.p.m.	900 r.p.m.
OUTDOOR UNIT	Cool	620 r.p.m.	800 r.p.m.
	Heat	620 r.p.m.	850 r.p.m.

NOISE LEVEL

INDOOR UNIT	Cool 43 dB / Heat 44 dB	Cool 49 dB / Heat 49 dB
OUTDOOR UNIT	Cool 47 dB / Heat 50 dB	Cool 54 dB / Heat 55 dB

COMPRESSOR AND REFRIGERANT

TYPE		Hermetic type, 6 pole, DC inverter motor, Rotary	
DISCRIMINATION		N-TF30ND1A	
WEIGHT WITH OIL		34.2 lb	15.5 kg
PRECHARGED REFRIGERANT		4 lb 10 oz	2,100 g
REFRIGERANT TYPE		R410A	
FULL CHARGE	Pipe length 66 ft 20 m	4 lb 10 oz	2,100 g
	164 ft 50 m	7 lb 4 oz	3,300 g
ADDITIONAL CHARGE		0.43 oz/ft	40 g/m

DIMENSIONS

INDOOR UNIT	H x W x D	12-5/8 x 39-1/4 x 9 inch	320 x 998 x 228 mm
OUTDOOR UNIT	H x W x D	32-3/4 x 35-3/8 x 13 inch	830 x 900 x 330 mm

WEIGHT

INDOOR UNIT	Shipping / Net	40 lbs / 31 lbs	18 kg / 14 kg
OUTDOOR UNIT	Shipping / Net	150 lbs / 135 lbs	68 kg / 61 kg

DIMENSIONS

INDOOR UNIT

Unit : inch (mm)

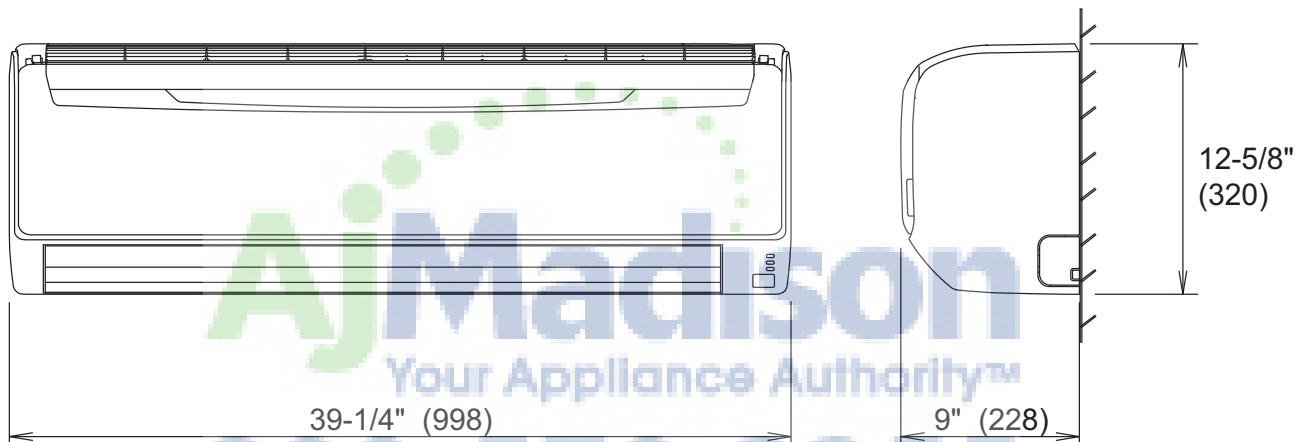

Drain pipe diameter
Inside : 5/8 inch (16 mm)
Outside : 1-3/32 inch (28 mm)

Liquid pipe diameter : 3/8 inch (9.52 mm)
Gas pipe diameter : 5/8 inch (15.88 mm)

OUTDOOR UNIT

Unit : inch (mm)

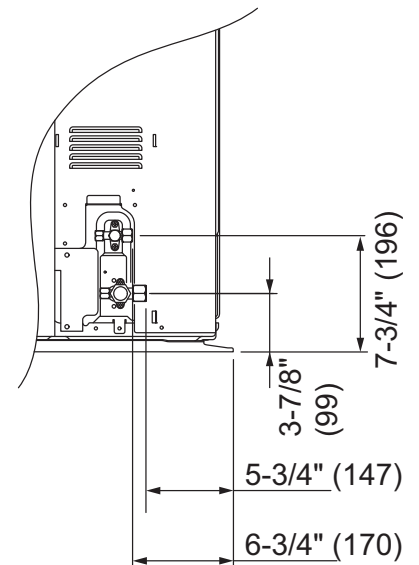
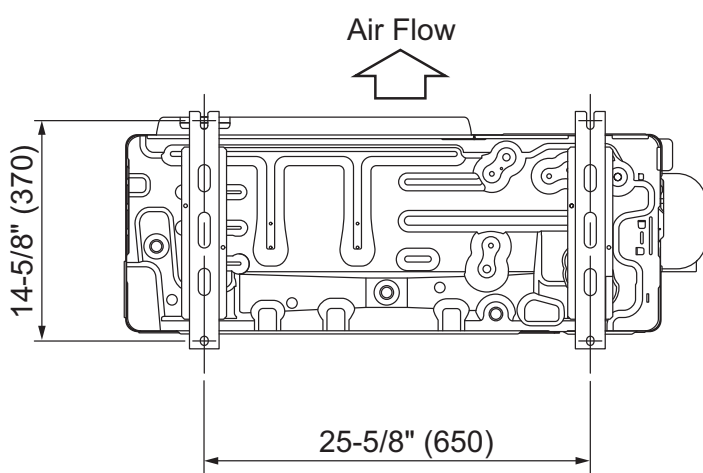
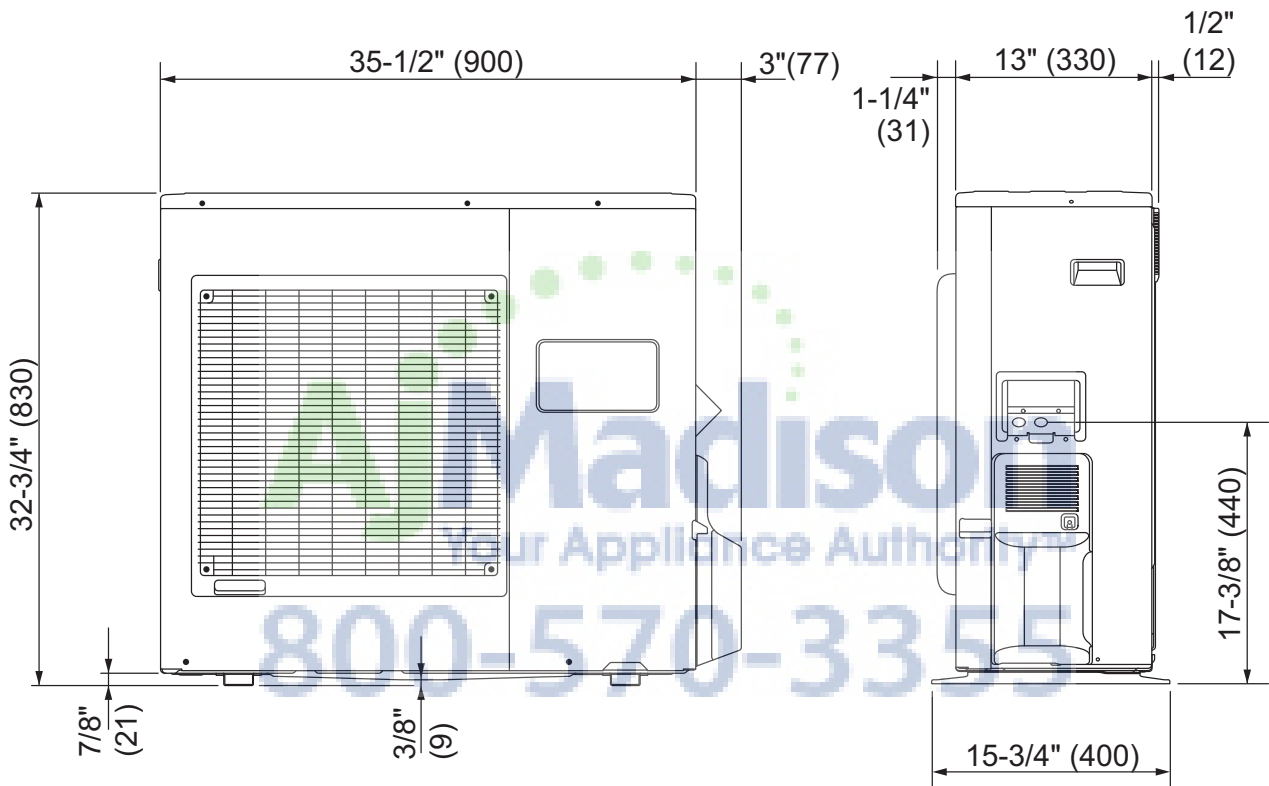
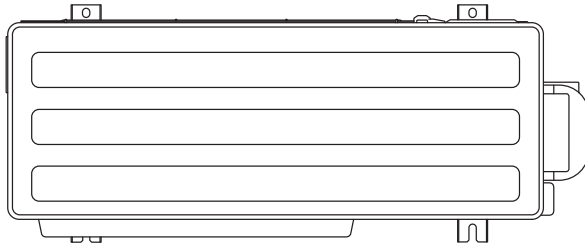

REFRIGERANT SYSTEM DIAGRAM

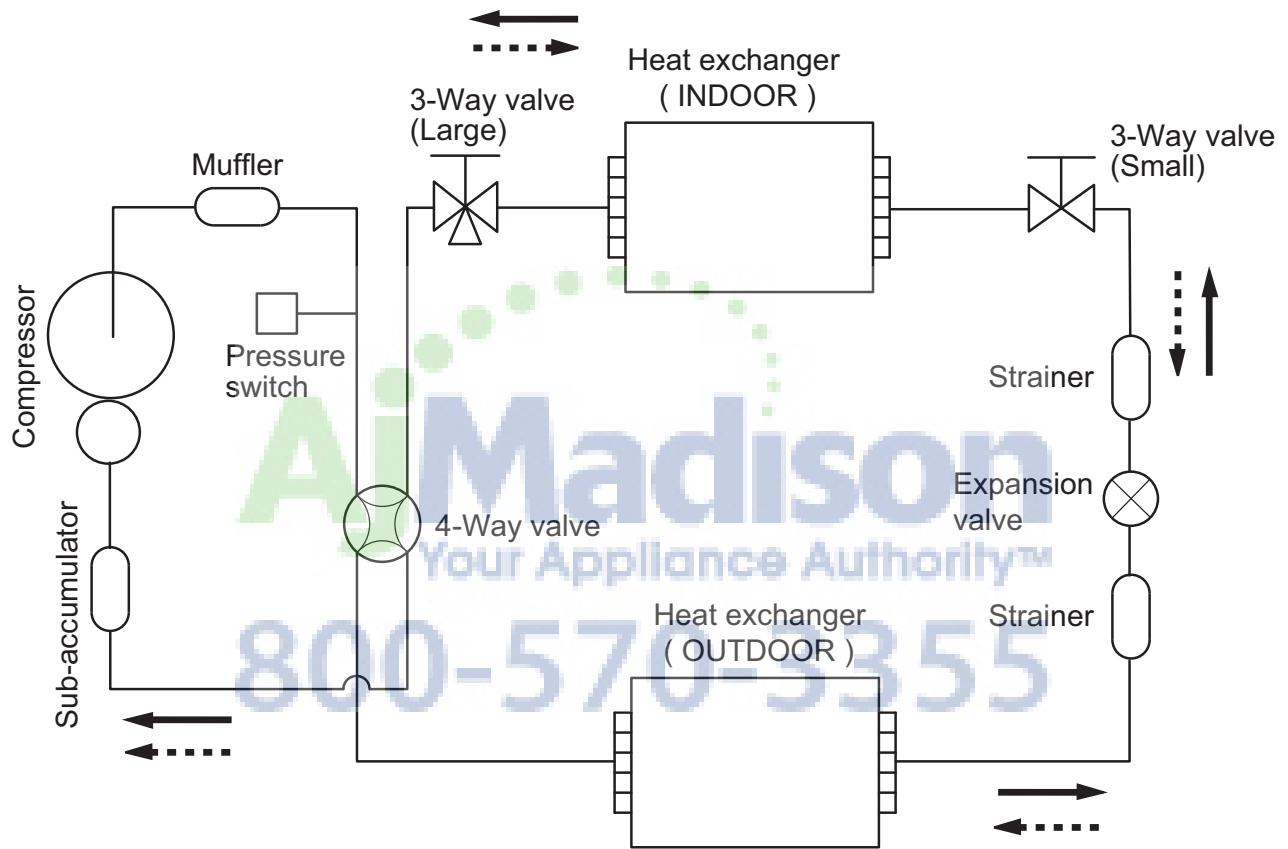

———→ Cooling flow
 - - - -> Heating flow

Refrigerant pipe diameter
 Liquid : 3/8" (9.52 mm)
 Gas : 5/8" (15.88 mm)

CIRCUIT DIAGRAM

MW18Y3H / MR18Y3H

INDOOR UNIT

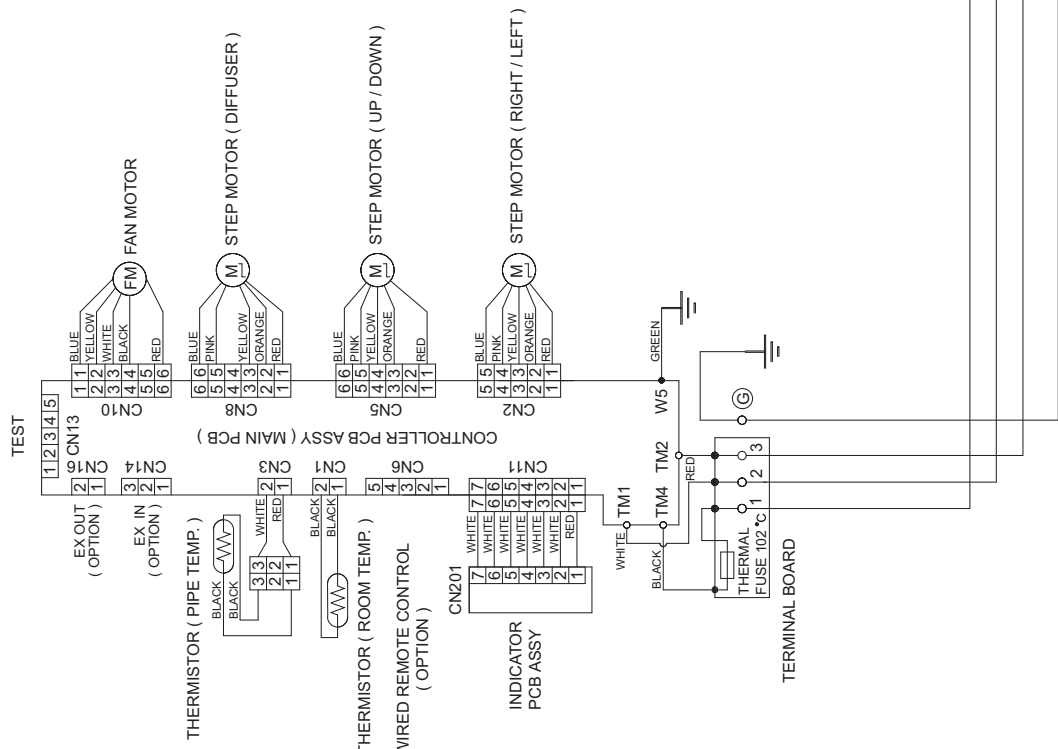

OUTDOOR UNIT

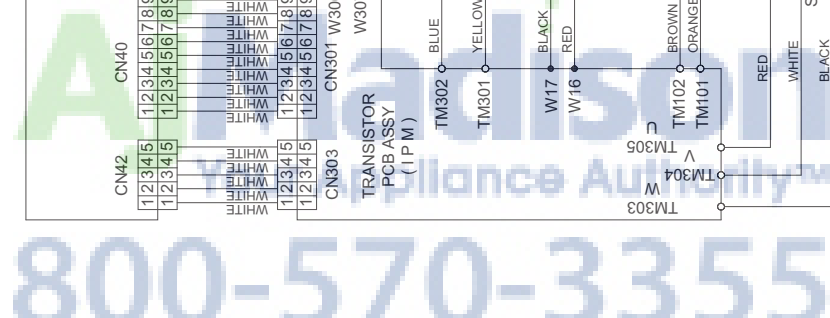
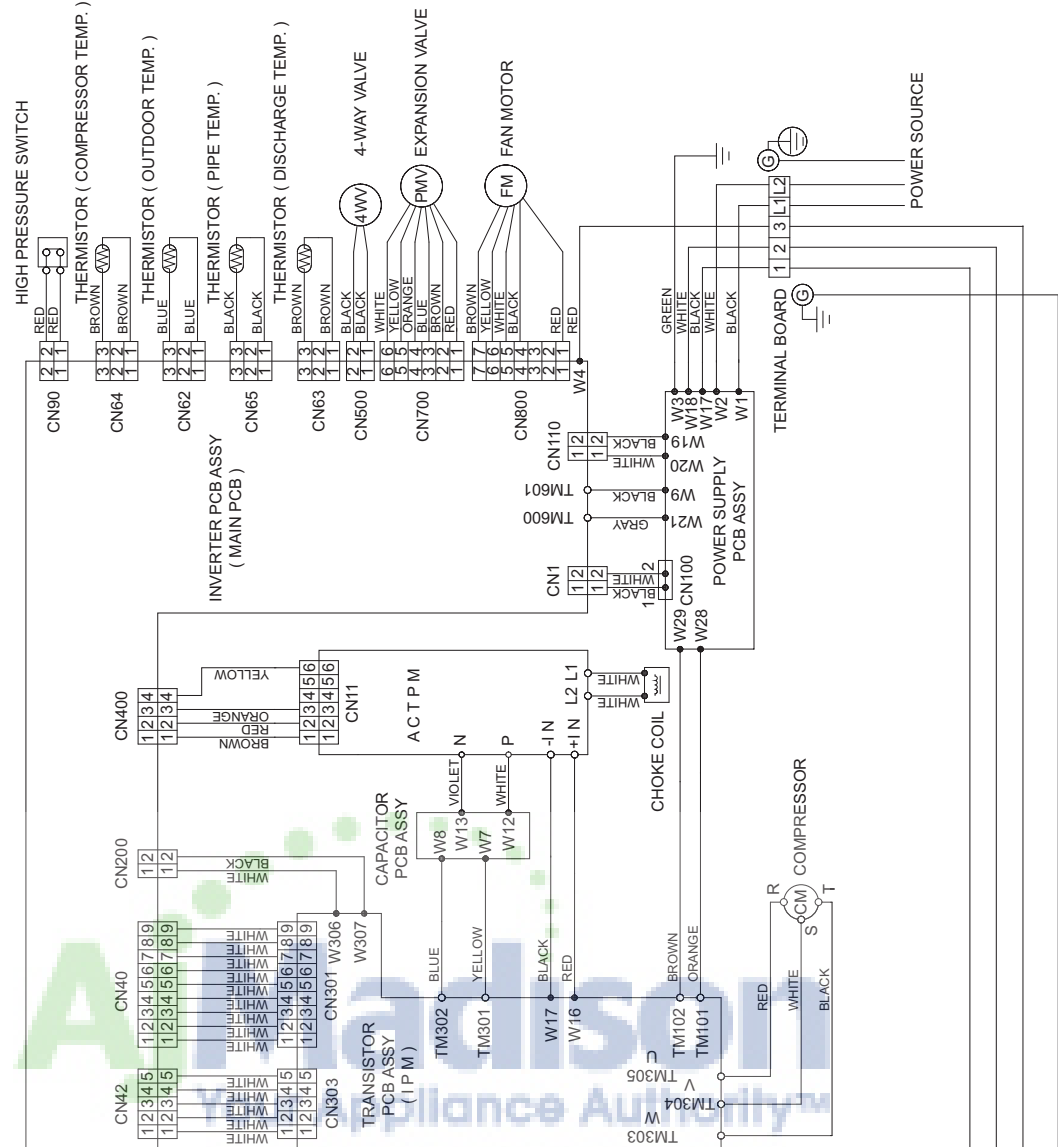

MW24Y3H / MR24Y3H

INDOOR UNIT

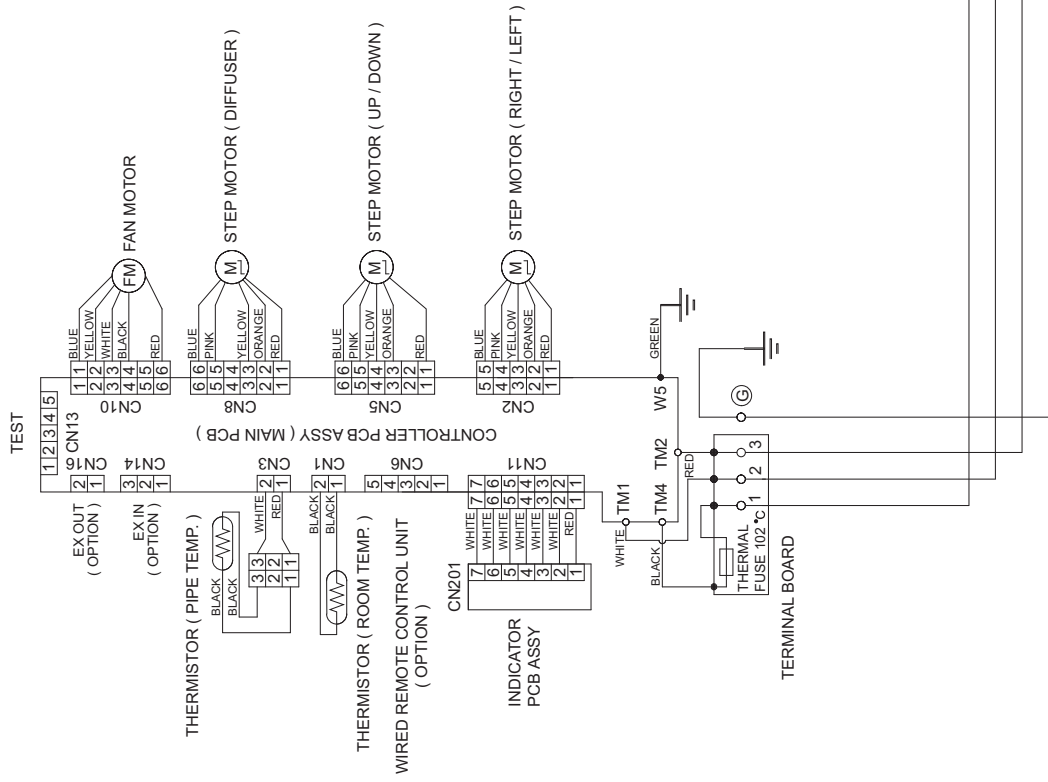

OUTDOOR UNIT

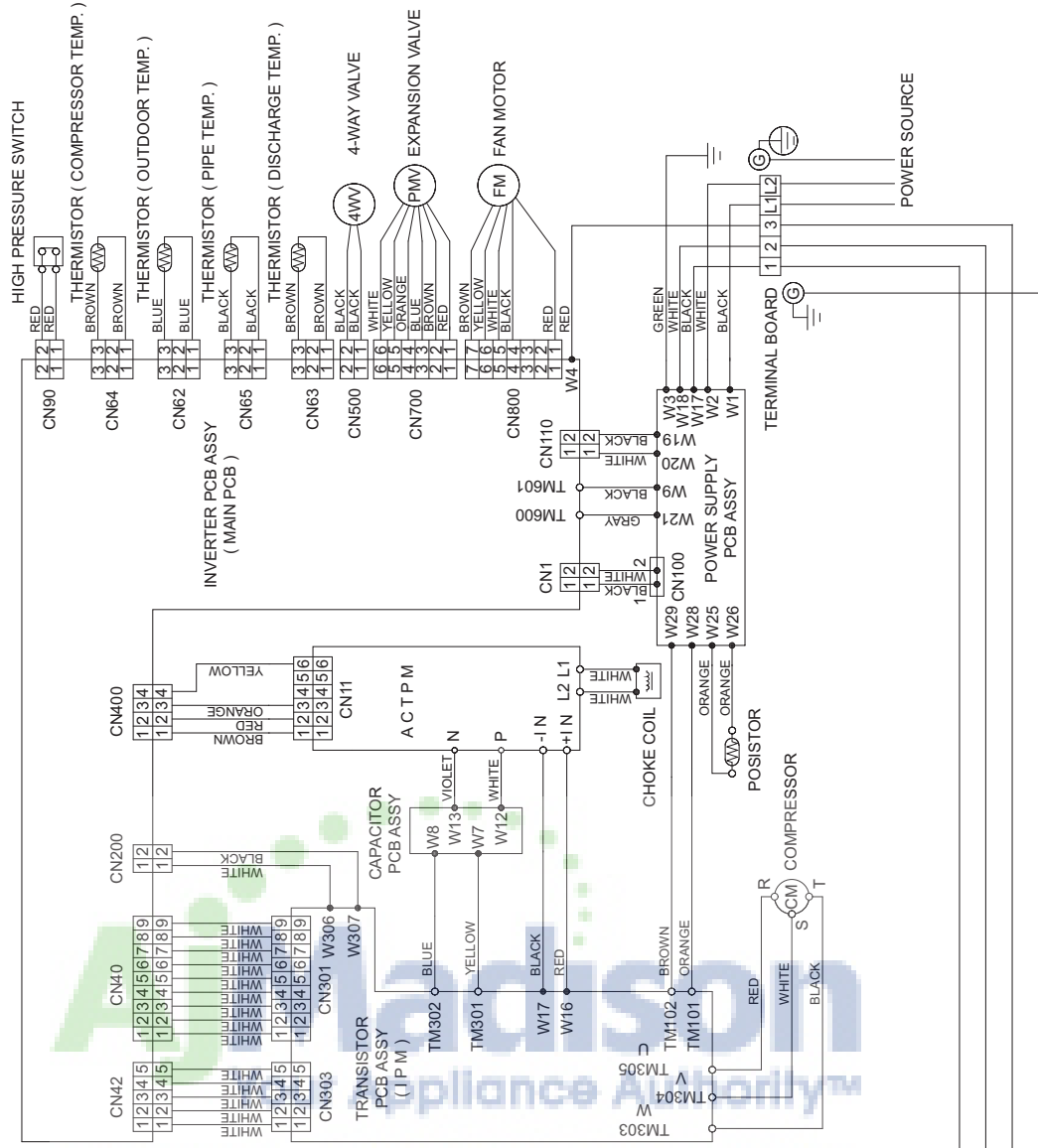

800-570-3355

INDOOR PCB CIRCUIT DIAGRAM

CONTROL UNIT

MW18Y3H : EZ-0090HHSE

MW24Y3H : EZ-0090KHSE

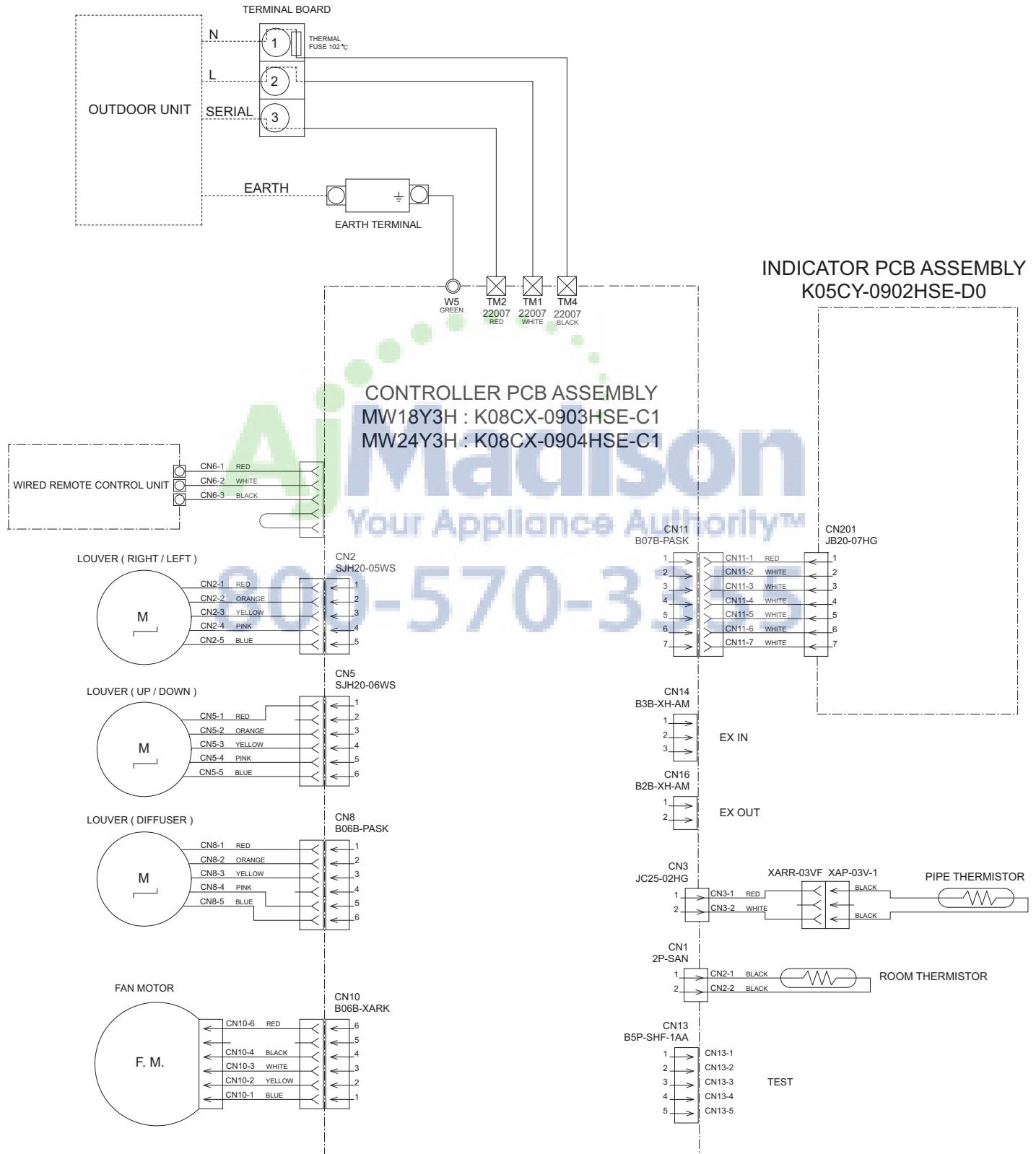

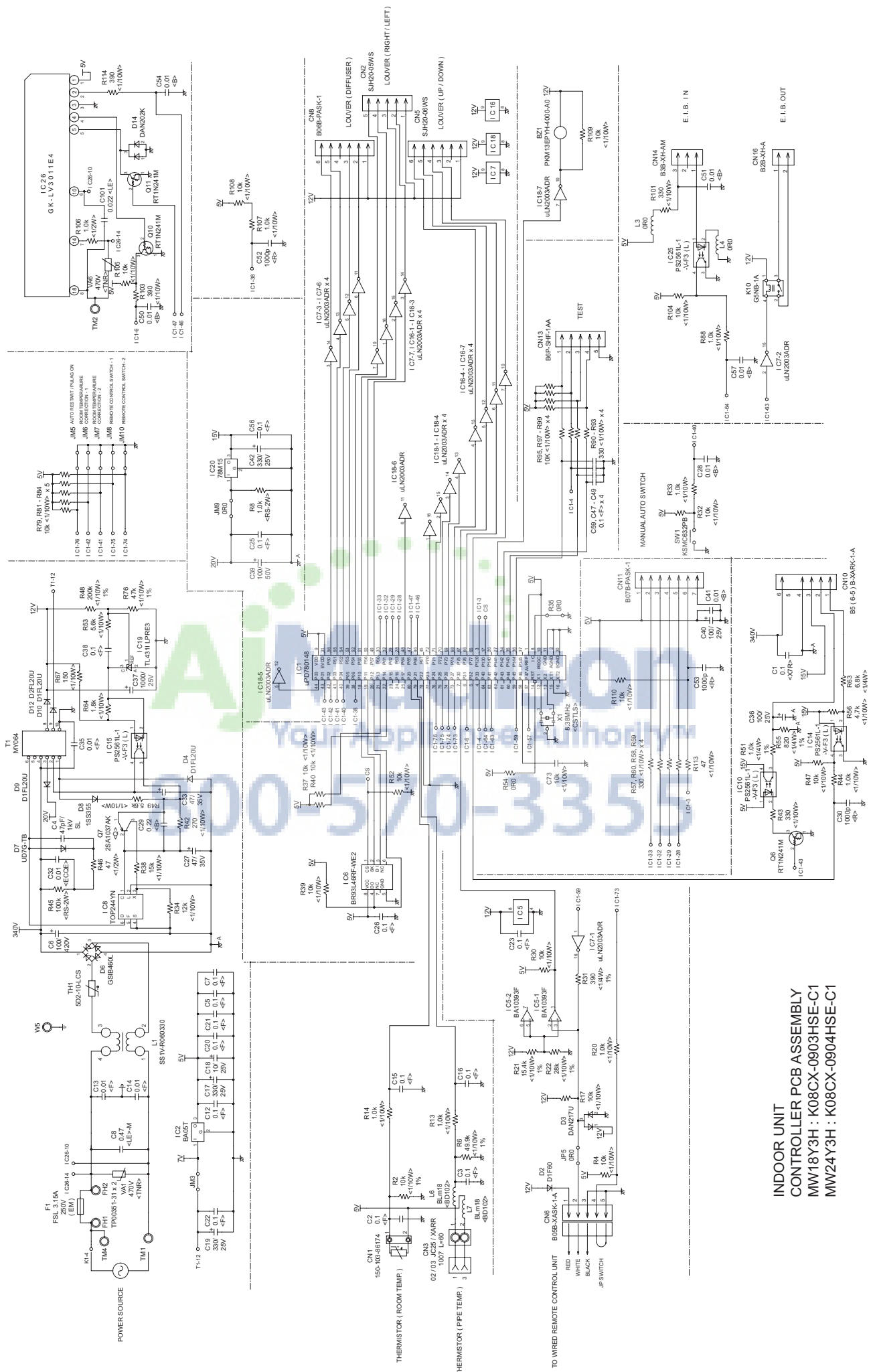

INDOOR UNIT
 CONTROLLER PCB ASSEMBLY
 MW18Y3H : K08CX-0903HSE-C1
 MW24Y3H : K08CX-0904HSE-C1

**OUTDOOR UNIT
MR18Y3H
POWER SUPPLY PCB ASSEMBLY
K09DH-0904HUE-FLO**

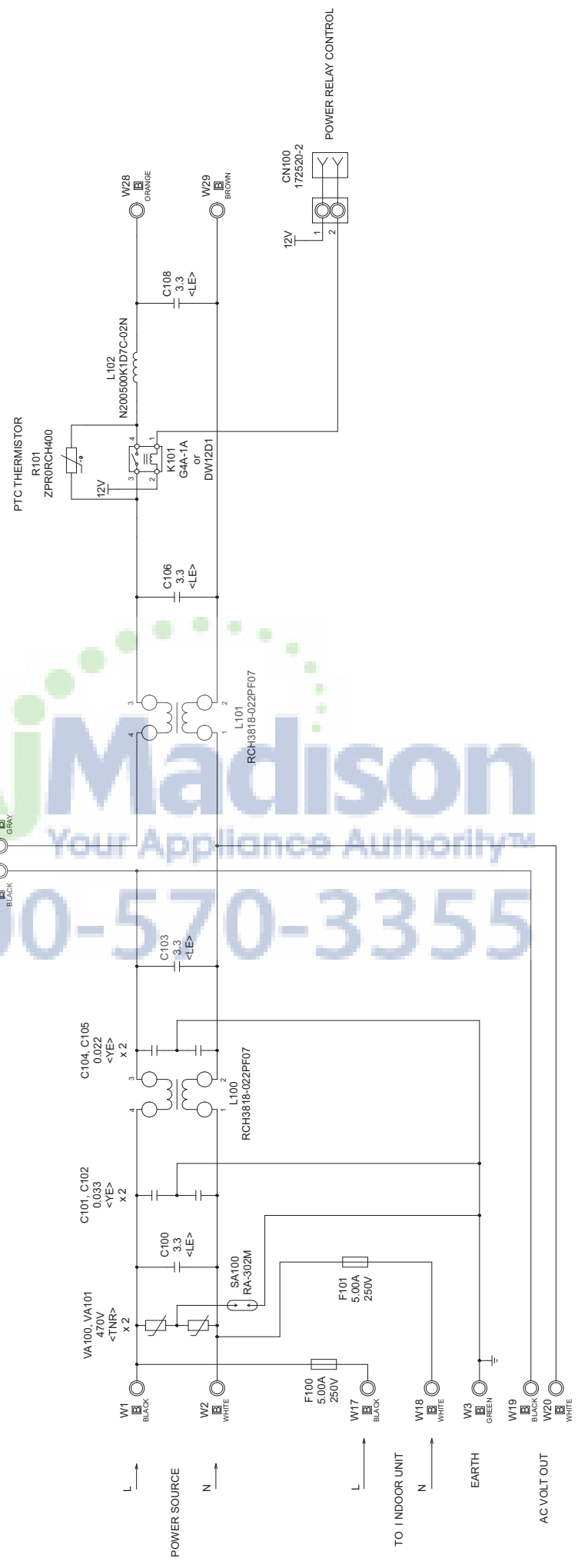
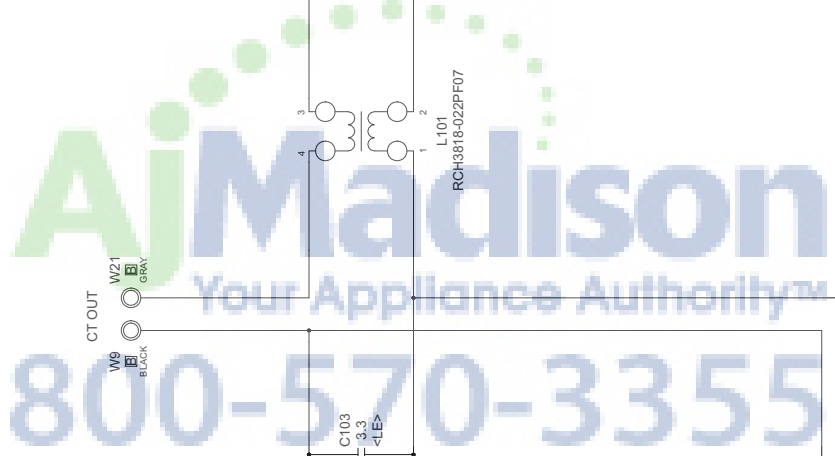

OUTDOOR UNIT
 MR24Y3H
 POWER SUPPLY PCB ASSEMBLY
 K09DH-0900HUE-FLO

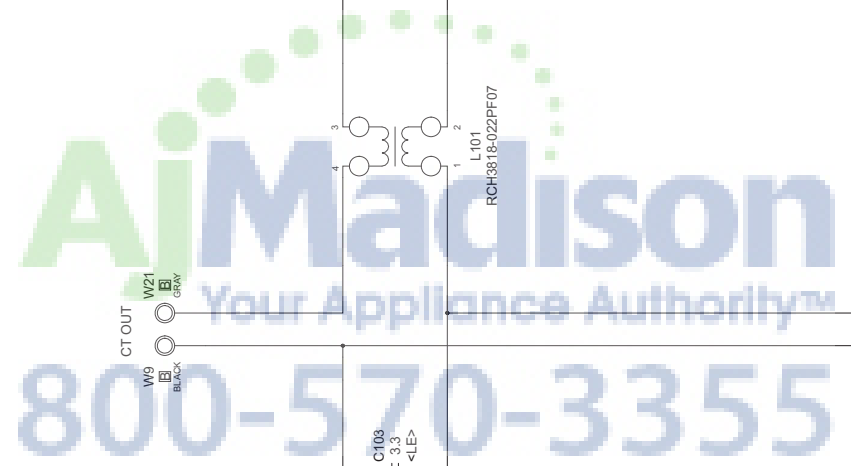
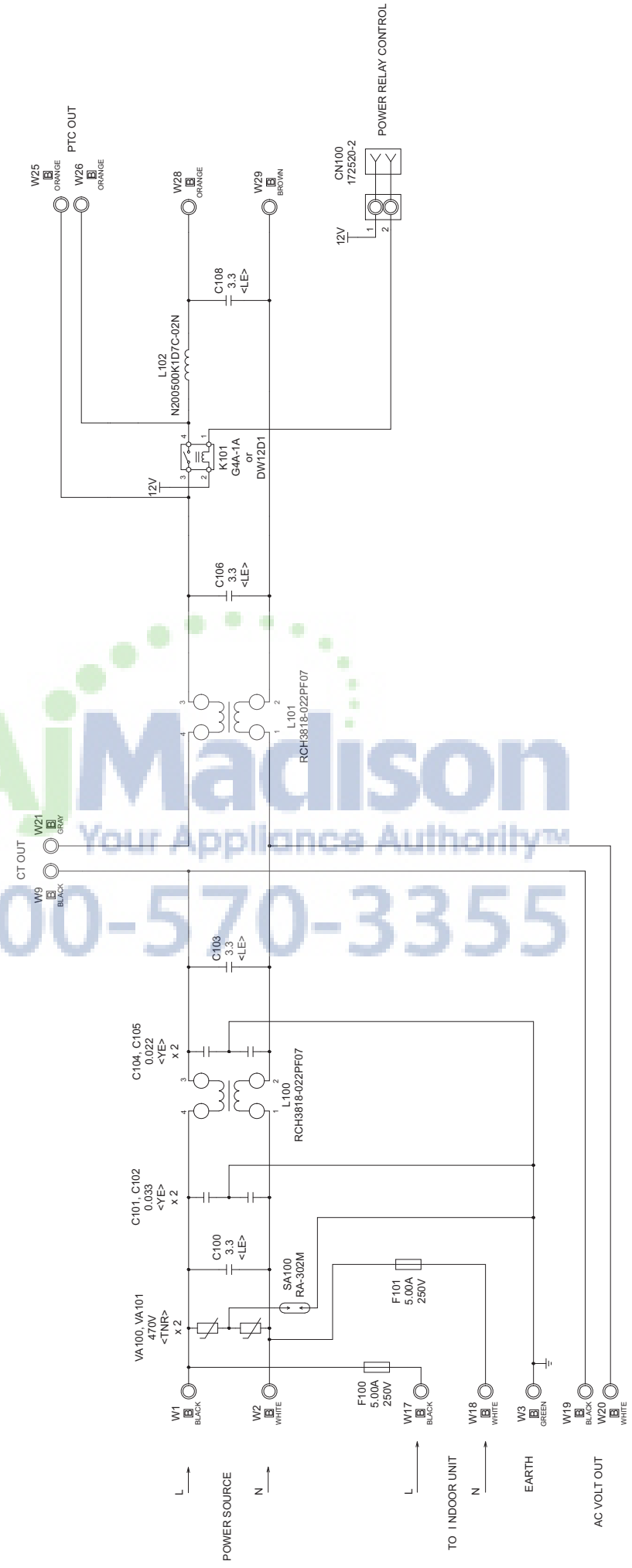

OUTDOOR UNIT
 MR18Y3H
 CAPACITOR PCB ASSEMBLY
 K05FB-0902HUE-P0

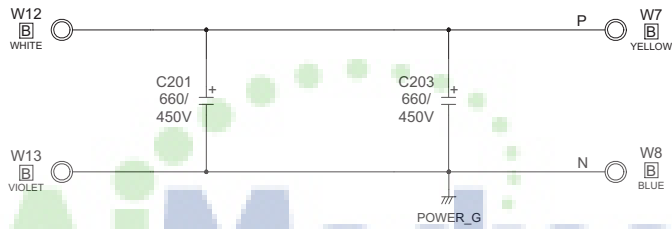

800-570-3355

MR24Y3H
 CAPACITOR PCB ASSEMBLY
 K05FB-0903HUE-P0

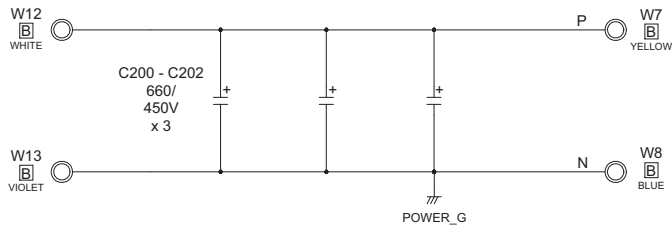

ERROR DETECTION

Error	Display		Error
	Operation LED	Timer LED	
Serial signal error	Normal	2 flash	Serial signal (reverse) error, at operation start up
		3 flash	Serial signal (reverse) error, during operation
		4 flash	Serial signal (forward) error, at operation start up
		5 flash	Serial signal (forward) error, during operation
		8 flash	Wired remote controller error
Indoor unit thermistor error	2 flash	2 flash	Indoor temperature thermistor open / short
		3 flash	Heat exchanger middle thermistor open / short
Outdoor unit thermistor error	3 flash	2 flash	Discharge thermistor open / short
		3 flash	Heat exchanger thermistor open
		4 flash	Outdoor temperature thermistor open / short
		8 flash	Compressor temperature thermistor open / short
Indoor unit control error	4 flash	2 flash	Forced automatic SW welded
		3 flash	Main relay welded
		4 flash	Power interruption error
		7 flash	VDD permanent stop protection
		8 flash	reverse VDD permanent stop protection
Outdoor unit control error	5 flash	2 flash	Current trip error
		3 flash	CT abnormal
		5 flash	Compressor location detection error
		6 flash	Outdoor unit fan drive system abnormal
Indoor fan motor error	6 flash	2 flash	Abnormal lock
		3 flash	Abnormal rotation
Refrigerant cycle error	7 flash	2 flash	Discharge Temperature abnormal
		3 flash	Cooling high pressure abnormal rise
		5 flash	Pressure switch trouble
Optional function error	8 flash	2 flash	Active filter voltage trouble (second time)
		3 flash	Active filter voltage trouble (first time)
		4 flash	PFC circuit error
Model information error	0.1 sec on/off	0.1 sec on/off	Model information error

OUTDOOR UNIT

LED	ERROR
on	Discharge temperature abnormal
0.5 second on / 0.5 second off	IPM overcurrent protection
0.1 second on / 0.1 second off	Thermistor abnormal
2.0 second on / 2.0 second off	CT abnormal
0.1 second on / 2.0 second off	Compressor location abnormal
5.0 second on / 5.0 second off	Fan abnormal

PARTS

INDOOR UNIT

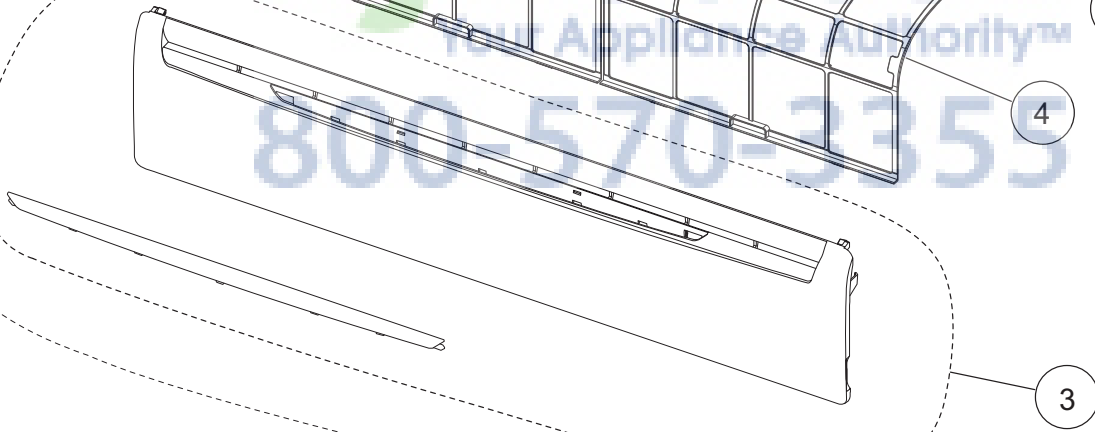
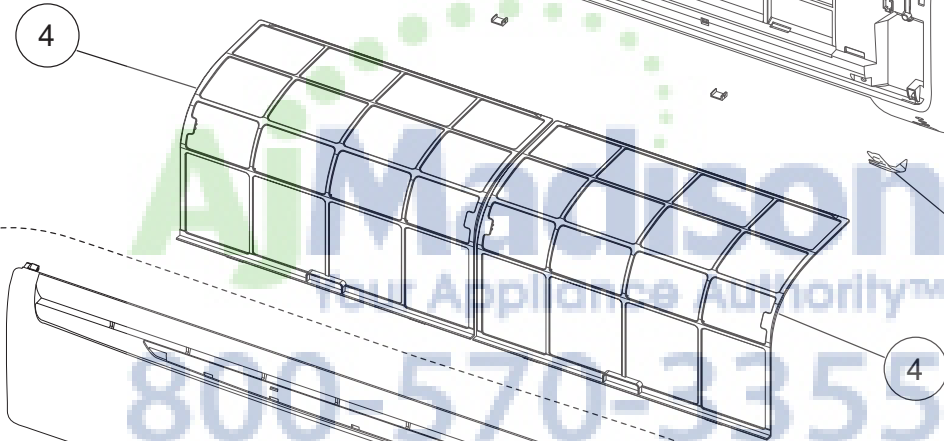
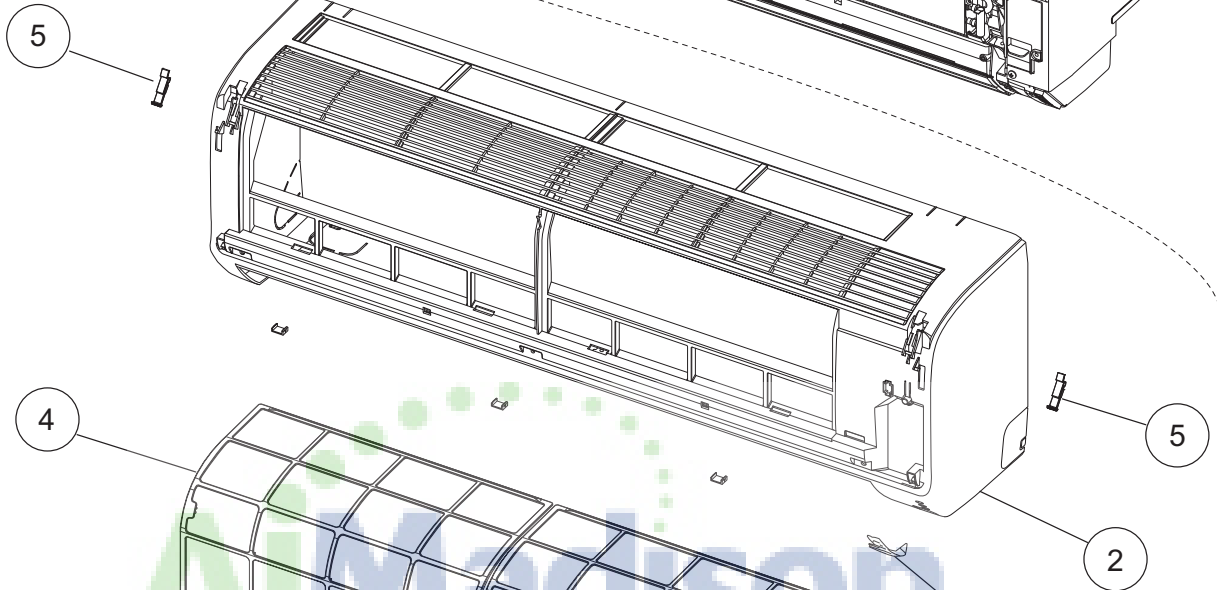
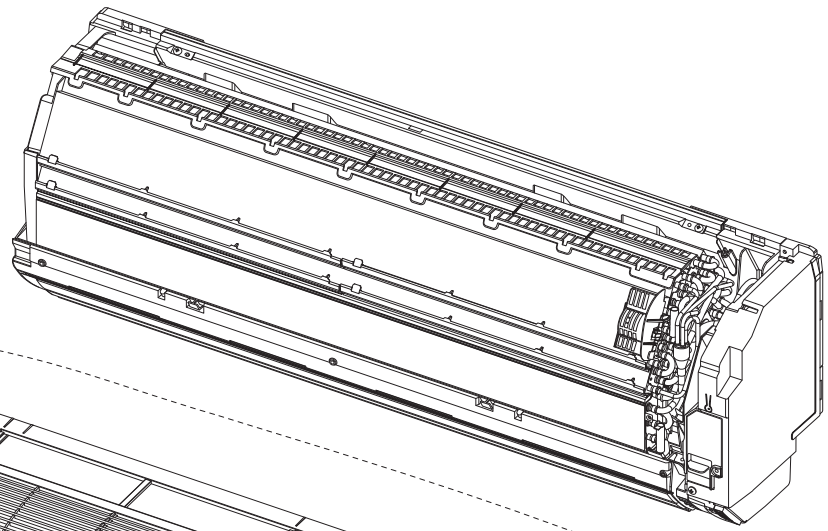

Ref	Description	Part number
1	Front Panel Total Assy	9315335258
2	Front Panel	9314991080
3	Intake Grille Assy	9315336064
4	Air Filter	9315014016
5	Clamper Grille	9306755010
6	Receiver Window	9315010018
--	Remote	9379219013
--	Remote Holder	9305642045

INDOOR UNIT

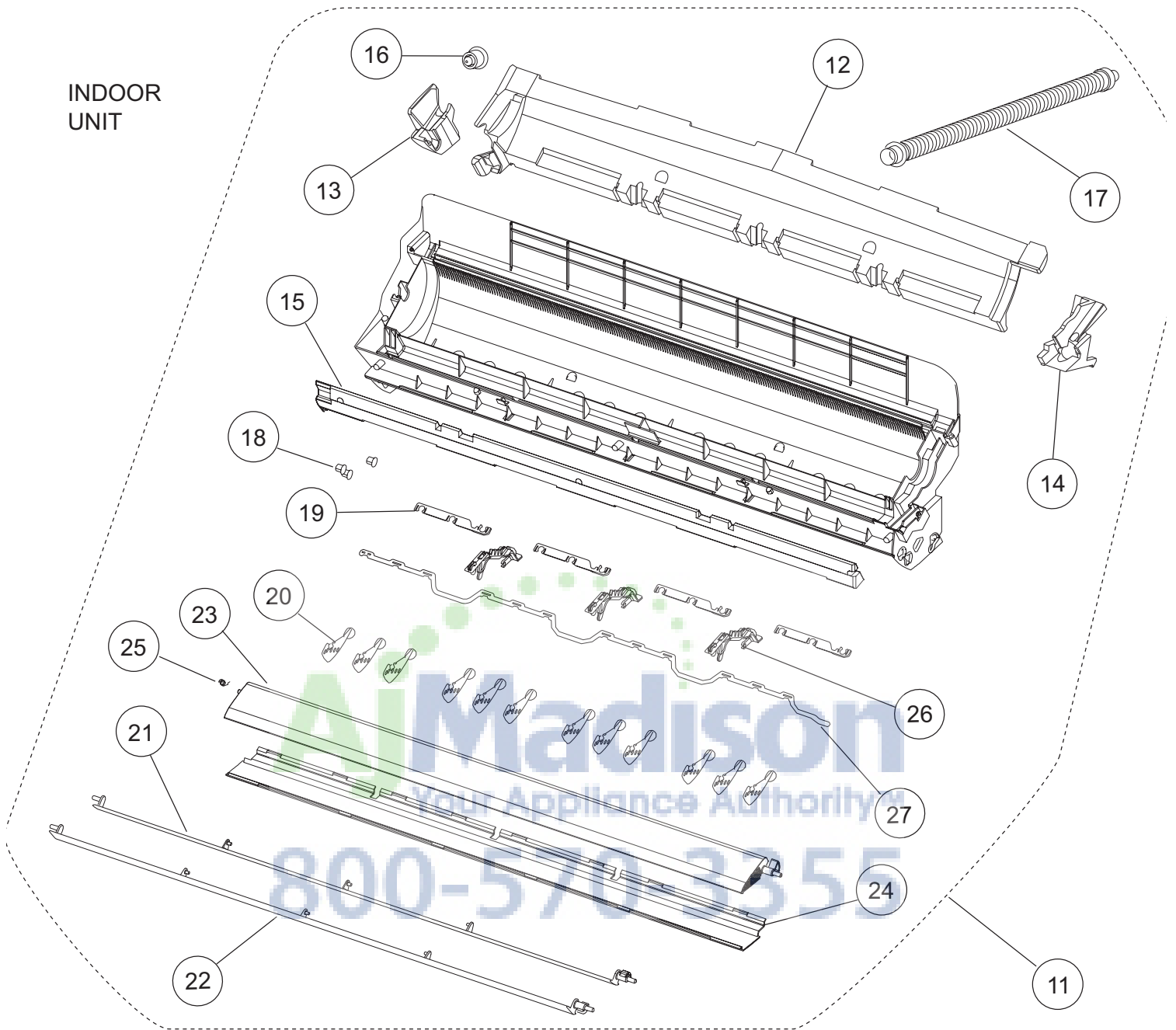

Ref	Description	Part number	Ref	Description	Part number
11	Casing Assy	9315331045	21	Louver U	9315000019
12	Casing Cover B	9315016010	22	Louver Z	9315001016
13	Casing Cover L	9315017017	23	Diffuser U	9315002013
14	Casing Cover R	9315018014	24	Diffuser Z	9315003010
15	Casing Cover F	9315019011	25	Spring C	9314142017
16	Drain Cap	9367677009	26	Pillar A	9315009012
17	Drain Hose Assy	9315769015	27	Joint B	9315006011
18	Bush B	9312156016	--	Fan Guard	9305751051
19	Spacer B	9312441013	--	Fan Guard Holder Right	9315814012
20	R and L Louver	9311997016	--	Fan Guard Holder Left	9315815019

INDOOR UNIT

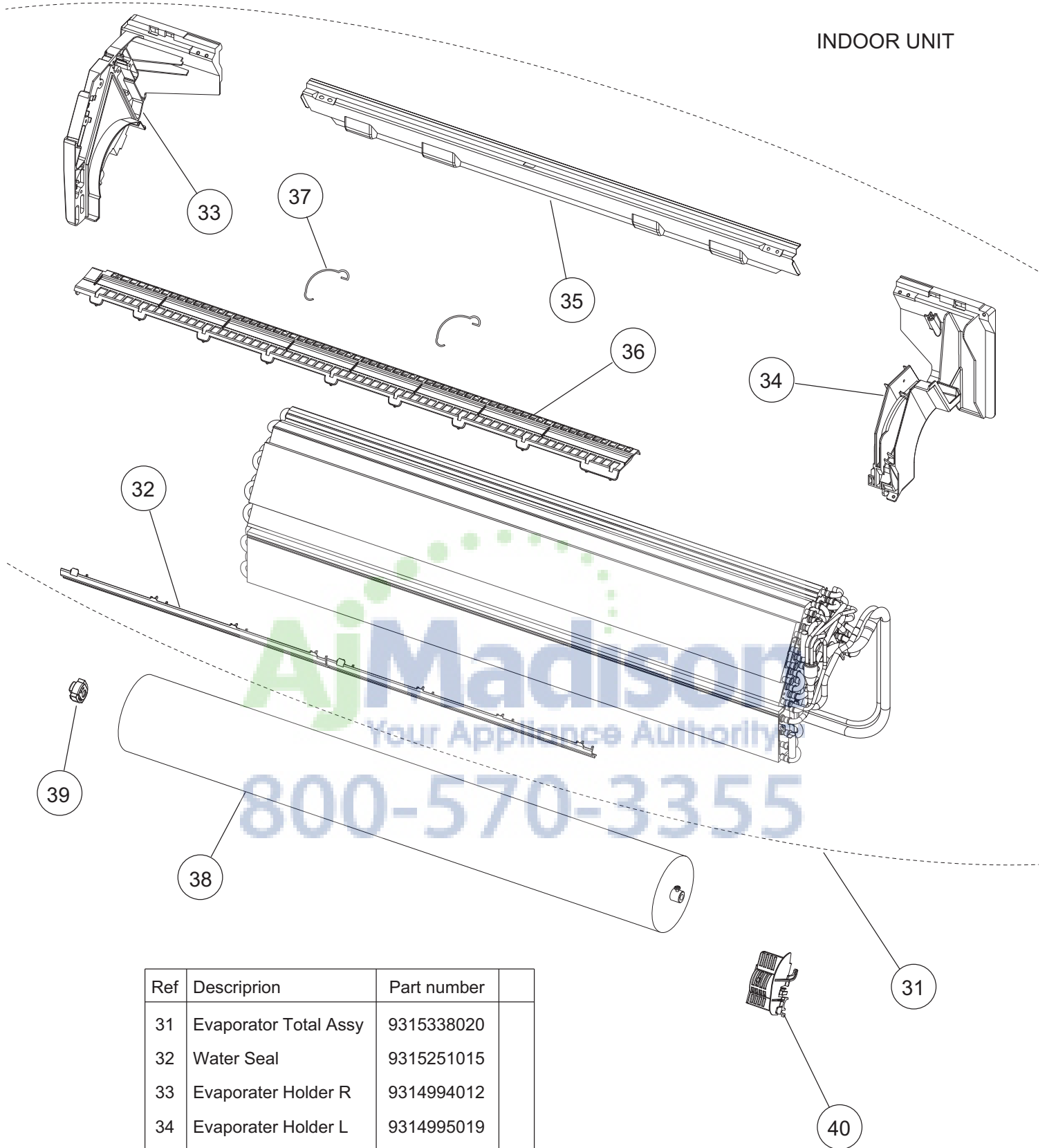

Ref	Description	Part number
31	Evaporator Total Assy	9315338020
32	Water Seal	9315251015
33	Evaporater Holder R	9314994012
34	Evaporater Holder L	9314995019
35	Rear Bracket	9315022011
36	Filter Guide	9315013019
37	Filter Guard	9315411013
38	Crossflow Fan Assy	9315024015
39	Bearing C Assy	9306628017
40	Room Therimistor Holder	9315252012

INDOOR UNIT

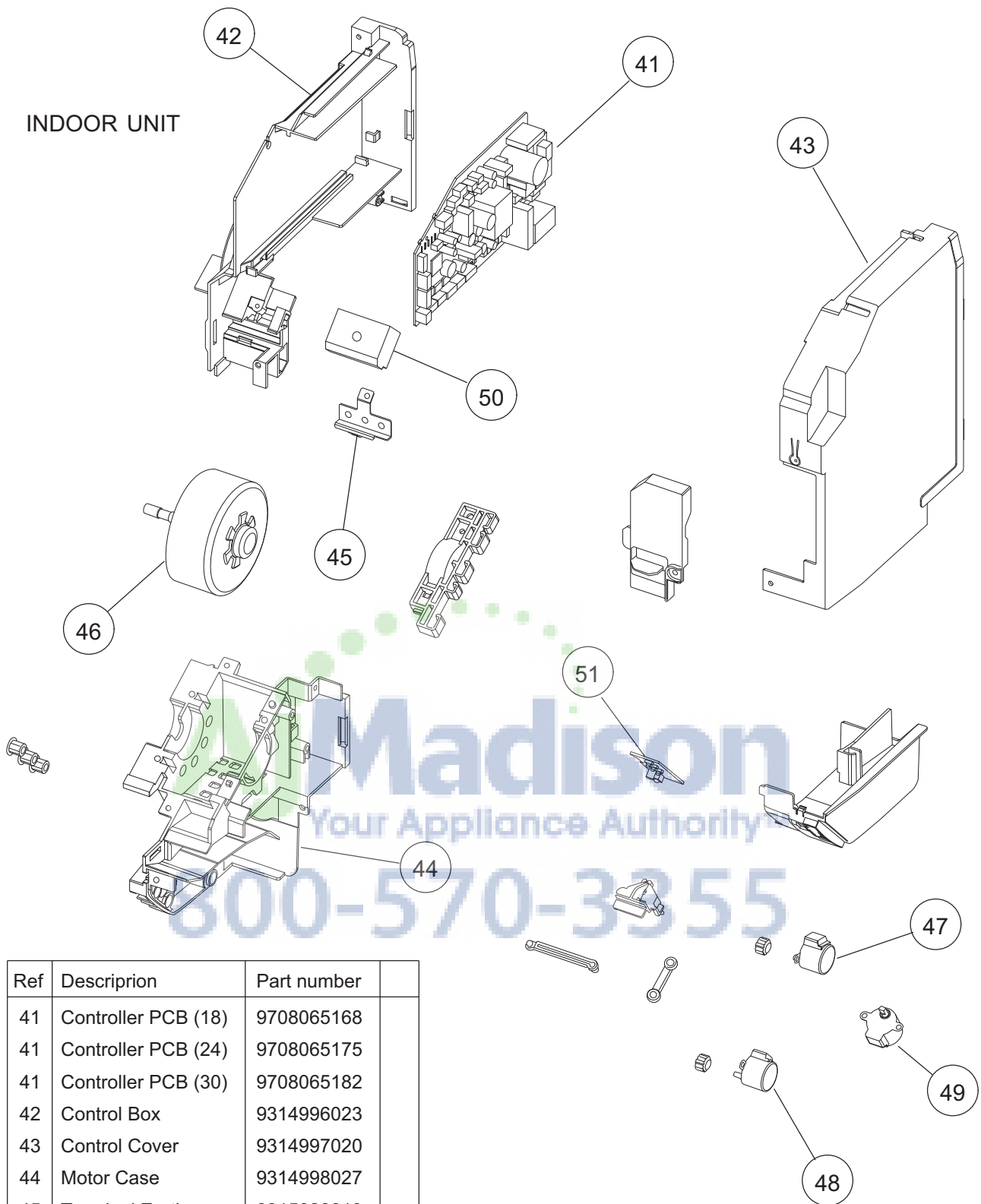

Ref	Description	Part number
41	Controller PCB (18)	9708065168
41	Controller PCB (24)	9708065175
41	Controller PCB (30)	9708065182
42	Control Box	9314996023
43	Control Cover	9314997020
44	Motor Case	9314998027
45	Terminal Earth	9315028013
46	DC Brushless Motor	9602784004
47	Motor, Step	9900384029
48	Motor, Step	9900384036
49	Motor, Step	9900139063
50	Terminal	9900447014
51	Indicator PCB Assy	9707210057
--	Pipe Thermistor	9900551018

Controller PCB includes a room thermistor.

PARTS

OUTDOOR UNIT

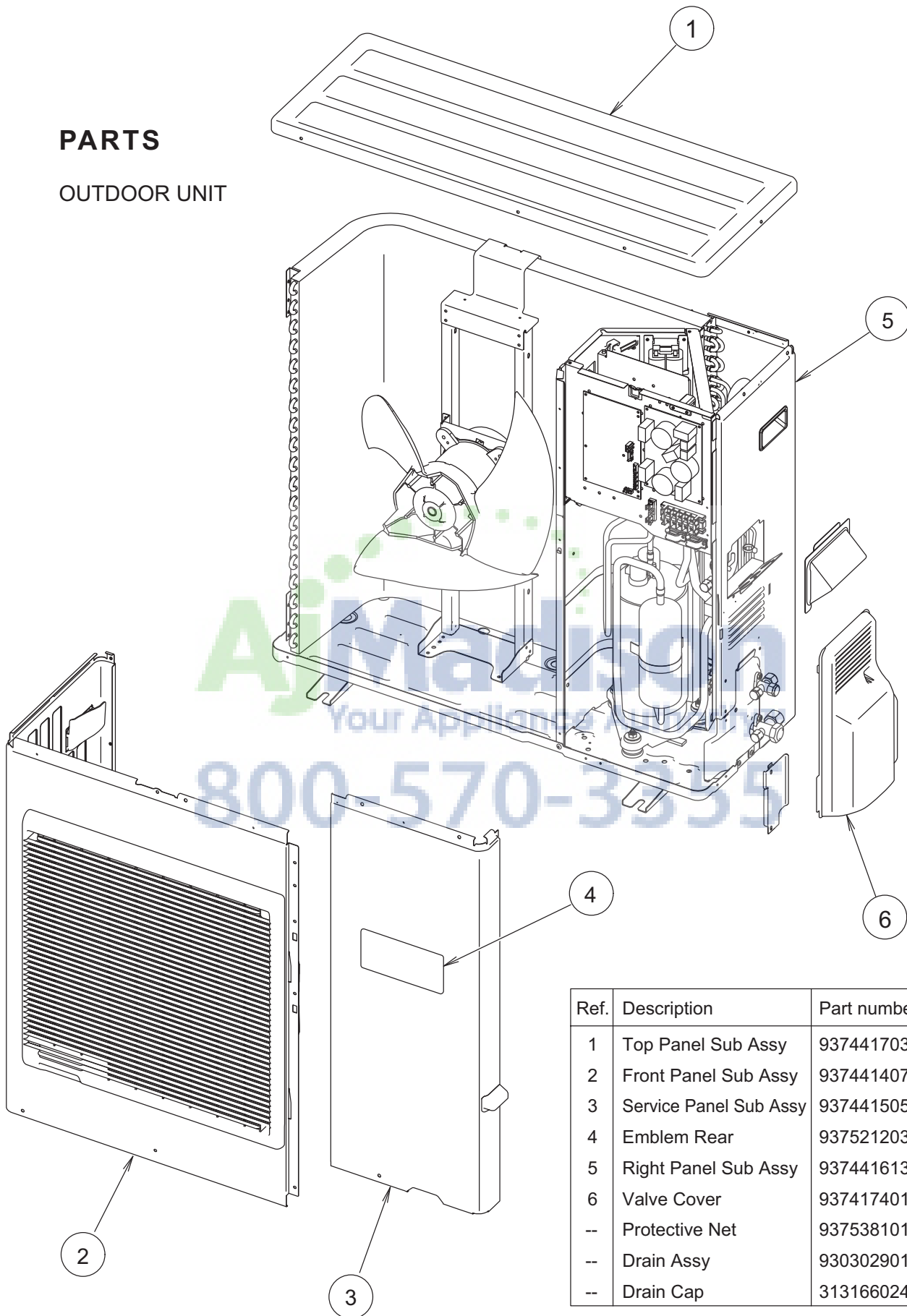

Ref.	Description	Part number
1	Top Panel Sub Assy	9374417032
2	Front Panel Sub Assy	9374414079
3	Service Panel Sub Assy	9374415052
4	Emblem Rear	9375212032
5	Right Panel Sub Assy	9374416134
6	Valve Cover	9374174010
--	Protective Net	9375381011
--	Drain Assy	9303029015
--	Drain Cap	313166024302

OUTDOOR UNIT

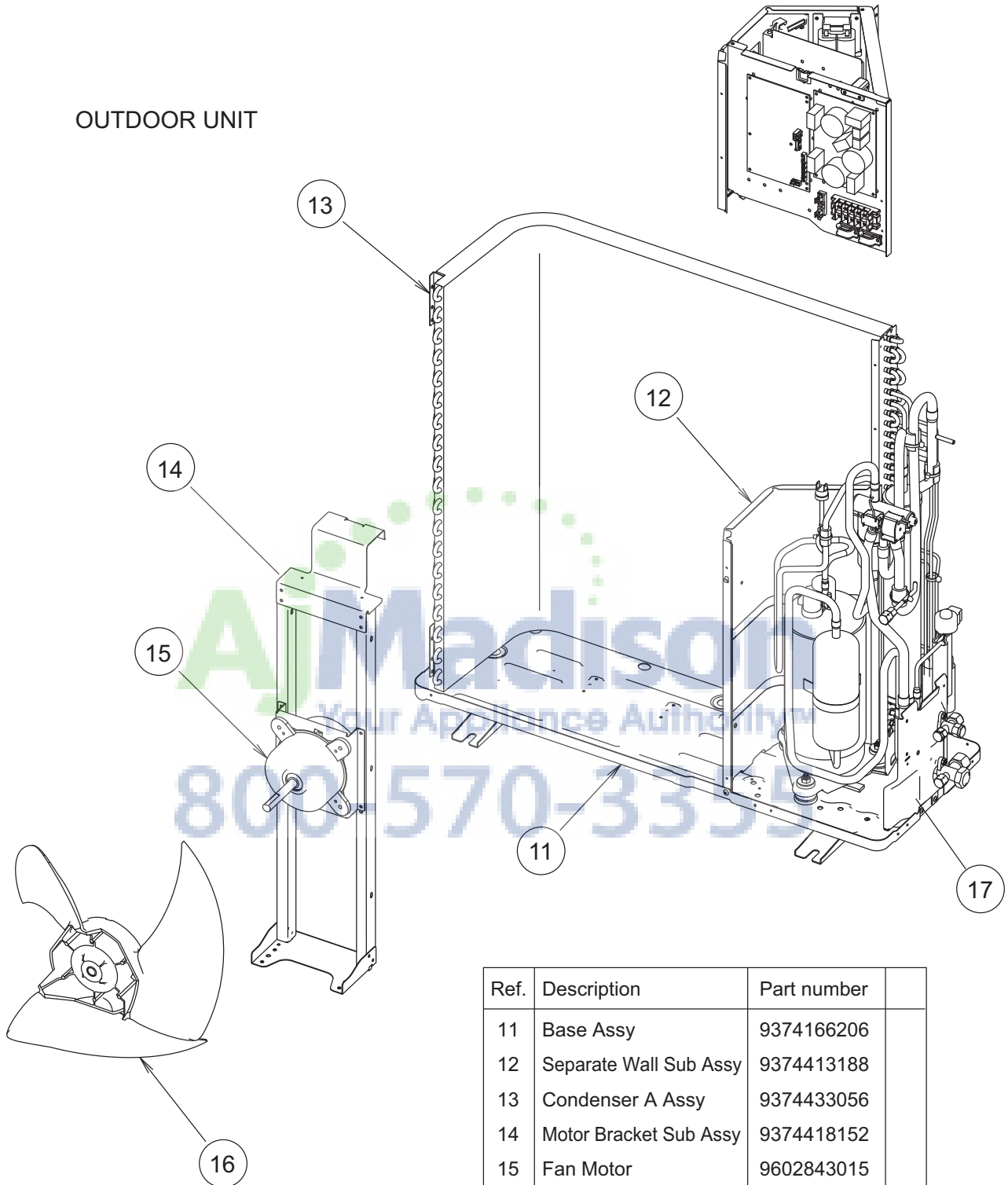

Ref.	Description	Part number
11	Base Assy	9374166206
12	Separate Wall Sub Assy	9374413188
13	Condenser A Assy	9374433056
14	Motor Bracket Sub Assy	9374418152
15	Fan Motor	9602843015
16	Propeller Fan Assy	9366378020
17	Valve Plate	9374099030

OUTDOOR UNIT

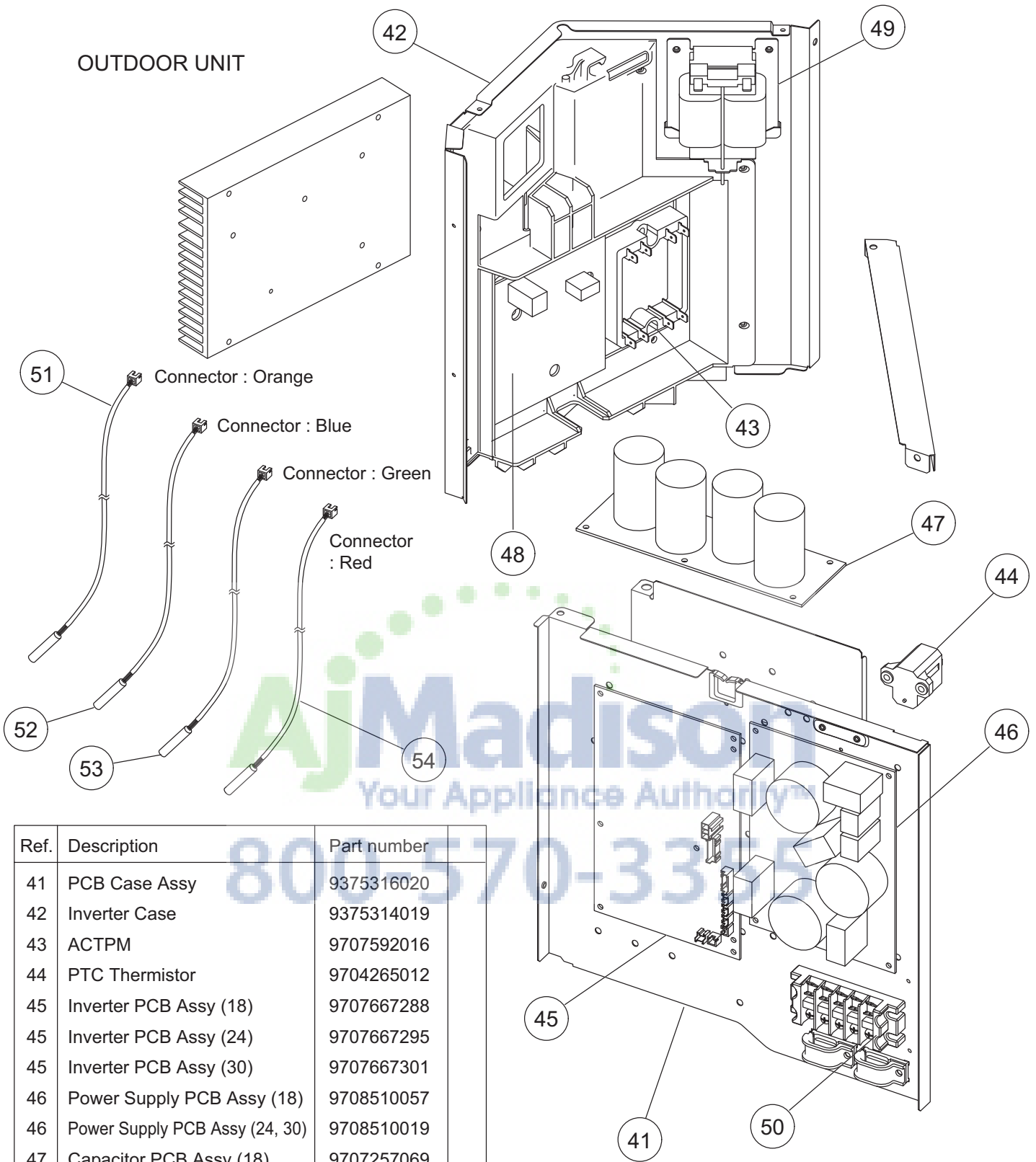

Ref.	Description	Part number
41	PCB Case Assy	9375316020
42	Inverter Case	9375314019
43	ACTPM	9707592016
44	PTC Thermistor	9704265012
45	Inverter PCB Assy (18)	9707667288
45	Inverter PCB Assy (24)	9707667295
45	Inverter PCB Assy (30)	9707667301
46	Power Supply PCB Assy (18)	9708510057
46	Power Supply PCB Assy (24, 30)	9708510019
47	Capacitor PCB Assy (18)	9707257069
47	Capacitor PCB Assy (24, 30)	9707257076
48	Transistor PCB Assy (18)	9707669114
48	Transistor PCB Assy (24, 30)	9707669121
49	Choke Coil	9900223014
50	Terminal	9900203023
51	Discharge Thermistor	9900461003
52	Outdoor Thermistor	9900463007
53	Compressor Thermistor	9900466015
54	Heat Exchanger Thermistor	9900514013

ACCESSORIES

Name and Shape	Part number
Wall hook bracket 	9315023018
Remote control 	9379219013
Remote control holder 	9305642045
Battery (penlight) 	0600185534
Cloth tape 	9310519004
Tapping screw (big) 	0700076046
Tapping screw (small) 	0700019036
Air cleaning filter 	9312153060 9311925071
Air cleaning filter frame 	9368568009
Drain pipe (Outdoor unit) 	9301102000
Drain cap (Outdoor unit) 	313166024302

