

SINCCOM1

3.88" x 12.88" x 16.75" (H x W x D)

110V induction cooktop for portable commercial use

Highlights:

Commercially listed to NSF standards

Instantly heats to cook in half the time of standard gas and electric ranges

Portable design for versatile use and easy storage

Genuine Ceran surface made of durable, low maintenance black glass



Commercially approved	ETL-S listed to NSF standards for commercial use
Ceran™ surface	Smooth surface made of durable and elegant black glass
Portable design	Freestanding unit can be used wherever extra cooking power is needed
Multiple power levels	Get precise and instant control of heating temperature with adjustable touch controls
Energy efficient	Approximately 84% of the heat created goes directly towards heating cookware contents
Cool surface	Since heat is created inside the cookware, most is confined to the pot and its contents, keeping the surface fairly cool to touch
Automatic pan recognition	Interior coil turns off after 30 seconds if there is no induction cookware on top
Timer	Program to keep track of cooking time
Easy cleanup	With no baked-on messes, all you need is a damp cloth to wipe down the surface

Specifications:

Height	3.88"
Width	12.88"
Depth	16.75"
Shipping Weight	13.2 lbs.
Other Energy Info	1800W
Voltage/Frequency	115 V AC/60 Hz
US Electrical Safety	UL
Surface Type	Glass
Number of Burners	1
Burner Type	Glasstop
Burner Temperature Control	Digital
Heating Type	Induction
Parts/Labor Warranty	1 Year
Sanitation	ETL-S

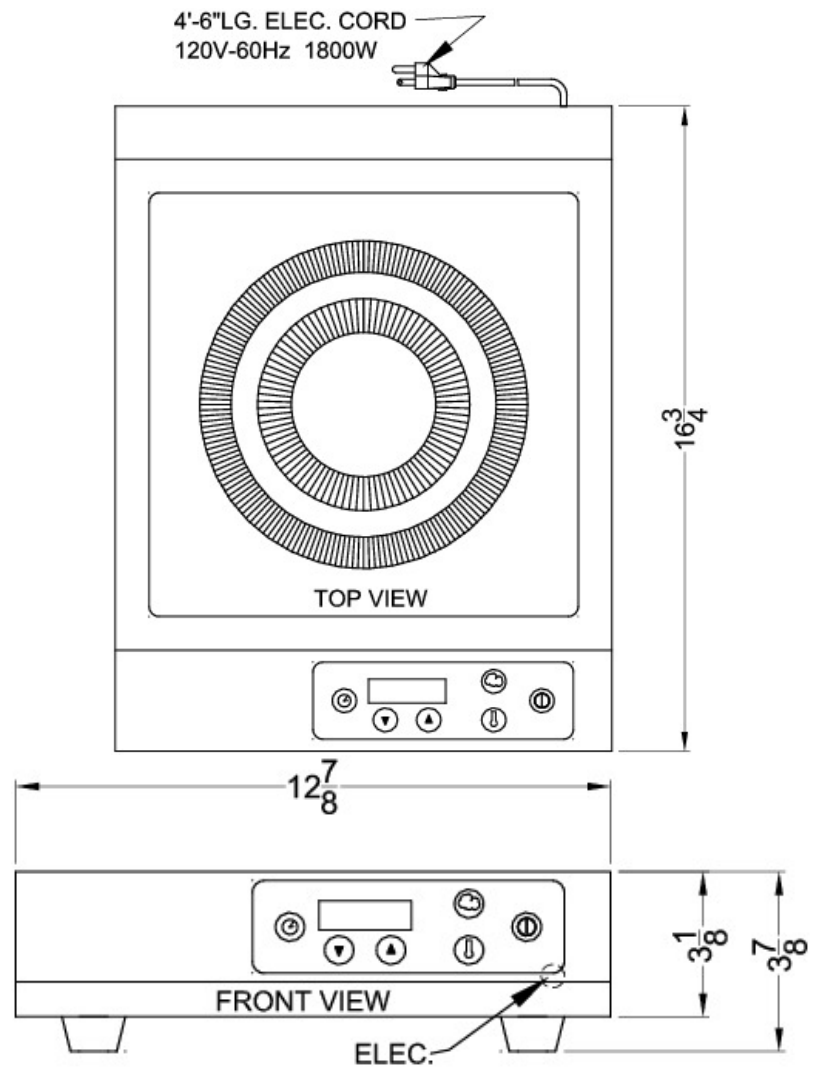

Summit Appliance Division, Felix Storch, Inc.
 770 Garrison Ave • Bronx, NY 10474
 Phone: 718-893-3900 • Fax: 718-842-3093
 Email: info@summitappliance.com