

24" Bar Handle Dishwasher

800 Plus Series- Stainless steel

SHX5ER55UC



Features and Benefits

Key Features

- 46 dBA- Quietest dishwasher in it's class
- 3rd Rack for Additional Loading Capacity
- ActiveTab™ Tray Optimizes Detergent Dissolving
- Water Softener Ensures Perfect Cleaning Results
- AquaStop® Plus 4-Part Leak Protection Works 24/7
- Saves up to 599 gallons of water each year

Design

- Stainless Steel TallTub
- Real Stainless Steel Fascia Panel
- Red Remaining Time Display

Performance

- 46 dBA- Quietest dishwasher in it's class
- 4 Wash Cycles and 2 Options
- Sanitize Option eliminates bacteria and enhances drying results
- Variable Spray Pressure
- ActiveTab™ Tray Optimizes Detergent Dissolving
- Water Softener Ensures Perfect Cleaning Results

Efficiency

- Saves up to 599 gallons of water each year
- 259 kwh/yr - Energy Star®
- Exceeds ENERGY STAR Requirements by 35%
- EcoSense™ Reduces Energy Usage by up to 20%
- Half Load Option for Small Loads

Convenience

- AquaStop® Plus 4-Part Leak Protection Works 24/7



Notes: All height, width and depth dimensions are shown in inches. *Please refer to installation instructions prior to making cutout. BSH reserves the absolute and unrestricted right to change product materials and specifications, at any time, without notice. Consult the product's installation instructions for final dimensional data and other details. Applicable product warranty can be found in a accompanying product literature or you may contact your account manager for further details.

For more information on our entire line of products, go to boschappliances.com or call 1-800-944-2904.

Copyright ©2014 BSH Home Appliances Corporation. All rights reserved. Bosch is a registered trademark of Robert Bosch GmbH.

Litho Date: 03/2014



24" Bar Handle Dishwasher 800 Plus Series- Stainless steel SHX5ER55UC

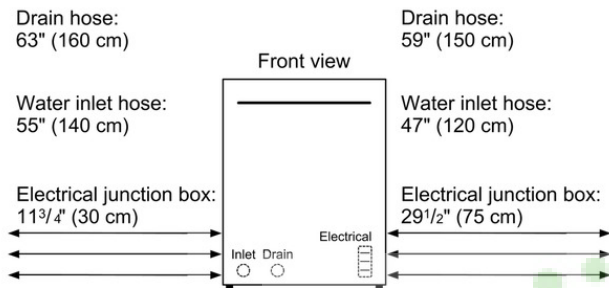

All connections are at the rear of the appliance.
Extension for drain hose available as accessory.
Power cord for connection to electrical outlet (3-prong plug) available as accessory.

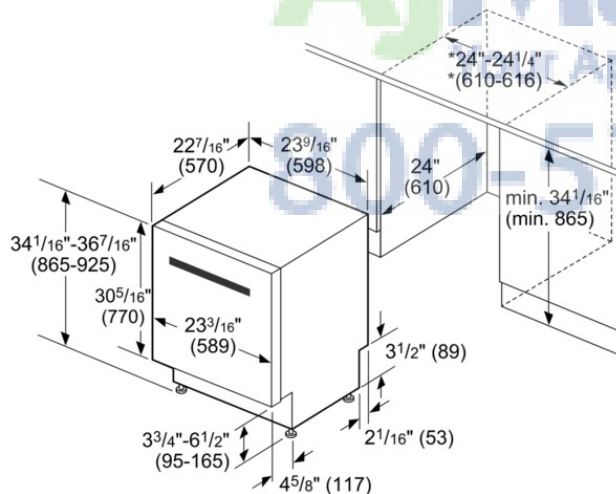

*23⁵/₈" (600) without decor strips

measurements in inches (mm)

Features

Watts (W)	1300
Current (A)	12
Volts (V)	120
Frequency (Hz)	60
Power Cord Length	47 1/4"
Minimum Water Pressure (lb/sin)	7.0
Length inlet hose (in)	55 1/8"
Length outlet hose (in)	55 1/8"
Overall appliance dimensions (HxWxD) (in)	34 1/16" x 23 9/16" x 22 7/16"
Required cutout size (HxWxD) (in)	34 1/8" x 24" x 24"
Adjustable feet	Yes

Technical Specification

Number of wash cycles	3
Number of options	5
Third Rack	3rd Rack 1.0
Tub material	Stainless steel
Concealed heating element	Yes
Leak protection system	24/7 Aqua Stop Plus
Five-level wash	Yes
Water softener	Yes
ChildLock	No
Total annual energy consumption (kWh)	259
Energy Efficiency Class	Tier 1
Energy Star® qualified	Yes
Total annual energy consumption (kWh)	537.5
Total annual water consumption (g)	538
Number of place settings	14

Notes: All height, width and depth dimensions are shown in inches. *Please refer to installation instructions prior to making cutout. BSH reserves the absolute and unrestricted right to change product materials and specifications, at any time, without notice. Consult the product's installation instructions for final dimensional data and other details. Applicable product warranty can be found in a accompanying product literature or you may contact your account manager for further details.

For more information on our entire line of products, go to boschappliances.com or call 1-800-944-2904.

Copyright ©2014 BSH Home Appliances Corporation. All rights reserved. Bosch is a registered trademark of Robert Bosch GmbH.

Litho Date: 03/2014

