

24" Multi-function Convection Oven
 EAN13: 8017709268459

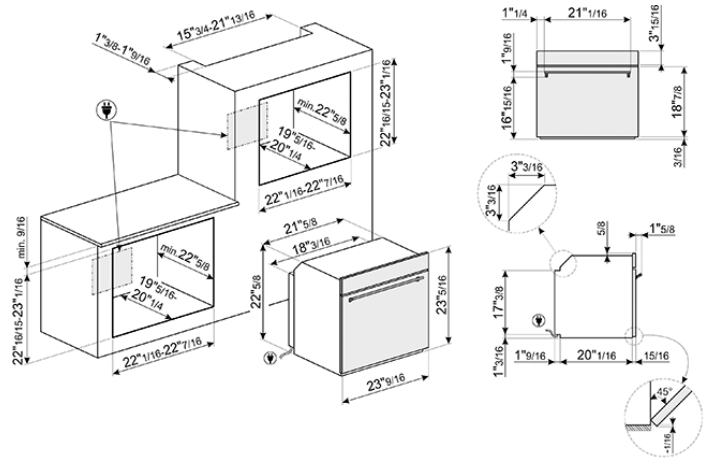

- **AESTHETIC** • **Classic Design** • Fingerprint-proof stainless steel and "Smart-black" glass • **Large LCD display** • **TECHNICAL SPECIFICATIONS** • Multi-function oven with 9 cooking modes • **20 automatic cooking programs** • Electronic temperature control, with ergonomic knobs • **Soft-closing door** • **True European convection** • Rapid pre-heating • **"Vapor-Clean" system** • "Ever-Clean" enamel cavity for quick and easy cleaning • Air-cooled, quadruple-glazed removable door ("Safe touch") • 5 rack positions • 2 halogen lights • **Sabbath mode** • Child lock • Bake element: 1,200 W • Grill element: 2,700 W • Circular heating element: 2,000 W • **GENERAL SPECIFICATIONS** • Oven dimensions (HxWxD): 23 5/16" x 23 9/16" x 22 9/16" (handle excluded) • Oven capacity: 2.8 cu. ft. • **ELECTRICAL SPECIFICATIONS** • Voltage rating: 240/120V - 60Hz • Nominal power: 3 kW • Current: 14 A • **INCLUDED ACCESSORIES** • 1 x partial-extraction telescopic guide rails • 1 x oven rack with side- and back-stop • 1 x oven rack for trays • 1 x enameled tray (0.8") • 1 x enameled tray (1.6") •



Functions

