

SCP111BU2



Single Oven, 60 cm (approx. 24"),
White

Modern exclusive Linear design
Ergonomic backlit transparent controls
Stainless steel and Stopsol® "Supersilver"
glass
Digital electronic program feature with multidisplay

Multifunction oven with 11 cooking modes
+ self cleaning cycle

Dual digital display for time and temperature
Electronic temperature control
Temperature range 104°F - 536°F
Fast pre-heating for all temperatures
Self-cleaning system
Automatic door lock during self cleaning
cycle
Double insulation of the cavity
Fumes control with ceramic catalyst
Safe cooler door
Quadruple glazed removable door
Quickly removable, easy to clean inner
door glass
Automatic oven switch-off when door is
open

Oven capacity: 2.23 Cu.Ft.
Usable oven capacity: 1.9 Cu.Ft.
Interior dimensions: W 17 ½" x H 12" x D
15 13/16"
Bake element: 1300W at 240V - 1100W
at 208V
Broil element: 2000W at 240V - 1600W
at 208V
Convection element: 2200W at 240V -
1800W at 208V

Voltage rating: 240/208V - 60Hz
Connected load (nominal power): 240/208V-
3.5/2.6kW

Amps @ 240/208V: 14.6/12.5
Power supply location: Back right bottom

ACCESSORIES INCLUDED:

- 1 Baking tray
- 1 Baking/Broiler tray
- 1 broiler rack
- 2 Wire racks
- 1 Rotisserie kit

FUNCTIONS



VERSIONS

- SCP111U2 - Stainless steel
- SCP111SU2 - Silver
- SCP111NU2 - Black



SCP111BU2



Single Oven, 60 cm (approx. 24"), White

	ECO	<p>ECO: The Eco setting is a fast preheat function, which combines broil, fan and lower element to achieve optimum energy efficiency. Only to be used prior to selecting the main cooking mode.</p>
		<p>Top and bottom heat: This method is known as "conventional" cooking, and is suitable for dishes that require a more gentle heat, such as baking. The oven needs to be pre-heated to the required temperature, and is best suited for single items, such as large cakes. Best results are obtained by placing food in the centre of the oven.</p>
		<p>Rotisserie with broil: The rotisserie (where installed) works in combination with the broil element to brown foods to perfection.</p>
		<p>Intensive broil: This allows rapid cooking and browning of foods. Best results can be obtained from using the top rack for small items, the lower racks for larger items, such as chops or sausages. Cooking using this method should be carried out with the door closed, unless instructed to do otherwise.</p>
		<p>Convection with top and bottom heat: The elements combined with the fan aim to provide more uniform heat. This is a similar method to conventional cooking, so pre-heat is required. This is not as effective as european convection cooking but can be used to cook biscuits and pastry.</p>
		<p>Convection with intensive broil: The combination of the fan and top element provides more uniform heat penetration. Dishes are lightly browned on the outside and still moist on the inside. Ideal for au gratin dishes, finishing roasted vegetables.</p>
		<p>Convection with bottom heat: This combination quickly completes the cooking of foods that are ready on the surface, but require more cooking inside, without further browning. Suitable for any type of food.</p>
		<p>European convection: The combination of the fan and circular element around it, gives uniform heat distribution with no cold spots. This has benefits - no preheat if cook time is more than 20 minutes, no flavour transfer when cooking different foods the same time, less energy is needed, and it cooks at 10% quicker than a normal oven.</p>
		<p>European convection with top and bottom heat: The use of the fan with both elements allows food to be cooked quickly and effectively on a number of oven racks. Ideal for roasts that require thorough cooking. There is no transference of smells or flavours when using this function. This function offers a similar result to rotisserie, it moves the heat around the food, instead of moving the food itself, enabling any size or shape to be cooked, and not only items that will fit onto a rotisserie.</p>
		<p>Defrost: The circulation of air at room temperature enables quicker thawing of frozen food, (without the use of any heat). Ideal for use prior to cooking of readymade dishes, or cream filled products etc.</p>
		<p>Bread Proving: Air at 104°F provides the perfect environment for proving yeast type dough mixes. Simply select the function and place dough in the oven for allotted time.</p>
		<p>Self-cleaning system: The self cleaning system cleans at 932°F destroying all the dirt deposits inside the oven.</p>

SCP111BU2



Single Oven, 60 cm (approx. 24"),
White

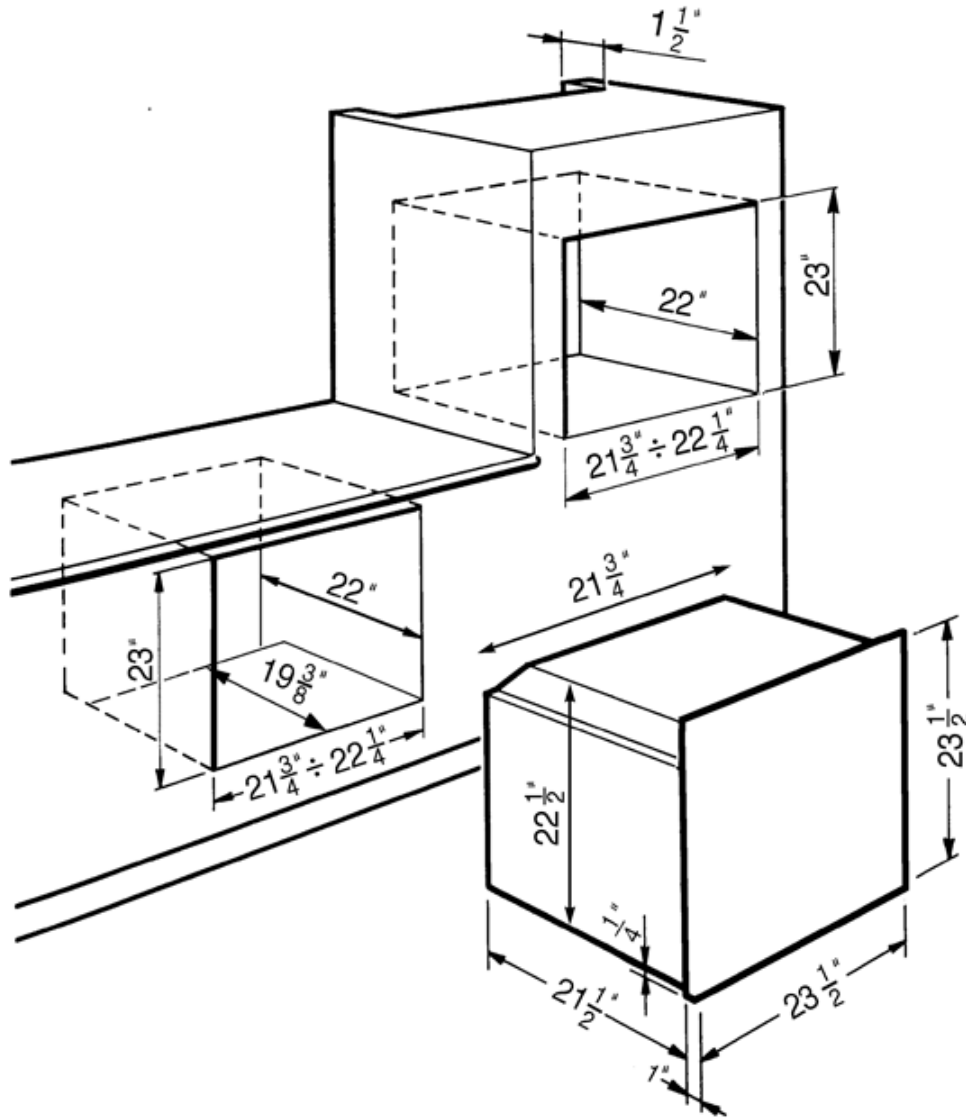

SMEG USA INC.
A&D BUILDING
150 EAST 58th STREET
7th FLOOR
NEW YORK, NY, 10155