

**SCFF53BSS**

34.0" x 23.63" x 23.5" (H x W x D)

Frost-free built-in undercounter all-freezer for residential or commercial use, with digital thermostat, stainless steel door, lock, and black cabinet

**Highlights:**

True frost-free operation saves you maintenance by preventing icy buildup

Flexible design allows built-in or freestanding use in 24" wide spaces

Digital thermostat allows easy temperature management

Factory-installed lock offers security you can count on



**AjMadison**  
Your Appliance Authority™  
800-570-3355

Frost-free operation	No-frost convenience eliminates the need to manually defrost the unit
Built-in capable	Make the best use of space by installing your freezer under the counter and flush with other cabinets
Stainless steel door	Durable construction with a professional look
Digital thermostat	Electronic controls offer easy and intuitive temperature management
Recessed LED light	Elegant lighting with an on/off switch located on the control panel
Reversible door	User-reversible door swing for added flexibility
Adjustable shelves	Rearrange your freezer space to accommodate all shapes and sizes or remove shelves for a simple clean-up
Factory installed lock	Keyed lock for a secure interior
Professional handle	Attractive chrome handle adds a touch of modern style
Open door alarm	Audible alarm will sound if the door is left open longer than one minute

## SCFF53BSS Specifications:

Height	34.0"
Width	23.63"
Depth	23.5"
Capacity	4.72 cu.ft.
Ext Depth with Handle	25.35"
Interior Height 1	26.0"
Interior Width 1	19.0"
Interior Depth 1	16.0"
Shipping Weight	98.0 lbs.
Weight	88.0 lbs.
Canadian Electrical Safety	ETL-C
Energy Usage/Year	390.0 kWh/year
US Electrical Safety	ETL
Voltage/Frequency	115 V AC/60 Hz
Amps	0.9
Reversible	Yes
Door Swing	RHD
Shelf Quantity	3
Adjustable Shelf	true
Shelf Type	Chrome
Defrost Type	Frost-Free
Depth with door at 90°	45.63"
Light	true
Thermostat Type	Digital
Fan Type	Interior and Exterior
Low Side PSI	105.0
Refrigerant Type	R600a
Freon Oz	1.24
High Side PSI	270.0
Compressor Warranty	5 Years
Parts/Labor Warranty	1 Year
Sanitation	ETL-S

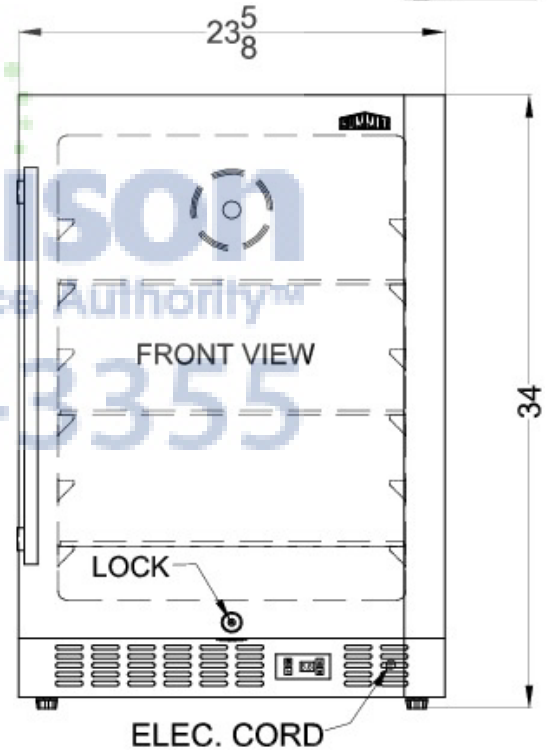
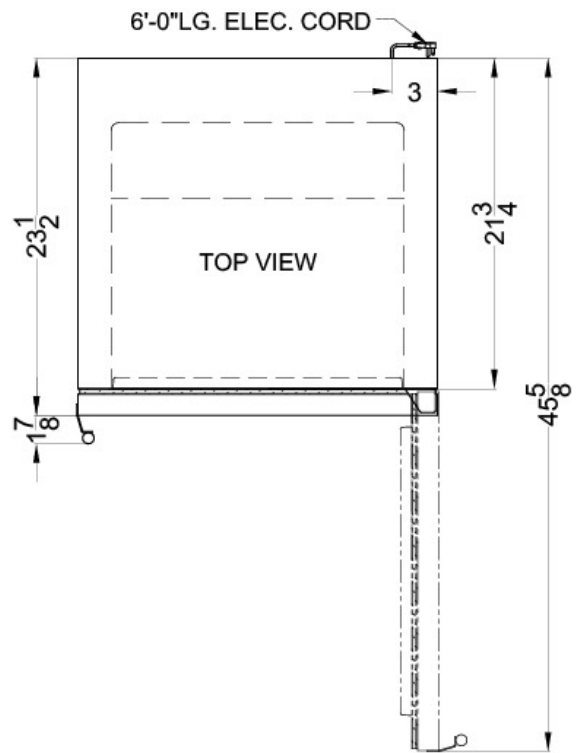

**AjMadison**  
Your Appliance Authority™  
800-570-3355

Summit Appliance Division, Felix Storch, Inc.  
770 Garrison Ave • Bronx, NY 10474  
Phone: 718-893-3900 • Fax: 718-842-3093  
Email: info@summitappliance.com