



SUMMERSET

PROFESSIONAL GRILLS

30" - Builder Grill

Model	SBG30
Cutout Dimensions**	28.5"W x 10.1875"H x 23.0625"D
Actual Dimensions	30"W x 25.5"H x 27"D
Material	#443 Stainless Steel
Burner Count	2 Main Burner
Total BTU	52,000 BTU
Total Cooking Surface	541 sq. in.
Electical Supply	N/A
Gas Inlet NG	3/8" NPT Female Regulator
Gas Inlet LP	3/8" NPT Male Fitting
Power Cord Length	N/A

NOTES

Front

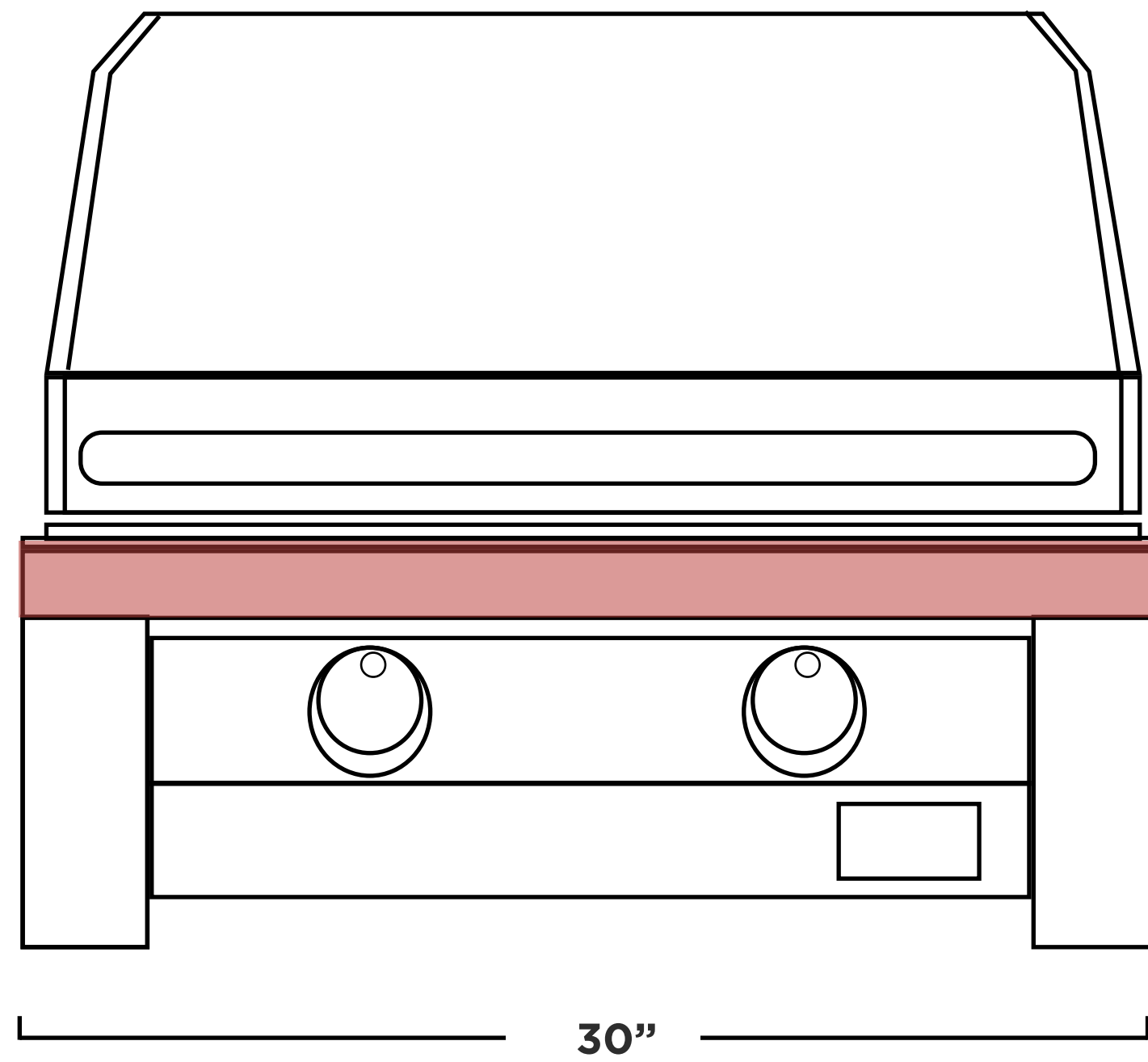

Rear

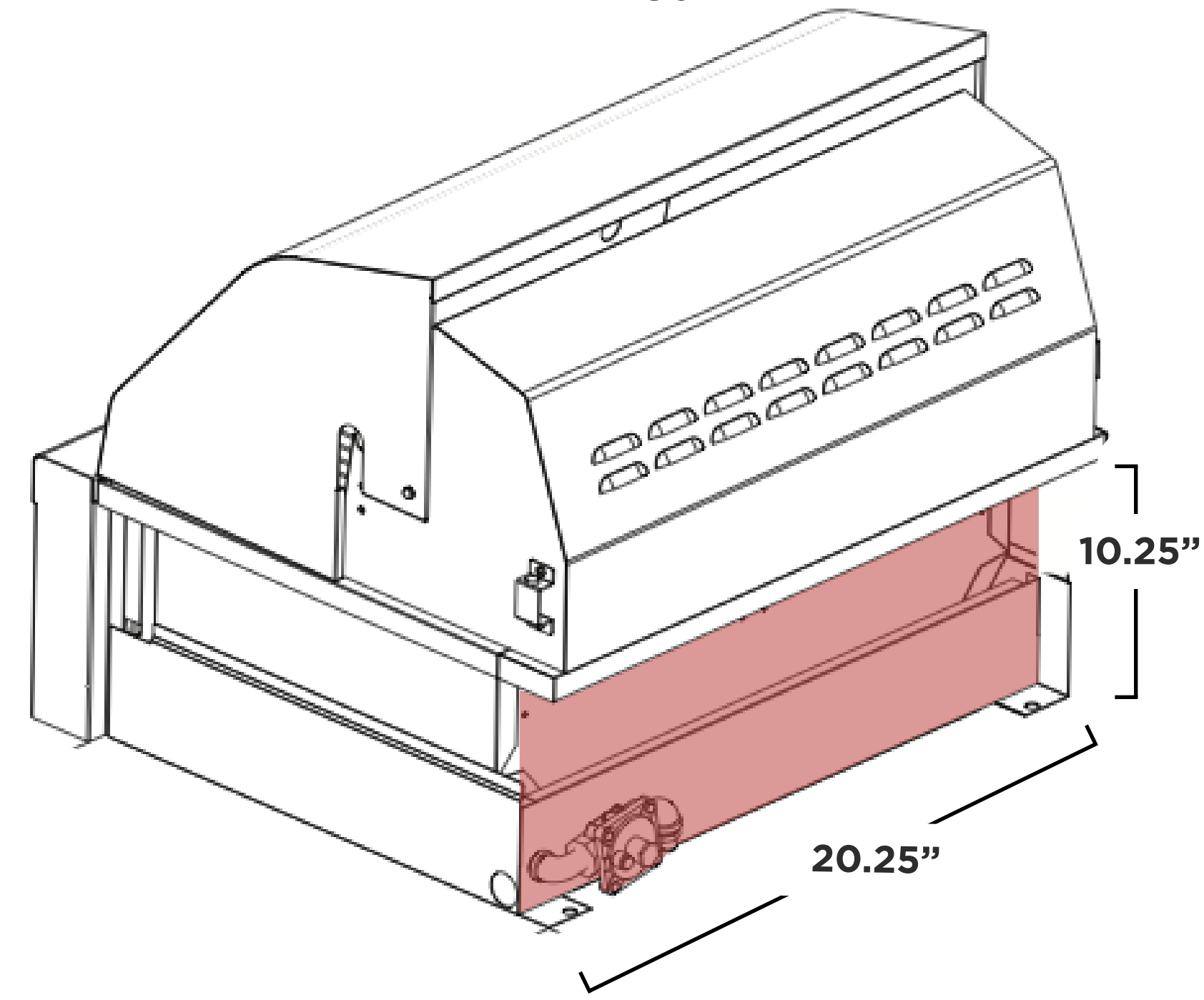

Side

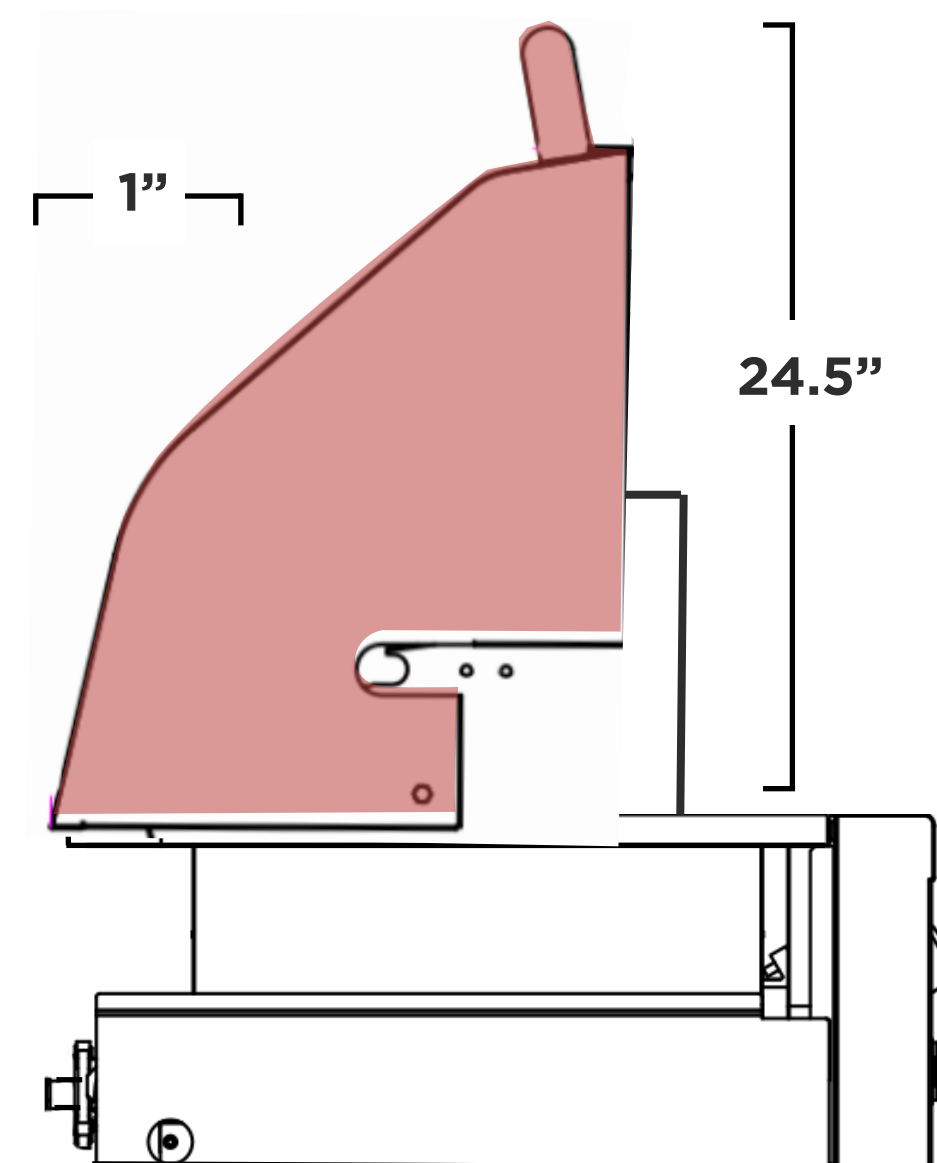
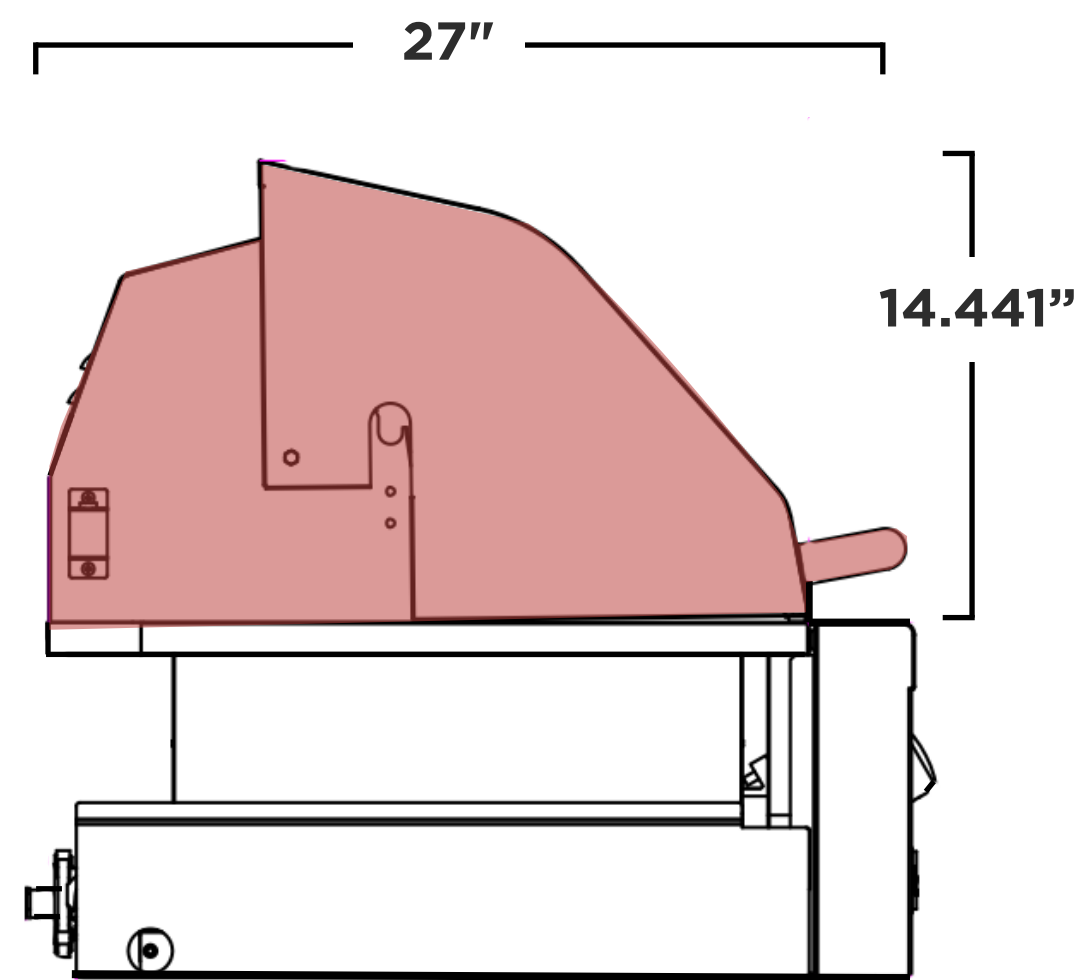
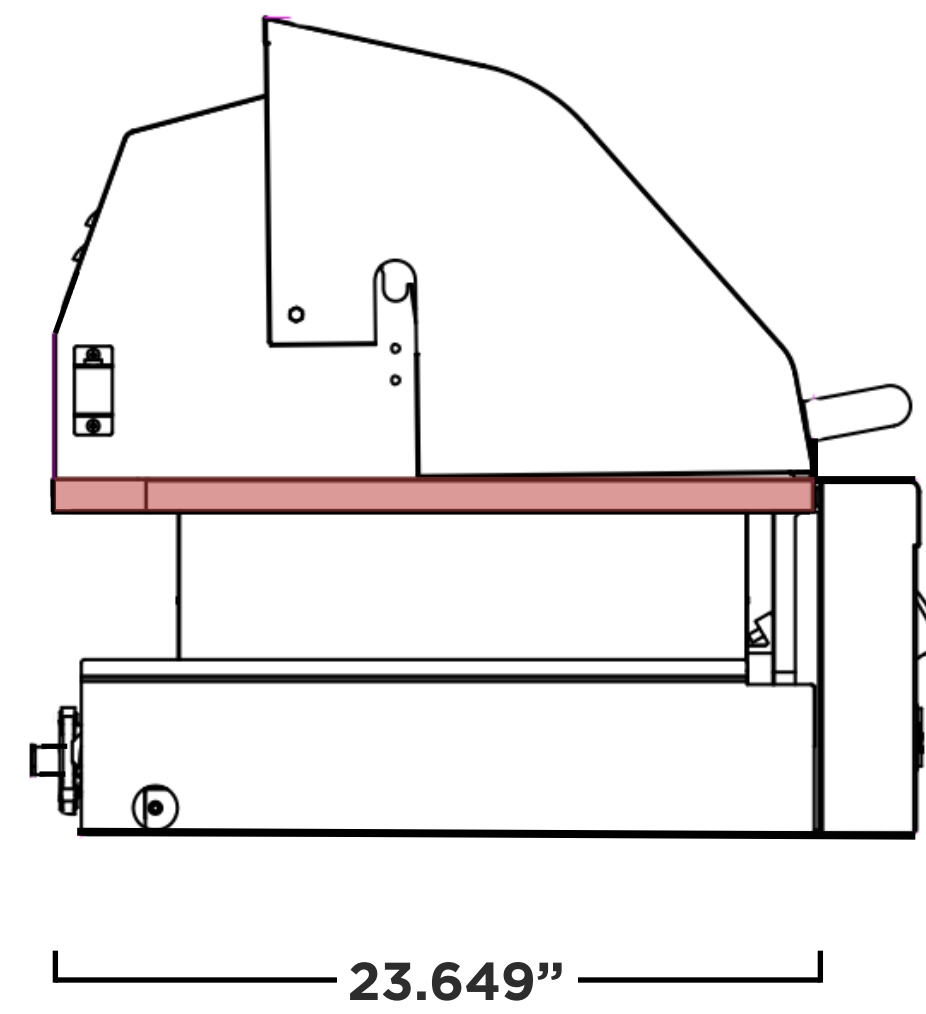
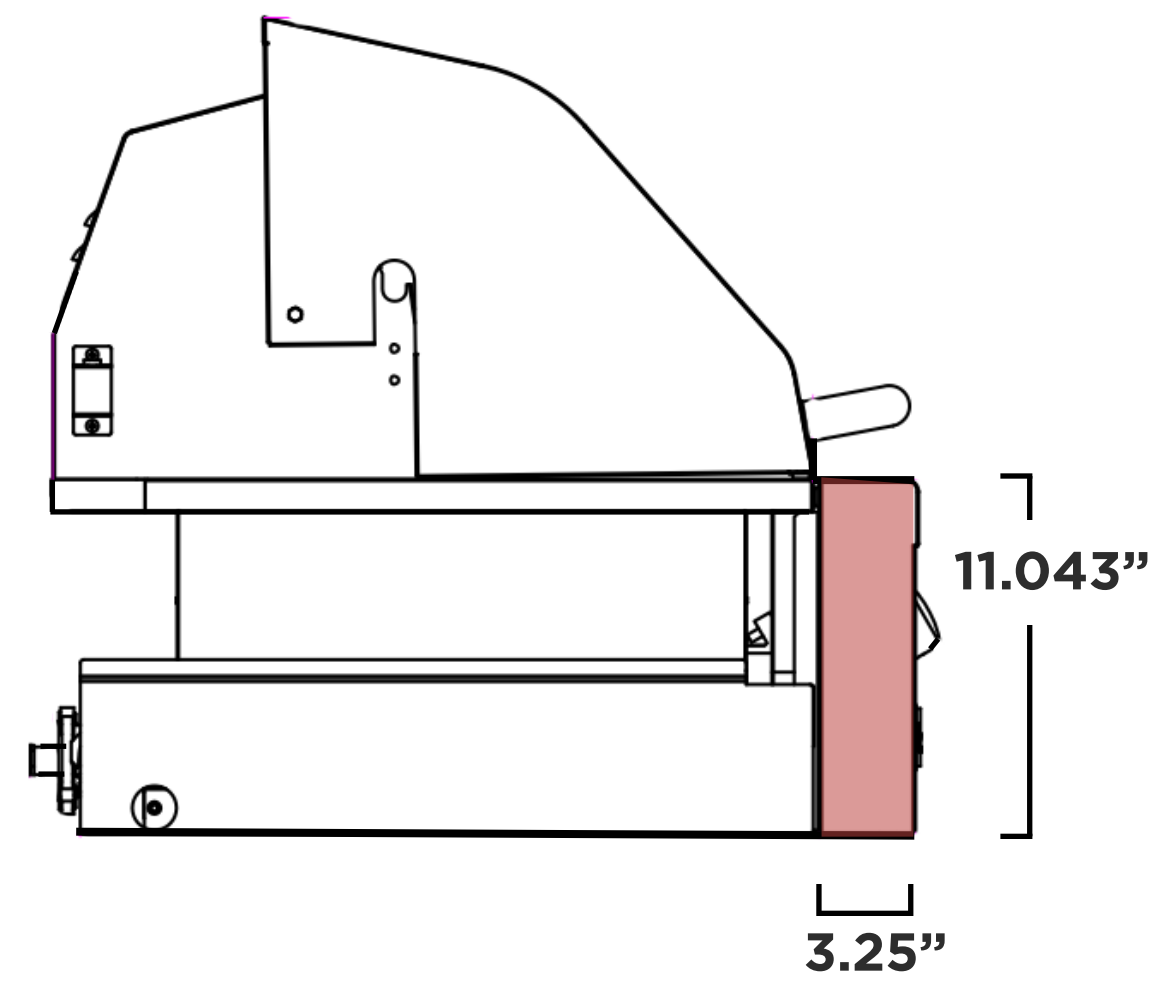
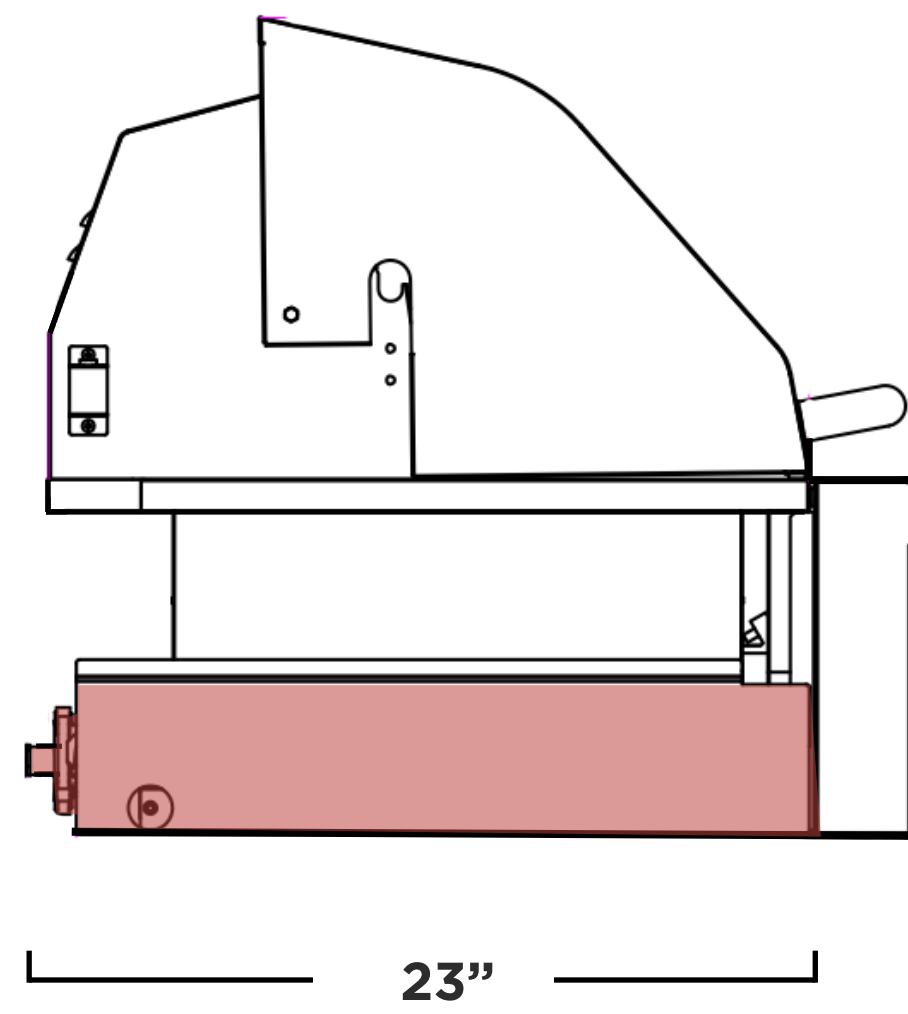

Cutout Dimensions **
28.5"W x 10.1875"H x 23.0625"D

Island Top View

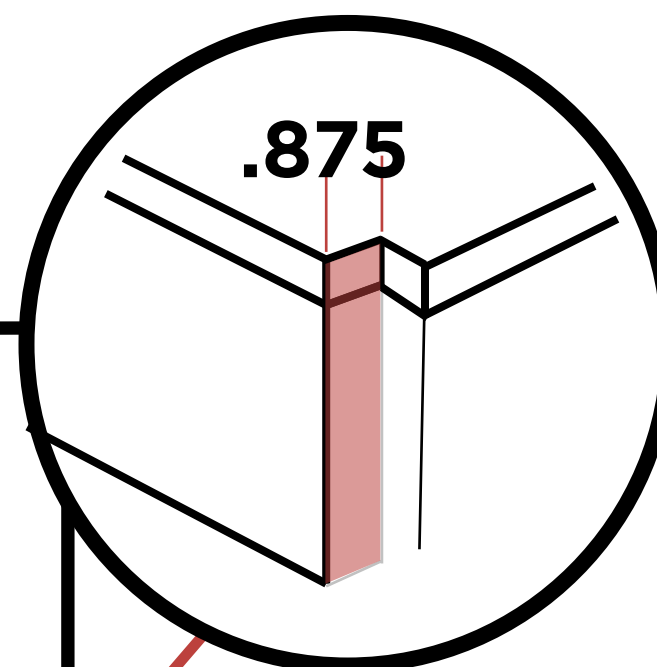
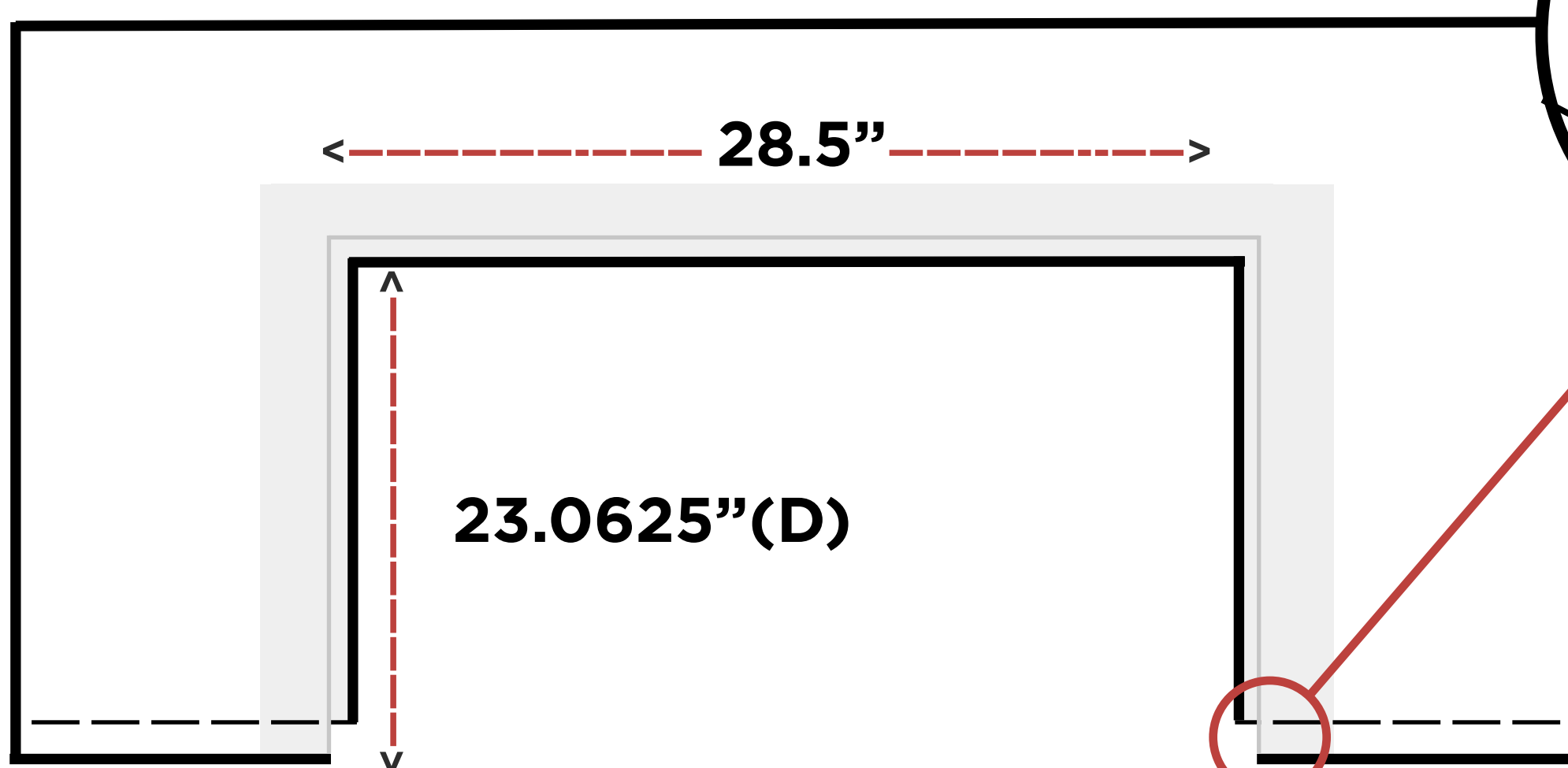

Countertop Notch
Cutout Dimension

Island Front View

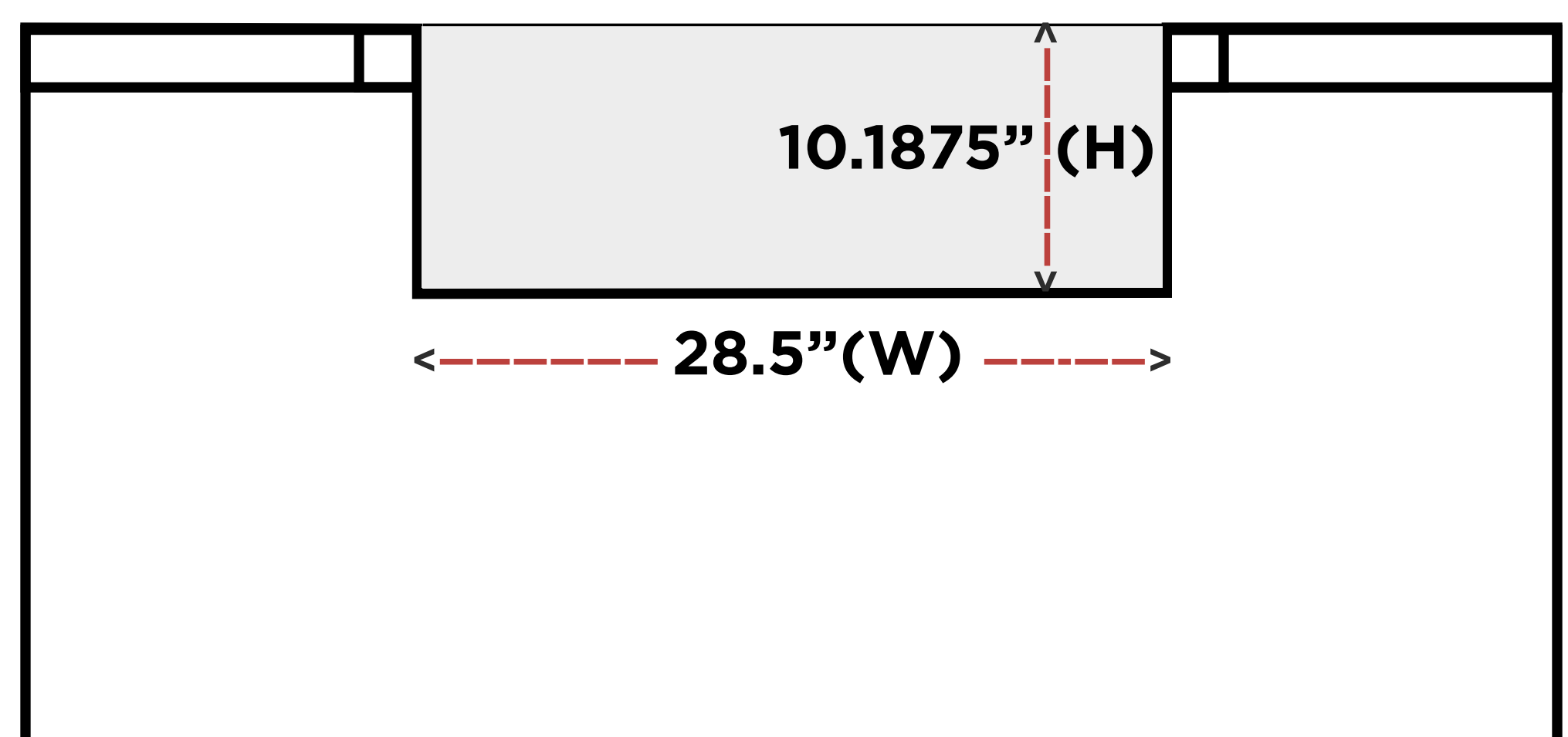

Manufacturer Suggested Cutout Dimensions ()**