

SBC590

34.38" x 23.75" x 24.38" (H x W x D)

Built-in frost-free beer dispenser with dual tap system for two 1/6 kegs

Highlights:

Fully frost-free interior for low maintenance operation

Twin tap system lets you serve your favorite drafts from two 1/6 kegs

Designed for built-in installation under counters

Stainless steel wrapped door includes professional handle mounted horizontally for a modern look



AjMadison
Your Appliance Authority
800-570-3355

Built-in capable	Front-breathing design allows fully recessed installation under counters
Frost-free operation	No-frost operation for minimum user maintenance
Stainless steel door	Fully wrapped 304 grade stainless steel door offers lasting durability and style
Professional horizontal handle	Sleek stainless steel handle is mounted horizontally for a modern look
Reversible door	User reversible door swing for added placement flexibility
Complete tap kit	Includes a 5 lb. CO2 tank and regulator, draft arm, dual Sankey American tap, connection hardware, and cleaning kit
Dual tap system	Interior accepts two 1/6 kegs to accommodate all tastes
Adjustable thermostat	Front-located thermostat allows easy temperature management
Stainless steel drip tray	Two-piece drip tray included to help catch spills
Sealed back	Space saving design with easier cleanability

SBC590 Specifications:

Height	34.38"
Width	23.75"
Depth	24.38"
Capacity	5.7 cu.ft.
Ext Depth with Handle	25.75"
Interior Height 1	27.5"
Interior Width 1	20.75"
Interior Depth 1	17.25"
Comp Step Height	4.0"
Comp Step Width	20.75"
Comp Step Depth	6.0"
Shipping Weight	180.0 lbs.
Weight	153.0 lbs.
Canadian Electrical Safety	ETL-C
Amps	1.3
Voltage/Frequency	115 V AC/60 Hz
US Electrical Safety	ETL
Reversible	Yes
Door Swing	RHD
Defrost Type	Frost-Free
Depth with door at 90°	47.0"
Height to Hinge Cap	34.75"
Thermostat Type	Dial
Fan Type	Interior and Exterior
High Side PSI	235.0
Low Side PSI	140.0
Refrigerant Type	R134a
Freon Oz	3.5
Parts/Labor Warranty	1 Year
Compressor Warranty	5 Years

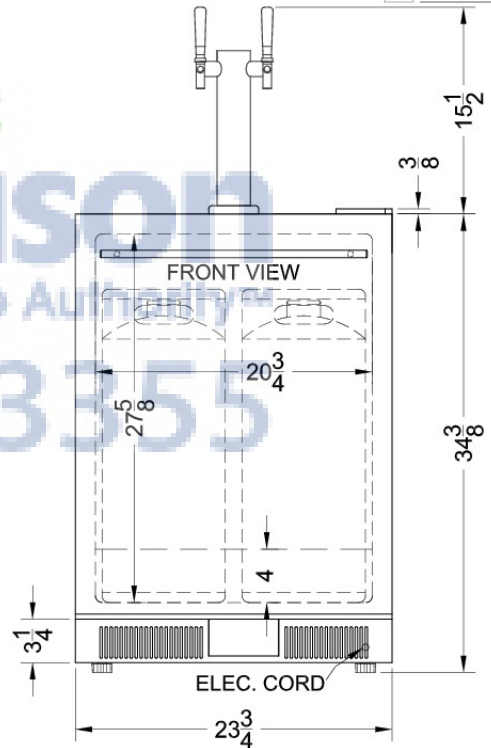
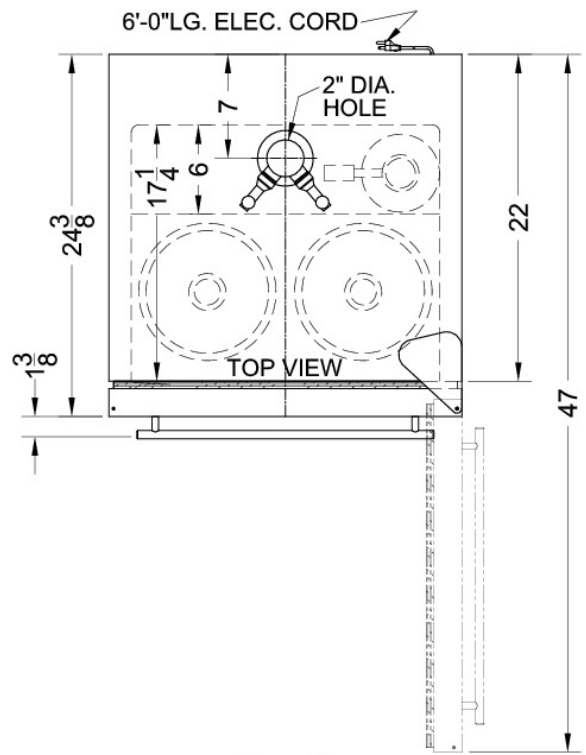

AjMadison
Your Appliance Authority
800-570-3355

Summit Appliance Division, Felix Storch, Inc.
770 Garrison Ave • Bronx, NY 10474
Phone: 718-893-3900 • Fax: 718-842-3093
Email: info@summitappliance.com