

S2951CXU



Ceramic Cooktop, 90 cm (approx. 36"),
Stainless Steel Frame

5 High-Light radiant zones:

Front right: 1,200 W - @ 5 1/2" (140mm)

Back right: 2,000 W - @ 7 5/8" (195mm)

Central: 750 + 900 + 1,050 W - @ 5 1/2" - 8 1/4" -
10 5/8" (140-210-270mm)

Front left: 800 + 1,200 W - @ 4 3/4" - 7" (120-180mm)

Back left: 1,200 W - @ 5 1/2" (140mm)

Elegant stainless steel frame

"Suprema" black ecological glass

Soft touch controls

5 high-light radiant elements, including 2 variable
zones (central high speed zone with three level
adjustment)

9 power levels for each zone

Residual heat indicator for each zone

Automatic safety cut-out

Individual timer for each zone (1 - 99min)

Safety lock device

ACCESSORIES INCLUDED:

1 Cleaning scraper

Voltage rating: 240/208V - 60Hz

Connected load (nominal power): 240/208V-
8.6/6.5kW

Amps @ 240/208V: 36/32

Electrical - single phase 3 or 4 wire cable

required, 120/240V or 120/208V, 60Hz, fused on
both sides of line with ground.



**SMEG USA INC.
A&D BUILDING
150 EAST 58th STREET
7th FLOOR
NEW YORK, NY, 10155**

S2951CXU



Ceramic Cooktop, 90 cm (approx. 36"),
Stainless Steel Frame

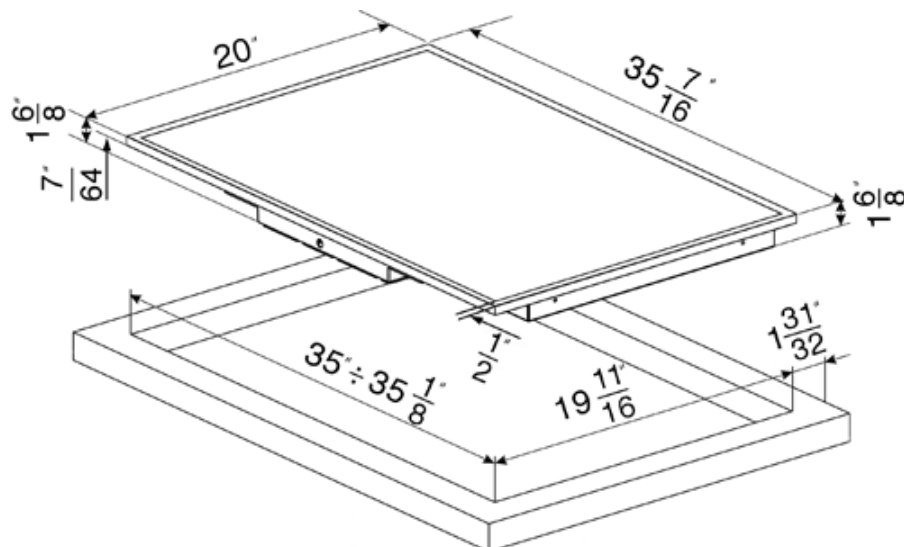

SMEG USA INC.
A&D BUILDING
150 EAST 58th STREET
7th FLOOR
NEW YORK, NY, 10155