

S19LWH

19.75" x 17.75" x 17.63" (H x W x D)

Compact refrigerator-freezer with front-mounted lock for general purpose use; replaces S19L

Highlights:

Designed for general purpose use in medical and scientific facilities

Factory-installed lock provides security you can depend on

Compact size is ideal for countertop use

Reversible door offers flexible placement



AjMadison
Your Appliance Authority
800-570-3355

Factory installed lock	Keyed lock ensures a secure interior
Reversible door	User-reversible door swing allows for more flexibility in placing the unit
Manual defrost	Static cooling system
Door storage	Store large bottles right on the door for easy access
Adjustable thermostat	Dial thermostat conveniently located on the door to the freezer compartment for easy temperature management
Removable shelf	Wire shelf included for storage convenience
Compact dimensions	Sized for easy use on top of counters
100% CFC free	Environmentally friendly design without ozone-damaging chemicals

Specifications:

Height	19.75"
Width	17.75"
Depth	17.63"
Capacity	1.7 cu.ft.
Interior Height 1	16.13"
Interior Width 1	14.88"
Interior Depth 1	14.25"
Interior Height 2	4.38"
Interior Width 2	8.75"
Comp Step Height	7.38"
Comp Step Width	14.88"
Comp Step Depth	6.0"
Shipping Weight	50.0 lbs.
Weight	31.0 lbs.
Canadian Electrical Safety	ETL-C
Amps	0.78
US Electrical Safety	ETL
Voltage/Frequency	115 V AC/60 Hz
Reversible	Yes
Door Swing	RHD
Shelf Quantity	1
Adjustable Shelf	true
Shelf Type	Wire
Full Door Shelf Quantity	1
Half Door Shelf Quantity	1
Defrost Type	Manual
Depth with door at 90°	33.88"
Height to Hinge Cap	20.13"
Thermostat Type	Dial
Condensor Location	N/A
Low Side PSI	110.0
High Side PSI	250.0
Refrigerant Type	R134a
Freon Oz	1.13
Compressor Warranty	5 Years
Parts/Labor Warranty	1 Year

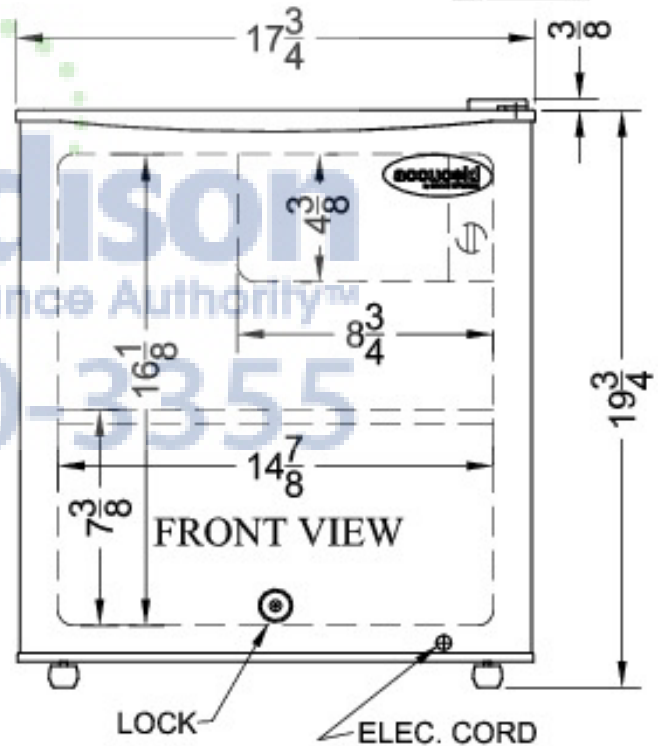
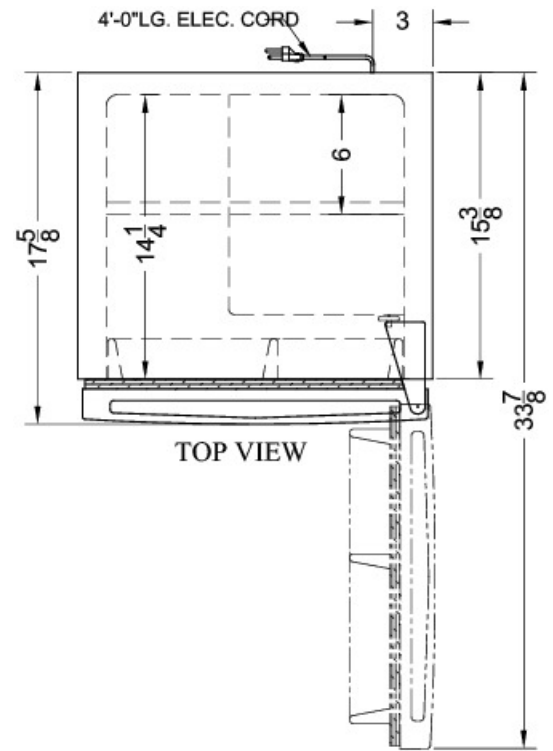

Summit Appliances Division, Felix Storch, Inc.
 770 Garrison Ave • Bronx, NY 10474
 Phone: 718-893-3900 • Fax: 718-842-3093
 Email: info@summitappliance.com