

**S19LWHPLUS**

19.75" x 17.75" x 17.63" (H x W x D)

Compact refrigerator-freezer with thermometer, hospital grade cord, and front-mounted lock for general purpose use; replaces S19LPLUS

**Highlights:**

Designed for general purpose use in medical and scientific facilities

Traceable thermometer provides external readout of current and high/low temperature

Includes hospital grade cord with a 'green dot' plug

Factory installed lock provides security you can count on



**AjMadison**  
Your Appliance Authority  
800-570-3355

Traceable thermometer	Thermometer provides external readout of current and high/low temperatures
Hospital grade cord with 'green dot' plug	Secure three-pronged cord for added unit safety
Factory installed lock	Keyed lock ensures a secure interior
Manual defrost	Static cooling system for improved temperature stability
Door storage	Store items right on the door for easy access
Adjustable thermostat	Dial thermostat conveniently located on the door to the freezer compartment for easy temperature management
Removable shelf	Wire shelf included for storage convenience
Compact dimensions	Sized for easy use on top of counters
100% CFC Free	Environmentally friendly design with no ozone-damaging chemicals

## Specifications:

Height	19.75"
Width	17.75"
Depth	17.63"
Capacity	1.7 cu.ft.
Interior Height 1	16.13"
Interior Width 1	14.88"
Interior Depth 1	14.25"
Interior Height 2	4.38"
Interior Width 2	8.75"
Comp Step Height	7.38"
Comp Step Width	14.88"
Comp Step Depth	6.0"
Shipping Weight	60.0 lbs.
Weight	31.0 lbs.
Canadian Electrical Safety	ETL-C
Amps	0.78
US Electrical Safety	ETL
Voltage/Frequency	115 V AC/60 Hz
Reversible	Factory Reversible
Door Swing	RHD
Shelf Quantity	1
Adjustable Shelf	true
Shelf Type	Wire
Full Door Shelf Quantity	1
Half Door Shelf Quantity	1
Defrost Type	Manual
Depth with door at 90°	33.88"
Height to Hinge Cap	20.13"
Condensor Location	N/A
Thermostat Type	Dial
High Side PSI	250.0
Low Side PSI	110.0
Freon Oz	1.13
Refrigerant Type	R134a
Parts/Labor Warranty	1 Year
Compressor Warranty	5 Years

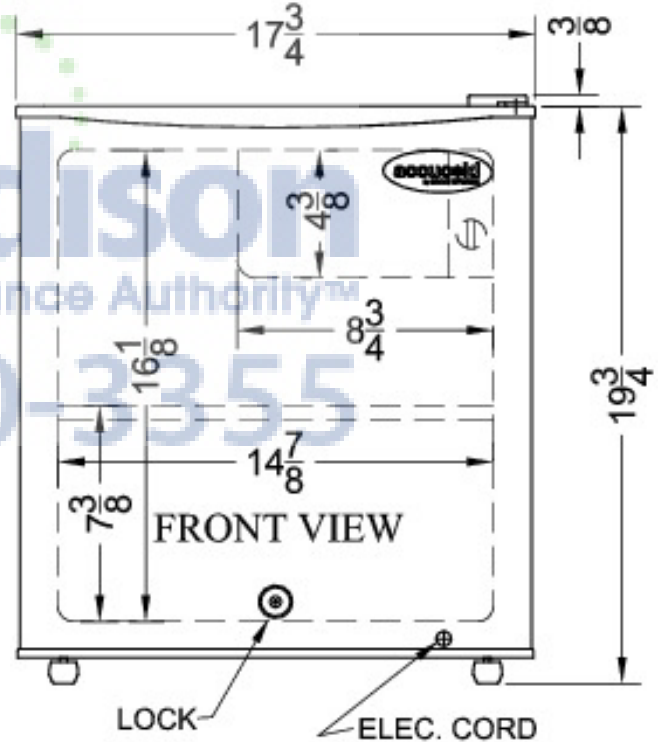
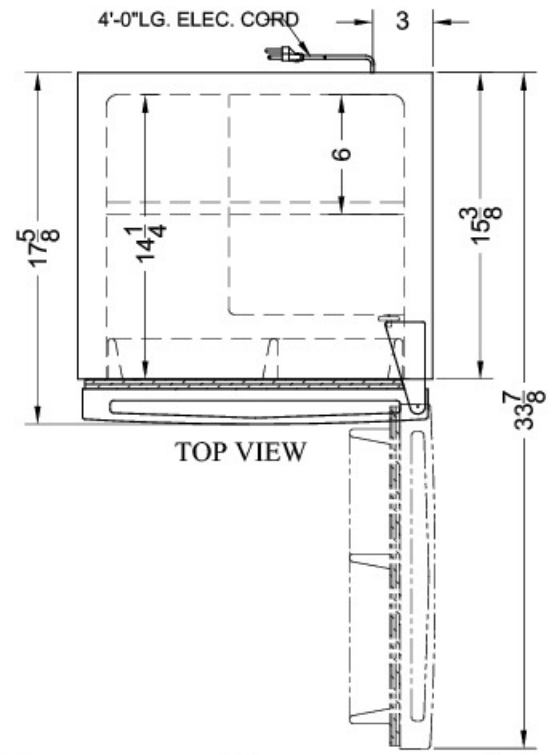

**AjMadison**  
Your Appliance Authority™  
800-570-3355

Summit Appliances Division, Felix Storch, Inc.  
770 Garrison Ave • Bronx, NY 10474  
Phone: 718-893-3900 • Fax: 718-842-3093  
Email: info@summitappliance.com