

# Dual Fuel Range, 48", 4 Burners, 4 Induction Zones, Self-cleaning, LPG

Series 11 | Professional

Stainless Steel | LPG



With both induction and gas cooktops and two convection ovens, you're ready to create a feast - guided by an intuitive touchscreen.

- Guided cooking using your touchscreen makes it simple to cook by food, function or recipe.
- Top burner heat of 19,000 BTU, for seriously fast boiling
- Four induction cooking zones, which can be paired to form two SmartZones

- 6.9 cu ft total oven capacity across two oven cavities

## DIMENSIONS

Height	35 3/4 - 36 3/4"
Width	47 7/8"
Depth	29 1/8"

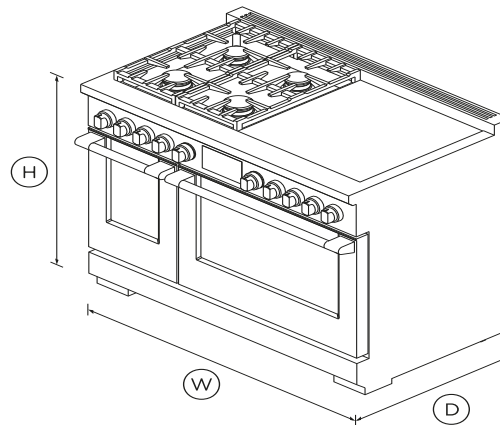

## FEATURES & BENEFITS

### Cook with confidence

Our touchscreen interface provides an intuitive guided cooking experience that helps deliver perfect results, whether you've been cooking all your life or just starting out. Cook with a favorite method, a hero ingredient, or a go-to cooking function or recipe. The screen tilts for improved ergonomics and optimal visibility while cooking.

### Generous capacity

Two independently operating cavities provide a large total capacity of 4.8 cu. ft. in the main cavity and 2.1 cu. ft. in the secondary. That's enough room for a 32 lb turkey in one oven, and your sides in the other.

### Cooking flexibility

No matter what you're cooking, you've got the right heat to get perfect results. Each of the 15 oven functions in the main cavity and 11 in the secondary have been extensively researched and carefully designed to cater to a broad range of dishes and cooking styles. The handy food probe helps you monitor your progress.

### Cooktop power

On the gas side of the cooktop, Sealed dual flow burners deliver power up to 19,000 BTU, while the induction side delivers up to 3700W. This finely tuned cooktop provides instant and immediate control from the highest heat to the most gentle simmer.

### Design quality

This range has craftsmanship in every detail, with real stainless steel, cast-iron trivets, and beautifully weighted, halo illuminated dials. Each cavity features incandescent lights and full extension telescopic racks. From the robust legs to the powerful cooktop, this Range is built to last.

### Easy to clean

The oven features a self-cleaning function and self-clean proof side racks, which don't need to be removed when using this function. The induction zones only need a quick wipe after use to keep them clean.

## SPECIFICATIONS

### Accessories

Square handle option

AH-R48

**Burner ratings**

Maximum burner power	<b>19000 BTU</b>
Power back left	<b>13000BTU</b>
Power back right	<b>13000BTU</b>
Power front left	<b>19000BTU</b>
Power front right	<b>13000BTU</b>
Total cooktop power	<b>58000 BTU</b>

**Capacity**

Shelf positions	<b>5</b>
Shelf positions	<b>5</b>

**Cleaning**

Dishwasher proof grates	•
Pyrolytic self-clean	•

**Controls**

Electric circuit	<b>4 wire</b>
High resolution display	•
Metal illuminated dials	•
Sabbath mode	•

**Gas Requirements**

Fitting and pipe	<b>½ NPT, min. ⅝" flex line</b>
Supply Pressure (LPG)	<b>11" to 14" W.C</b>

**Oven features**

Concealed element	•
Electronic oven control	•
Full extension telescopic	•

Internal light	•
True convection	•

**Oven functions**

True convection	•
-----------------	---

**Oven performance**

Bake power	<b>4600</b>
Broil	<b>3600W</b>
Main oven - True convection	<b>2500W</b>

**Power requirements**

Rated current	<b>50A</b>
Supply frequency	<b>60Hz</b>

**Product dimensions**

Depth	<b>29 1/8"</b>
Height	<b>35 3/4 - 36 3/4"</b>
Width	<b>47 7/8"</b>

**Rangetop features**

Gentle heat	•
Heat settings	<b>9</b>
Induction cooking technology	•
Sealed Dual Flow Burners™	<b>4</b>
SmartZone	<b>2</b>
Vent trim included	•
Zone bridging	•

**Rangetop Performance**

Left front zone rating	<b>2100W (3700W)W</b>
Left rear zone rating	<b>2100W (3700W)W</b>
Number of burners	<b>4</b>
Number of cooking zones	<b>4</b>
PowerBoost	•
PowerBoost all zones	<b>up to 3700W</b>
Right front zone rating	<b>2100W (3700W)W</b>
Right rear zone rating	<b>2100W (3700W)W</b>

**Safety**

ADA compliant	•
Pan detection system	•
Safety time out	•
Surface hot indicators	•

**Secondary oven functions**

Bake	•
Convection bake	•
Convection broil	•
Number of secondary oven	<b>11</b>

**Warranty**

Parts and labor	<b>Limited 2 years</b>
-----------------	------------------------









SKU	<b>81891</b>
-----	--------------

The product dimensions and specifications in this page apply to the specific product and model. Under our policy of continuous improvement, these dimensions and specifications may change at any time. You should therefore check with Fisher &

Paykel's Customer Care Centre to ensure this page correctly describes the model currently available. ? Fisher & Paykel Appliances Ltd 2020

---

**Other product downloads available at fisherpaykel.com**

-  [User Guide](#)
-  [Installation Guide](#)
-  [Specification Guide](#)
-  [Data Sheet Dual Fuel Cooker](#)
-  [Data Sheet Dual Fuel Cooker](#)
-  [Data Sheet Dual Fuel Cooker](#)
-  [Data Sheet Dual Fuel Range](#)
-  [Planning Guide](#)



**A PEACE OF MIND SALE**

**24 Hours 7 Days a Week Customer Support**

**T 1.888.936.7872 W [www.fisherpaykel.com](http://www.fisherpaykel.com)**