



Color Variants

RF411705

Optional accessories

RA448220

Ice storage container, small.

RA450022

Installation Accessories

RA421115

Stainless steel door panel with handle

RA423140

RA425110

Long stainless steel door handle

RA428115

Stainless steel door panel, handleless

RA460012

RA460020

Connecting element for vertically split appliance fronts (for a flush front)

RA464113

Ventilation grill, stainless steel

RF411705

Vario freezer 400 series
Fully integrated, panel ready
Niche width 18" (45.7 cm)
Stainless steel interior with solid anthracite aluminium elements
Warm white and glare-free LED light spots
Opening assist for door with two options: 1. Push-to-open function for integration into handleless furniture front 2. Pull-to-open function to facilitate opening the door using a handle

The drawers in the RC and RF models are positioned at the same level.
With side-by-side installation, the glass shelves and door racks can be aligned on the same level
Material and aesthetics of interior as for RC model - Glass shelves - Solid anthracite aluminium door racks
Flat stainless steel inner door, full-length
Almost invisible rail system for shelves and door racks for flexible positioning
Integrated automatic ice maker with fixed water connection
TFT touch display
Net volume 8.6 ft³ cu.ft. (242) litres
Energy Star certified

Operation

TFT touch display operation.
Clear text display in 44 languages.

Technical Features

Dynamic cold air distribution with Multi-Flow Air System.
Automatic defrosting with defrost water evaporation.
Cushioned door closing system.
Sabbath mode certified by Star-K.
When rest mode is active, the appliance can only be opened using a handle.
Open-door and malfunction warning system.
Home network integration for digital services (Home Connect) wireless via WiFi.
The use of the Home Connect functionality depends on the Home Connect services, which are not available in every country. For further information please check: home-connect.com.

Freezer compartment

No-frost technology with fast freezing at -22 °F.
Temperature adjustable from 3 °F to -11 °F.
4-star freezer compartment.
Freezing capacity 6.3 kg/24 h.
4 safety glass shelves, white glass, 3 of which are individually height adjustable.
2 fully extendable drawers with transparent front.
Brilliant LED light spots with warm white, glare-free light.
Flat door rail system with fully flexible positioning of door racks.
4 height-adjustable door racks.

Ice dispenser

Integrated automatic ice maker in the freezer compartment, with fixed water connection.
Particle filter for water inlet, integrated in ventilation grille area.

Product Features

Multi-Flow Air Tower

Yes

Number of compressors

1

Number of independent cooling systems

1

Eco Mode

Yes

SUPERFREEZE

No

Number of Door Bins - Freezer

4

Adjustable Door Bins - Freezer

No

Tilt-Out Door Bins - Freezer

No

Number of Shelves - Freezer

3

Adjustable Door Bins - Freezer

No

Shelf Material - Freezer

Safety glass

Door Hinge

Left reversible

Reversible Door Hinge

Yes

Consumption and connection features

UPC code

825225960911

Variant color

Not applicable

Panel ready

N/A

Installation Type

N/A

Silence level (dBA)

42

Watts (W)

350

Current (A)

10

Volts (V)

110-120

Frequency (Hz)

60

Total annual energy consumption (kWh)

404.0

Energy Star® qualified

No

Approval certificates

CSA

Power Cord Length

139 1/3"

Plug type

120V-3 prong

Appliance dimensions (h x w x d) inch

83 3/4 " x 17 3/4" x 24"

Required cutout size (HxWxD) (in)

84" x 18" x 24 3/4"

Appliance Width (in)

17 3/4"

Height (in)

83 3/4 "

Depth (in)

24"

Product packaging dimensions

(HxWxD) (in)

88.97 x 21.45 x 29.33

Total unit gross capacity (cu. ft.) - AHAM

8.6

Net weight (lbs)

278.000

Gross weight (lbs)

307.000

2020-11-04

Page 1

Saturation indicator shown in TFT touch display.

Ice maker can be switched off independently.

Ice cube production approx. 2.9 lb (1.4 kg)/24 h.

Removable ice storage container with approx. 6.6 lbs. (2.5 kg) capacity.

Consumption data

Energy consumption 404 kWh/year.

Noise level 42 dB (re 1 pW).

Planning notes

Flat hinge.

Door hinge left, reversible.

Door opening angle of 115°, fixable at 90°.

For installation with a door opening angle of 90° the ice storage container must be exchanged for the small ice storage container (RA 448220). This must be done prior to fixing the door. Max. door panel weight 55 lbs (25 kg).

Shut-off valve for water connection must be planned next to the appliance and always be accessible.

If the water pressure exceeds 116 psi, connect pressure relief valve between water tap and hose set.

Rating

Total rating 1.079 kWh/24 h.

Total Amps: 10 A.

Connecting cable 118" (3.0 m), detachable.

Cold water connection required.

Electrical location 6" above ground in lower left corner of unit.

Supply hose 51,1 INCH (1.3 m) with 1/4" male compression fitting (standard icemaker connector).

Water pressure 29 to 116 psi.

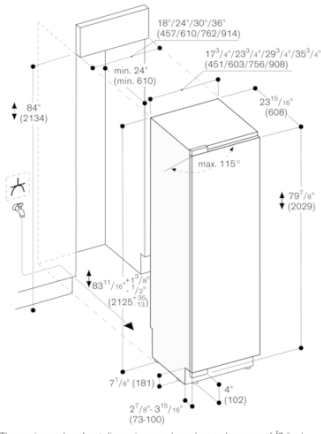

The maximum door front dimensions are based on a clearance of 3/8" (9.5mm).

