

# Freestanding Refrigerator Freezer, 32", 17.1 cu ft, Ice

Series 5 | Contemporary

Stainless Steel | Left hinge



This stylish left hinge refrigerator is designed to fit flush with your cabinetry and comes in timeless stainless steel.

- ActiveSmart™ Foodcare technology helps keep food fresher for longer
- Flat door that fits flush with cabinetry
- Brushed metal handles

## DIMENSIONS

|        |          |
|--------|----------|
| Height | 67 1/2"  |
| Width  | 31 3/32" |
| Depth  | 27 3/8"  |

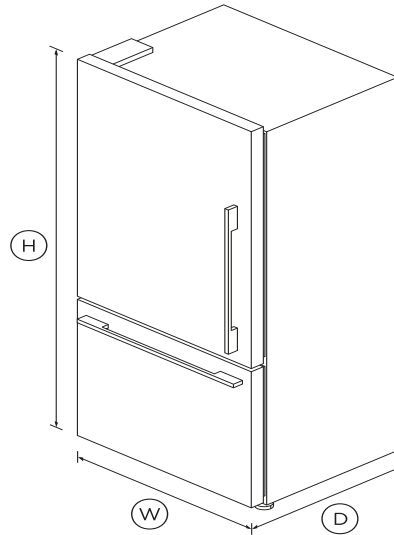

## FEATURES & BENEFITS

### ActiveSmart™ Foodcare

This refrigerator freezer adapts to daily use by cooling and defrosting only when needed. ActiveSmart™ Foodcare technology uses energy efficiently without compromising on food care.

### Flexible storage

Adjustable shelves and door storage give you plenty of room to stack and pack all your groceries. Storage bins give you full access inside when they're pulled open and can be easily

removed to clean.

### Humidity Control

Your fruit and veges need different environments to stay fresh. Humidity control in each storage bin allows you to maintain a microclimate that helps keep food fresher for longer.

### Design quality

Our fridges are designed and built using quality materials. We use real stainless steel on our fridges and solid glass for shelving.

### Internal ice maker

Fresh ice is always available for you in a dedicated freezer bin. Simply turn it off to free up freezer space or during busy times, you can boost ice production by up to 30%.

### Easy Cleaning

No more stubborn dirty marks with our EZKleen feature for stainless steel fridges. Anti-fingerprint coating means you simply wipe clean any marks. Spill-safe secure glass shelves easily capture any drips or leaks.

### Easy to use

The SmartTouch control panel has been designed to be intuitive for ease to use, and is conveniently placed near the front of the fridge.

## SPECIFICATIONS

### Accessories

|                                  |                   |
|----------------------------------|-------------------|
| Joiner kit                       | 819264            |
| Matching Replacement Water       | 847200            |
| Surround Kit (Joined left/right) | Part number 24476 |

### Capacity

|                      |           |
|----------------------|-----------|
| Total gross capacity | 17.1cu ft |
| Volume refrigerator  | 12.3cu ft |

**Consumption**

Energy usage **535kWh/year**

**Features**

|                          |   |
|--------------------------|---|
| Adjustable door shelves  | 4 |
| Adjustable glass shelves | 4 |
| Covered door shelves     | 2 |
| Door alarm               | • |
| Front levelling feet     | • |
| Fruit and vegetable bins | 2 |
| LED lighting             | • |
| Rear rollers             | • |
| SmartTouch control panel | • |
| Stackable bottle holders | 4 |

**Freezer Features**

|                     |   |
|---------------------|---|
| Automatic ice maker | • |
| Bottle chill        | • |
| Door alarm          | • |
| Fast freeze         | • |
| Ice Boost           | • |
| Ice bin and scoop   | • |
| Large plastic bins  | • |

**Performance**

|                                |   |
|--------------------------------|---|
| ActiveSmart™ technology        | • |
| Adaptive defrost               | • |
| Frost free freezer             | • |
| Humidity control system        | • |
| Inverter controlled compressor | • |

Sabbath mode •

**Power requirements**

|                  |                   |
|------------------|-------------------|
| Supply frequency | <b>60Hz</b>       |
| Supply voltage   | <b>110 - 120V</b> |

**Product dimensions**

|        |                 |
|--------|-----------------|
| Depth  | <b>27 3/8"</b>  |
| Height | <b>67 1/2"</b>  |
| Width  | <b>31 3/32"</b> |

**Warranty**

|                               |                           |
|-------------------------------|---------------------------|
| Parts and labor               | <b>2 years</b>            |
| Sealed system parts and labor | <b>additional 3 years</b> |

SKU **25948**

The product dimensions and specifications in this page apply to the specific product and model. Under our policy of continuous improvement, these dimensions and specifications may change at any time. You should therefore check with Fisher & Paykel's Customer Care Centre to ensure this page correctly describes the model currently available. © Fisher & Paykel Appliances Ltd 2020

**Other product downloads available at fisherpaykel.com**

- [↓](#) User Guide
- [↓](#) User Guide
- [↓](#) Energy Label
- [↓](#) Installation Guide
- [↓](#) Install Guide - Water Filter Replacement



**A PEACE OF MIND SALE**

**24 Hours 7 Days a Week Customer Support**

**T 1.888.936.7872 Wwww.fisherpaykel.com**