

PLANNING GUIDE
VENTILATION

VENTILATION QUICK REFERENCE CHART

Quick Reference Chart for Recommended Ventilation Based On Cooking System

MODEL SERIES	Minimum CFM Recommended		Updraft Ventilation Options ¹						Downdraft Ventilation Options ²			
	Wall	Island	Wall ³					Island ³			Cook 'N' Vent [®] Universal for Cooktops	
			HSB	HCSW HSW HTSW HGSW	HS HST	HDW	PH_Z PHE HNW	HGSI	HDI HTDI	PHI_Z HNI HTNI	CVS2	UCV
Gas or Electric Cooktops	300	400	■	■	■	■	■	■	■	■	■	■
30" Downdraft Ranges	600	600										
30" Free-standing or Slide-in Updraft Ranges	400	600	■	■	■	■	■	■	■			
Professional-style Ranges or cooktops for home applications	1000	1400					■			■		

¹ Updraft Width Guidelines:

The minimum hood width recommended for wall installation equals the cooktop or range width. Where space is not restricted, a wider hood can be used to increase your capture area. Island installations require a greater capture area, therefore the hoods used should overlap your appliance by a minimum of 3" - 6" on either side.

² Cook 'N' Vent 2 Width Guidelines:

The Cook 'N' Vent 2 system selected should match the width of your cooktop. Thermador offers 30", 36" or 45" widths. Due to the high performance requirements of Professional-style appliances for the home, an overhead hood is highly recommended.

³ Available Ceiling Height:

Before selecting your updraft hood, check your available installation space. This is determined by adding your floor-to-countertop height, plus the recommended spacing between your appliance and the bottom of the hood, plus the height of the hood. See product dimensions on pages 75-83.

NOTE:

Indoor Gas Grills:

The local codes may require a fire-rated construction for installation of open gas grill appliances. Please check with your local codes prior to installation.

VENTILATORS

Integral (Mounted on Hood) Ventilator Options

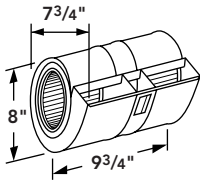
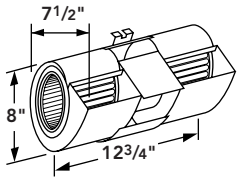
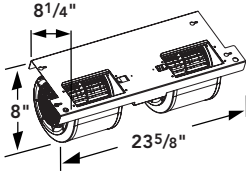
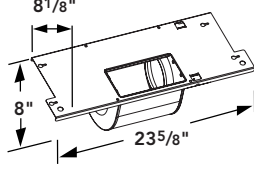
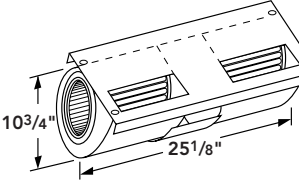
VCK300	VM410	VTN420B	VTN620B	VTN1000Q
				
Maximum CFM: 300	Maximum CFM: 390	Maximum CFM: 400	Maximum CFM: 600	Maximum CFM: 1000
Electrical Motor Rating 2.4 Amps @ 120 V AC, 60 Hz	Electrical Motor Rating 1.5 Amps @ 120 V AC, 60 Hz	Electrical Motor Rating 2.0 Amps @ 120 V AC, 60 Hz	Electrical Motor Rating 4.0 Amps @ 120 V AC, 60 Hz	Electrical Motor Rating 5 Amps @ 120 V AC, 60 Hz
Recommended Duct Size 3 1/4" x 10"	Recommended Duct Size 3 1/4" x 10"	Recommended Duct Size 8" round	Recommended Duct Size 8" round	Recommended Duct Size 10" round
Use in Control Housing VCK1	Use in Control Housing VCH8	Use in Control Housing N/A	Use in Control Housing N/A	Use in Control Housing N/A
Use in Hood Series N/A	Use in Hood Series N/A	Use in Hood Series Standard in HSB Series; option for HS or HST series	Use in Hood Series Option for HS or HST Series	Use in Hood Series Option for PH Series, wall models only

Remote (Roof or External Wall) Ventilator Options

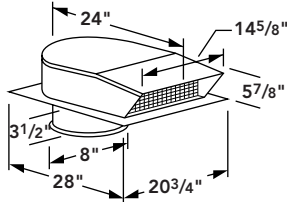
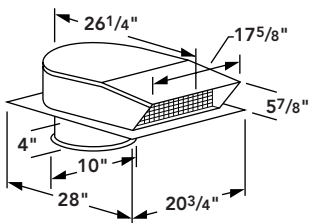
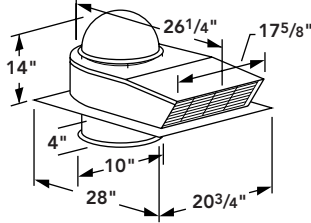
VTR600R	VTR1000Q	VTR1400Q
		
Maximum CFM: 600	Maximum CFM: 1000	Maximum CFM: 1400
Electrical Motor Rating 4.3 Amps @ 120 V AC, 60 Hz	Electrical Motor Rating 7.8 Amps @ 120 V AC, 60 Hz	Electrical Motor Rating 12.8 Amps @ 120 V AC, 60 Hz
Duct Size at Intake 8" round	Duct Size at Intake 10" round	Duct Size at Intake 10" round
Use in Control Housing VCK1, VCH8, VCH36	Use in Control Housing VCH36, VCH54*	Use in Control Housing VCH36, VCH54*
Use in Hood Series Option for HS or HST Series	Use in Hood Series Option for HS, HST, HNI, HNW, HTNI or PH Series	Use in Hood Series Option for HNI, HNW, HTNI, PH or PHI Series
	Note: Heavy-duty backdraft damper included**	Note: Heavy-duty backdraft damper included**

*When using the VCH54 control housing, you will also need a plenum (Model PLENUM) duct accessory. **No roof jack or wall cap required. Collar extends below mounting flange into roof or wall installation area.



Ventilators are UL and CUL approved.

CONTROL HOUSINGS FOR CUSTOM HOOD APPLICATIONS

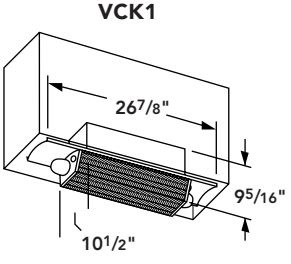
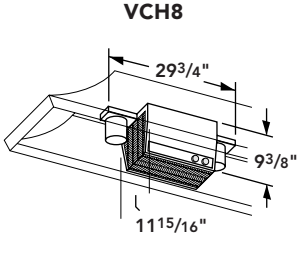
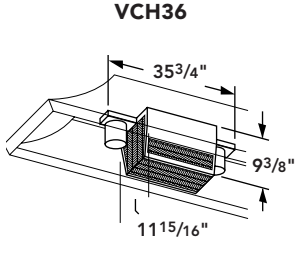
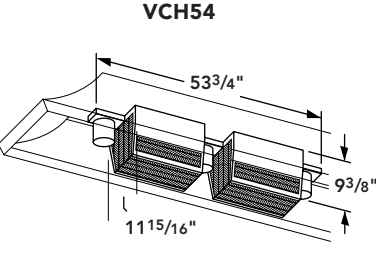
 <p>VCK1</p>	 <p>VCH8</p>	 <p>VCH36</p>	 <p>VCH54</p>
<p>Finish Black enamel with chrome reflector lights</p> <p>Application Shallow custom hood or kitchen cabinet</p> <p>Lighting Accepts two 60-watt bulbs</p> <p>Controls Solid-state infinite speed control and rotary light switch</p> <p>Notes:</p> <ol style="list-style-type: none"> 1. Only 4 1/8" exposed below cabinet cutout. 2. Lamps not included. 	<p>Finish Satin finish with removable single aluminum mesh filter screens</p> <p>Application For nonprofessional-style cooktops/ranges</p> <p>Lighting Accepts two 75-watt flood lamps</p> <p>Controls Solid-state infinite speed control</p> <p>Notes:</p> <ol style="list-style-type: none"> 1. Filter and lamp shields snap out for easy cleaning. 2. Lamps not included. 	<p>Finish Satin finish with removable single aluminum mesh filter screen</p> <p>Application Use with high heat applications in custom hoods of 36" width or greater</p> <p>Lighting Accepts two 75-watt flood lamps</p> <p>Controls Requires separate wall-mounted switches* for lights and ventilator</p> <p>Notes:</p> <ol style="list-style-type: none"> 1. Filter and lamp shields snap out for easy cleaning. 2. Lamps not included. 	<p>Finish Satin finish with removable dual aluminum mesh filter screens</p> <p>Application Use with high heat applications in custom hoods of 54" width or greater</p> <p>Lighting Accepts three 75-watt flood lamps</p> <p>Controls Requires separate wall-mounted switches* for lights and ventilator</p> <p>Notes:</p> <ol style="list-style-type: none"> 1. Filter and lamp shields snap out for easy cleaning. 2. Lamps not included. 3. Double filter housing for superior performance. 4. Requires PLENUM (sold separately from Thermador).

*Requires standard wall switch for light, plus Thermador CTRQ-3, three-speed ventilator control switch.

Recommended Thermador Ventilators**

<p>Internal Mounted VCK300</p> <p>Remote Mounted VTR600R</p>	<p>Internal Mounted VM410</p> <p>Remote Mounted VTR600R</p>	<p>Internal Mounted N/A</p> <p>Remote Mounted VTR600R, VTR1000Q, VTR1400Q</p>	<p>Internal Mounted N/A</p> <p>Remote Mounted VTR1000Q, VTR1400Q</p>
--	---	---	--

**Ventilator performance shown on page 75.



Control Housings are UL and CUL approved.

For immediate critical installation dimensions by fax, use your fax handset and call (775) 833-3600. Use code #8030 for a directory of Thermador® products.

UPDRAFT VENTILATION

Professional Series Hoods

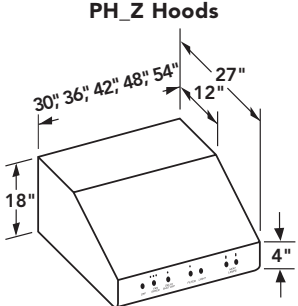
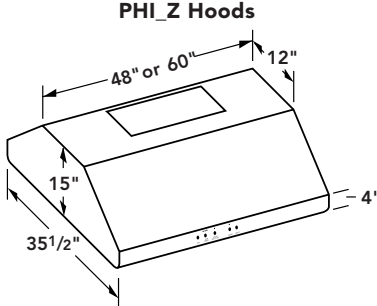
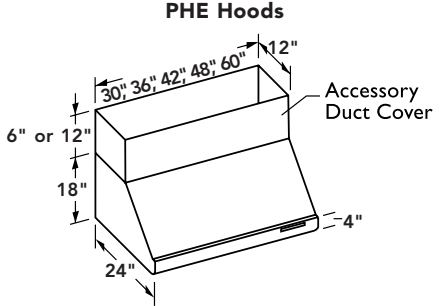
 <p>PH_Z Hoods</p>	 <p>PHI_Z Hoods</p>	 <p>PHE Hoods</p>
<p>Installation Type Wall</p> <p>Ventilator Options CFM 1000, Integral, Model VTN1000Q CFM 1000, Remote, Model VTR1000Q CFM 1400, Remote, Model VTR1400Q</p> <p>Finishes Stainless Steel</p> <p>Transition Model Required Included</p> <p>Duct Size at Discharge 10" round</p> <p>Discharge Direction Vertical or Horizontal</p> <p>Electrical Motor Rating VTN1000Q: 5.0 Amps @ 120 V AC, 60 Hz VTR1000Q: 7.8 Amps @ 120 V AC, 60 Hz VTR1400Q: 12.8 Amps @ 120 V AC, 60 Hz</p> <p>Hood Lighting Rating 430 watts & 3.6 Amps @ 120 V AC, 60 Hz</p> <p>Power Supply 20 Amps (min) @ 120 V AC, 60 Hz</p> <p>General Features Double wall construction Dual intensity halogen lighting (2) size G4, 12V, 20W halogen bulbs; 3 bulbs on 48" and 54" widths Two infrared "Keep-Hot" light sockets size PAR-38, 175W, 120V (included), PAR-40, 250W, 120V (optional) Dishwasher-safe commercial-style baffle filters 3-speed electronic controls U.L. approved for damp environments</p> <p>Accessory Options "Keep-Hot" Warming Shelf, supports max. weight of 30 lbs., Model KHS, in 30", 36", 42", 48" & 54" widths; wall cap (WC10) for VTN1000Q 12" High Duct Covers, Model DCT in 30", 36", 42" & 48" versions 6" High Duct Covers, Model DC in 30", 36", 42" & 48" versions Remote control for customized installations (cable-connected), Model PHREM (see p. 84)</p> <p>Approximate Shipping Weight 30" – 69 lbs. 48" – 98 lbs. 36" – 78 lbs. 54" – 108 lbs. 42" – 88 lbs.</p>	<p>Installation Type Island</p> <p>Ventilator Options CFM 1400, Remote, Model VTR1400Q</p> <p>Finishes Stainless Steel</p> <p>Transition Model Required Included</p> <p>Duct Size at Discharge 10" round</p> <p>Discharge Direction Vertical</p> <p>Electrical Motor Rating VTR1400Q: 12.8 Amps @ 120 V AC, 60 Hz</p> <p>Hood Lighting Rating 80 watts and .8 Amps @ 120 V AC, 60 Hz</p> <p>Power Supply 20 Amps (min) @ 120 V AC, 60 Hz</p> <p>General Features Double wall construction Dual intensity halogen lighting (4) size G4, 12V, 20W halogen bulbs (included) Dishwasher-safe commercial-style baffle filters 3-speed electronic controls U.L. approved for damp environments</p> <p>Accessory Options Remote control for customized installations (cable-connected), Model PHIREM (see p. 84)</p> <p>Approximate Shipping Weight 48" – 98 lbs. 60" – 148 lbs.</p>	<p>Installation Type Wall</p> <p>Ventilator Options CFM 1000, Integral, Model VTN1000Q CFM 1000, Remote, Model VTR1000Q CFM 1400, Remote, Model VTR1400Q</p> <p>Finishes Stainless Steel</p> <p>Transition Model Required Included</p> <p>Duct Size at Discharge 10" round</p> <p>Discharge Direction Vertical or Horizontal</p> <p>Electrical Motor Rating VTN1000Q: 5.0 Amps @ 120 V AC, 60 Hz VTR1000Q: 7.8 Amps @ 120 V AC, 60 Hz VTR1400Q: 12.8 Amps @ 120 V AC, 60 Hz</p> <p>Hood Lighting Rating 80 watts and .8 Amps @ 120 V AC, 60 Hz</p> <p>Power Supply 20 Amps @ 120 V AC, 60 Hz</p> <p>General Features Double wall construction Dual intensity halogen lighting (4) size G4, 12V, 20W halogen bulbs (included) Dishwasher-safe aluminum mesh filters 3-speed electronic controls U.L. approved for damp environments Utensil rail standard</p> <p>Accessory Options 12" High Duct Covers, Model DCT in 30", 36", 42", 48" & 60" versions 6" High Duct Covers, Model DC in 30", 36", 42", 48" & 60" versions</p> <p>Approximate Shipping Weight 30" – 57 lbs. 36" – 64 lbs. 42" – 72 lbs. 48" – 79 lbs. 60" – 95 lbs.</p>



Control Housings are UL and CUL approved.

UPDRAFT VENTILATION

Traditional Series Hoods

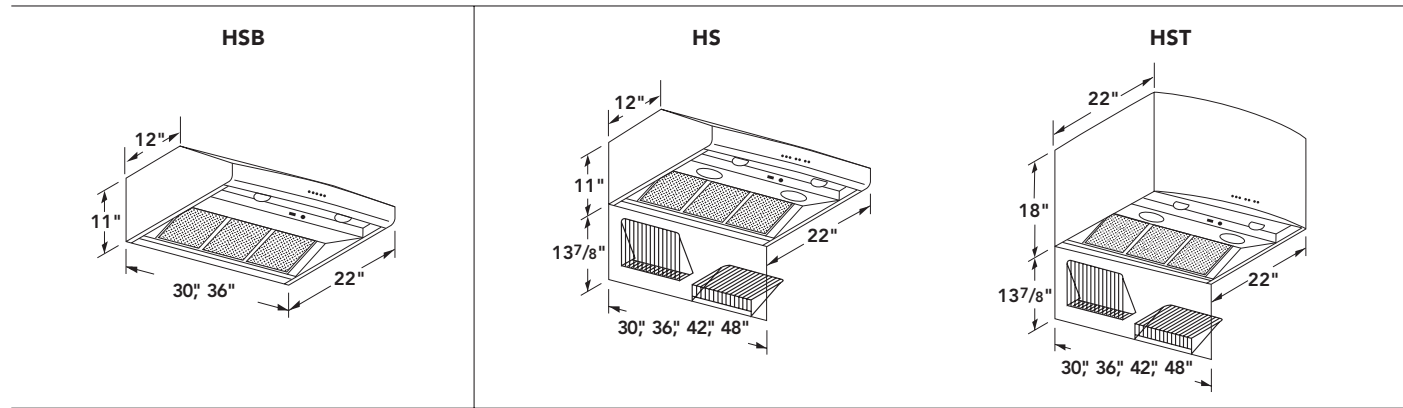

HSB Hoods

Installation Type

Wall

Ventilator Options

CFM 400, Integral, supplied with hood

Finishes

White or Black Porcelain Enamel,
Stainless Steel

Transition Model Required

Included with hood, which includes
backdraft damper

Duct Size at Discharge

8" round

Discharge Direction

Vertical or Horizontal

Electrical Motor Rating

1.5 Amps @ 120 V AC, 60 Hz

Hood Lighting Rating

100 watts and .8 Amps @ 120 V AC, 60 Hz

Power Supply

15 Amps (min) @ 120 V AC, 60 Hz

General Features

Double wall construction

Push button controls

Incandescent lighting

Dishwasher-safe aluminum mesh filters

3-Speed blower controls

Includes VTN420B Ventilator

Accessory Options

Roof jack or wall cap sold separately at
most home improvement stores

Accessory duct cover DC, DCT sold
separately

Recirculation kits available in 30" and 36"
widths (see p. 84)

Order separately by width and color
(RECIRC__B_)

Approximate Shipping Weight

30" – 73 lbs. 36" – 78 lbs.

HS Hoods & HST Hoods (shown with optional KHS)

Installation Type

Wall

Ventilator Options

CFM 400, Integral,
Model VTN420B

CFM 600, Integral,
Model VTN620B

CFM 600, Remote,
Model VTR600R

CFM 1000, Remote,
Model VTR100Q

Finishes

Stainless Steel

Transition Model Required

Included with hood, which includes
backdraft damper

Duct Size at Discharge

8" round

Discharge Direction

Vertical or Horizontal

Electrical Motor Rating

VTN420B: 2.0 Amps @ 120 V AC, 60 Hz

VTN620B: 4.0 Amps @ 120 V AC, 60 Hz

VTR600R: 4.3 Amps @ 120 V AC, 60 Hz

VTR1000Q: 7.8 Amps @ 120 V AC, 60 Hz

Hood Lighting Rating

600 watts and 5.0 Amps @ 120 V AC,
60 Hz

Power Supply

15 Amps (min) @ 120 V AC, 60 Hz

General Features

Double wall construction

Electronic controls

Dual-intensity halogen lighting, (2) size
R20, 50-watt maximum

Two infrared "Keep-Hot" light sockets,
size R40, 250-watt maximum

Dual-stage, "soft-start" lighting (HST)

Dishwasher-safe aluminum mesh filters

3-speed blower control

Recirculation kits available in 30," 36," 42,"
48" widths (HS or HSB Models only)
(see p. 84)

Order separately by width and color
(RECIRC__B_)

Accessory Options

"Keep-Hot" Warming Shelf, supports
maximum weight of 30 lbs., Model KHS,
in 30," 36," 42," 48" & 54" widths

Roof Jack or Wall Cap sold separately at
most home improvement stores when
using VTN420B or VTN620B

Telescoping duct cover HSTD, sold
separately (HST)

Accessory duct cover DC, DCT sold
separately (HS)

Approximate Shipping Weight

HS Models:

30" – 55 lbs.

36" – 69 lbs.

42" – 73 lbs.

48" – 83 lbs.

HST Models:

30" – 87 lbs.

36" – 101 lbs.

42" – 110 lbs.

48" – 120 lbs.



Hoods are UL and CUL approved.

For immediate critical installation dimensions by fax, use your fax handset and call (775) 833-3600. Use code #8030 for a directory of Thermador® products.

UPDRAFT VENTILATION

Chimney-Style Hoods

HDW/HNW Chimney-Style Hoods

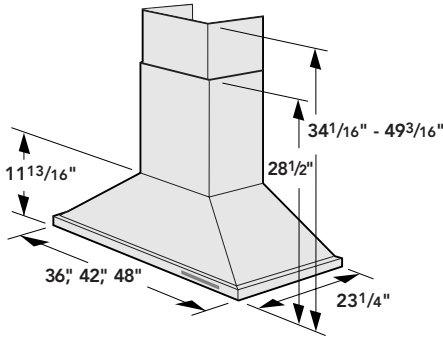

HDW/HNW Chimney Covers

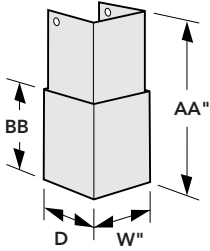

Installation Type

Wall

Ventilator Options

HDW-CFM 770, Integral, supplied with hood

HNW-CFM 1000 or 1400, Remote, purchase separately

Finishes

Stainless Steel

Transition Model Required

Included*

Duct Size at Discharge

8" round

Discharge Direction

Vertical

Electrical Motor/Lighting Rating

HDW36: 4.5 Amps @ 120 V AC, 60 Hz

HDW42/48: 4.9 Amps @ 120 V AC, 60 Hz

Power Supply

15 Amps (min.) @ 120 V AC, 60 Hz

General Features

Adjustable chimney height at installation

Welded, polished seams

12-volt halogen lighting
(2 lights in 36", 4 lights in 42" and 48")

Dishwasher-safe aluminum mesh filters

Electronic touch control panel

40-hour clean filter reminder light

10-minute intensive ventilation program

10-minute delayed shutoff

Hood comes complete with filters, lights, backdraft damper and transition

Accessory Options

Substitute metal transition (HDTR8-HDW)

(Metal Transition included – HNW)

Approximate Shipping Weight

36" – 60 lbs. 42" – 64 lbs. 48" – 73 lbs.

HDW/HNW

Width x Depth: 12¹⁵/₁₆" x 9¹³/₁₆"

AA (Cover adj. height): 22³/₁₆" – 38⁷/₁₆"

BB (Cover min. height): 17¹¹/₁₆"

*An additional transition to 10" round is required for remote blowers and is sold separately at most home improvement stores.



UPDRAFT VENTILATION

Chimney-Style Hoods

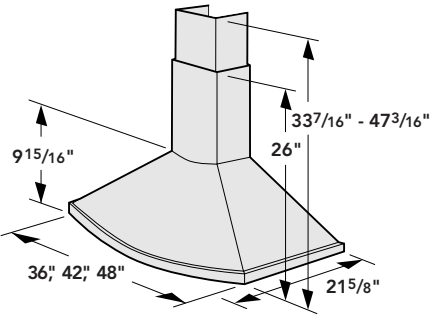
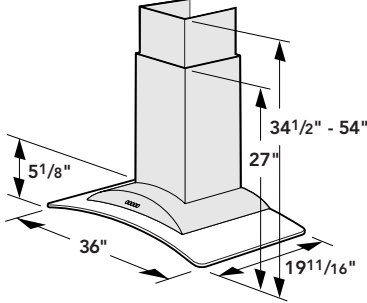
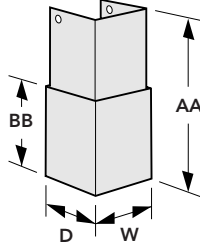
<p style="text-align: center;">HCSW Chimney-Style Hoods</p> 	<p style="text-align: center;">HGSW Chimney-Style Hoods</p> 	<p style="text-align: center;">HCSW/HGSW Chimney Covers</p> 
<p>Installation Type Wall</p> <p>Ventilator Options CFM 400, Integral, supplied with hood</p> <p>Finishes Stainless Steel</p> <p>Transition Model Required Included</p> <p>Duct Size at Discharge 6" round</p> <p>Discharge Direction Vertical or Horizontal</p> <p>Electrical Motor/Lighting Rating 2.5 Amps @ 120 V AC, 60 Hz</p> <p>Power Supply 15 Amps (min.) @ 120 V AC, 60 Hz</p> <p>General Features Adjustable chimney height at installation Welded, polished seams Two 12-volt halogen lights Dishwasher-safe aluminum mesh filters Electronic touch controls 10-minute intensive ventilation program 10-minute delayed shutoff Hood comes complete with filters, lights, backdraft damper and transition</p> <p>Accessory Options Substitute metal transition (HSTR6)</p> <p>Approximate Shipping Weight 30" – 37 lbs. 36" – 57 lbs. 42" – 62 lbs. 48" – 68 lbs.</p>	<p>Installation Type Wall</p> <p>Note: See HGSI for Island version</p> <p>Ventilator Options CFM 400, Integral, supplied with hood</p> <p>Finishes Stainless Steel with Glass Canopy</p> <p>Transition Model Required Included</p> <p>Duct Size at Discharge 6" round</p> <p>Discharge Direction Vertical or Horizontal</p> <p>Electrical Motor/Lighting Rating 2.5 Amps @ 120 V AC, 60 Hz</p> <p>Power Supply 15 Amps (min.) @ 120 V AC, 60 Hz</p> <p>General Features Adjustable chimney height at installation Welded, polished seams Two 12-volt halogen lights Dishwasher-safe aluminum mesh filters Push button controls Hood comes complete with filters, lights, backdraft damper and transition</p> <p>Accessory Options Substitute metal transition (HGTR6)</p> <p>Approximate Shipping Weight 36" – 88 lbs.</p>	<p>HCSW Width x Depth: 8³/₁₆" x 6⁷/₈" AA (Cover adj. height): 23⁷/₁₆" x 37⁵/₈" BB (Cover min. height): 16"</p> <p>HGSW Width x Depth: 11³/₄" x 11³/₄" AA (Cover adj. height): 29⁵/₁₆" – 50¹/₄" BB (Cover min. height): 21¹³/₁₆"</p>



Hoods and Chimney Covers are UL and CUL approved.

For immediate critical installation dimensions by fax, use your fax handset and call (775) 833-3600. Use code #8030 for a directory of Thermador® products.

UPDRAFT VENTILATION

Chimney-Style Hoods

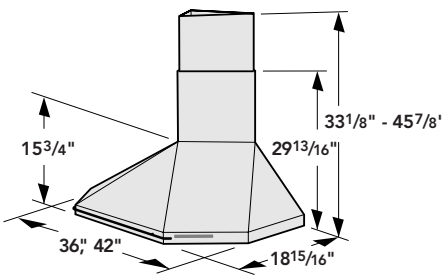
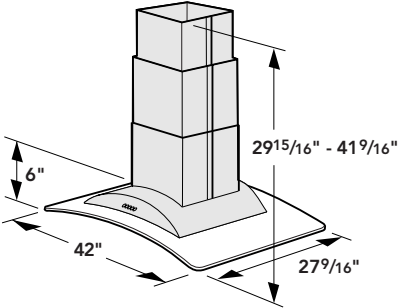
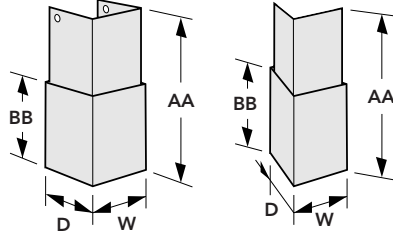
<p style="text-align: center;">HTSW Chimney-Style Hoods</p> 	<p style="text-align: center;">HGSI Chimney-Style Hoods</p> 	<p style="text-align: center;">HTSW/HGSI Chimney Covers</p> 
<p>Installation Type Wall Note: See HTDI for Island version</p> <p>Ventilator Options CFM 400, Integral, supplied with hood</p> <p>Finishes Stainless Steel</p> <p>Transition Model Required Included</p> <p>Duct Size at Discharge 6" round</p> <p>Discharge Direction Vertical or Horizontal</p> <p>Electrical Motor/Lighting Rating 2.5 Amps @ 120 V AC, 60 Hz</p> <p>Power Supply 15 Amps (min.) @ 120 V AC, 60 Hz</p> <p>General Features Adjustable chimney height at installation Welded, polished seams Two 12-volt halogen lights Dishwasher-safe aluminum mesh filters Electronic touch controls 40-hour clean filter reminder light 10-minute intensive ventilation program 10-minute delayed shutoff Polished chrome rail Hood comes complete with filters, lights, backdraft damper and transition</p> <p>Accessory Options Substitute metal transition (HGTR6)</p> <p>Approximate Shipping Weight 36" – 57 lbs. 42" – 68 lbs.</p>	<p>Installation Type Island Note: See HGSW for Wall version</p> <p>Ventilator Options CFM 400, Integral, supplied with hood</p> <p>Finishes Stainless Steel with Glass Canopy</p> <p>Transition Model Required Included</p> <p>Duct Size at Discharge 6" round</p> <p>Discharge Direction Vertical</p> <p>Electrical Motor/Lighting Rating 3 Amps @ 120 V AC, 60 Hz</p> <p>Power Supply 15 Amps (min.) @ 120 V AC, 60 Hz</p> <p>General Features Adjustable chimney height at installation Welded, polished seams Four 12-volt halogen lights Dishwasher-safe aluminum mesh filters Push-button controls Hood comes complete with filters, lights, backdraft damper and transition</p> <p>Accessory Options Substitute metal transition (HGTR6)</p> <p>Approximate Shipping Weight 42" – 132 lbs.</p>	<p>HTSW Width x Depth: 15⁷/₁₆" x 10⁵/₁₆" AA (Cover adj. height): 17⁵/₁₆" x 30³/₁₆" BB (Cover min. height): 14"</p> <p>HGSI Width x Depth: 11³/₄" x 11³/₄" AA (Cover adj. height): 25¹/₄" – 32¹⁵/₁₆" BB (Cover min. height): N/A</p>



Hoods and Chimney Covers are UL and CUL approved.

UPDRAFT VENTILATION

Chimney-Style Hoods

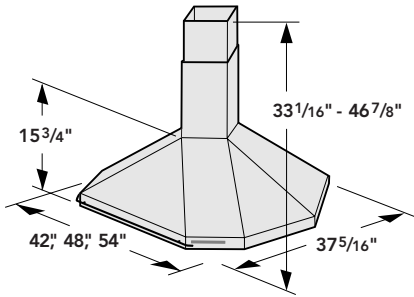
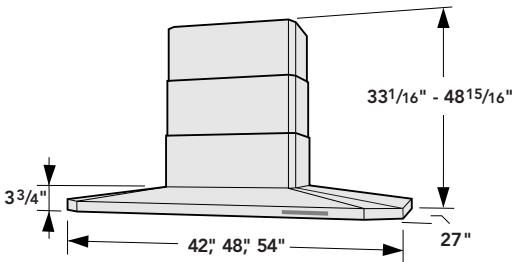
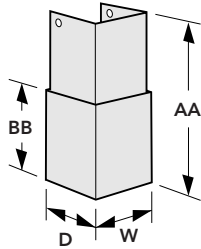
<p style="text-align: center;">HTNI Chimney-Style Hoods</p> 	<p style="text-align: center;">HDI/HNI Chimney-Style Hoods</p> 	<p style="text-align: center;">HDI/HNI Chimney Covers</p> 
<p>Installation Type Island Note: See HTSW for Wall version</p> <p>Ventilator Options HTNI-CFM 1000, or 1400 Remote, purchase separately</p> <p>Finishes Stainless Steel</p> <p>Transition Model Required Included*</p> <p>Duct Size at Discharge 8" round</p> <p>Discharge Direction Vertical</p> <p>Electrical Motor/Lighting Rating 4.5 Amps @ 120 V AC, 60 Hz</p> <p>Power Supply 15 Amps (min.) @ 120 V AC, 60 Hz</p> <p>General Features Adjustable chimney height at installation Welded, polished seams Four 12-volt halogen lights Dishwasher-safe aluminum mesh filters Electronic touch control panel 40-hour clean filter reminder light 10-minute intensive ventilation program 10-minute delayed shutoff Polished chrome rail Hood comes complete with filters, lights, backdraft damper and transition</p> <p>Accessory Options Substitute metal transition (HDTR8-HTDI) (Metal transition included – HTNI)</p> <p>Approximate Shipping Weight 42" – 99 lbs. 48" – 115 lbs. 54" – 128 lbs.</p>	<p>Installation Type Island</p> <p>Ventilator Options HDI-CFM 770, Integral, supplied with hood HNI-CFM 1000 or 1400, Remote, purchase separately</p> <p>Finishes Stainless Steel</p> <p>Transition Model Required Included*</p> <p>Duct Size at Discharge 8" round</p> <p>Discharge Direction Vertical</p> <p>Electrical Motor/Lighting Rating 4.9 Amps @ 120 V AC, 60 Hz</p> <p>Power Supply 15 Amps (min.) @ 120 V AC, 60 Hz</p> <p>General Features Adjustable chimney height at installation Welded, polished seams Compact fluorescent lights Dishwasher-safe aluminum mesh filters Electronic touch control panel 40-hour clean filter reminder light 10-minute intensive ventilation program 10-minute delayed shutoff Hood comes complete with filters, lights, backdraft damper and transition</p> <p>Accessory Options Substitute metal transition (HDTR8-HDI) (Metal transition included – HNI)</p> <p>Approximate Shipping Weight 42" – 86 lbs. 48" – 97 lbs. 54" – 104 lbs.</p>	<p>HTDI/HTNI Width x Depth: 11" x 11" AA (Cover adj. height): 17¹⁵/₁₆" – 31¹/₈" BB (Cover min. height): N/A</p> <p>HDI/HNI Width x Depth: 19¹¹/₁₆" x 15¹³/₁₆" AA (Cover adj. height): 29⁵/₁₆" x 45³/₁₆" BB (Cover min. height): N/A</p>

*An additional transition to 10" round is required for remote blowers and is sold separately at most home improvement stores.



Hoods and Chimney Covers are UL and CUL approved.

For immediate critical installation dimensions by fax, use your fax handset and call (775) 833-3600. Use code #8030 for a directory of Thermador® products.

DOWNDRAFT VENTILATION

Cook 'N' Vent® System

Cook 'N' Vent (CVS2) Intake

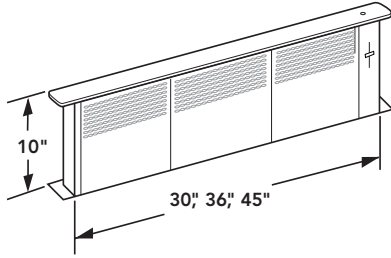

Universal Cook 'N' Vent (UCV) Intake

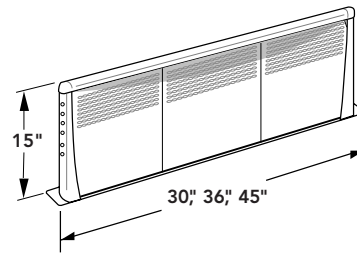

Installation Type

Wall* or Island

Dimensions

Available Widths: 30," 36" or 45"

Ventilator Options

- CFM 600, Integral, Model VTN600CVS2 (CVS2 models)
- CFM 600, Integral, Model VTN600CVA (UCV models)
- CFM 600, Remote, Model VTR600R (CVS2 or UCV models)
- CFM 1000, Remote, Model VTR1000Q (CVS2 or UCV models)

Finishes (Top Cap only)

White or Black Porcelain Enamel, Stainless Steel

Transition Model Required/Duct Size at Discharge

Must order one of the following for all remote ventilator installations:

- CVS2: CV2T6 – Transition to 6" round duct
- UCV: CVT7 – Transition to 7" round duct
- CVT314 – Transition to 3¹/₄" x 14" duct

Discharge Direction

Straight Down, Left or Right

Electrical Motor Rating

10.2 Amps @ 120 V AC, 60 Hz

Power Supply

15 amps (min.) @ 120 V AC, 60 Hz

General Features

Universal Cook 'N' Vent intakes are designed for installation with all nonprofessional-style cooktops

Top cap design color-matched to black, white and stainless steel cooktops

Single-touch up/down control for intake

Easy-to-remove, dishwasher-safe aluminum mesh filters

CVS Features:

Recessed infinite speed control is visible only when intake is in raised position

Raises 10" when in use

UCV Features:

Raises 15" when in use

Electronic controls

Delayed shut-off

Clean filter reminder

Full-face filters

Accessory Options

Ventilators and duct transitions stated

Approximate Shipping Weight

30" – 55 lbs. 36" – 61 lbs. 45" – 70 lbs.

* Requires minimum of 24" deep cabinet

Cook 'N' Vent Ventilator Options

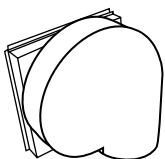
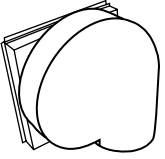
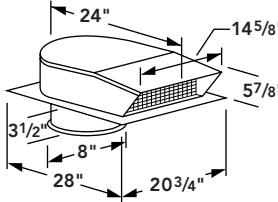
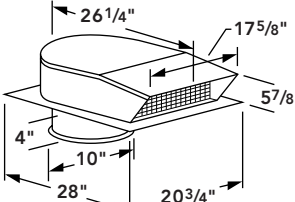
<p>VTN600CV2C</p> 	<p>VTN600CVA</p> 	<p>VTR600R†</p> 	<p>VTR1000Q†</p> 
<p>Maximum CFM: 600</p> <p>Electrical Motor Rating 3.4 Amps @ 120 V AC, 60 Hz</p> <p>Duct Size at Discharge 6" round</p> <p>Transition Models N/A</p> <p>Usable with Updraft Hood No</p> <p>Note: Backdraft damper (RJ310) or wall cap (WC310) required.</p>	<p>Maximum CFM: 600</p> <p>Electrical Motor Rating 3.4 Amps @ 120 V AC, 60 Hz</p> <p>Duct Size at Discharge 6" round</p> <p>Transition Models N/A</p> <p>Usable with Updraft Hood No</p>	<p>Maximum CFM: 600</p> <p>Electrical Motor Rating 4.3 Amps @ 120 V AC, 60 Hz</p> <p>Duct Size at Ventilator 8" round</p> <p>Transition Models** CVS: CVD310 (3¹/₄" x 10") CVD314 (3¹/₄" x 14") UCV: CVT7 (7" round) CVT314 (3¹/₄" x 14")</p> <p>Usable with Updraft Hood Yes</p>	<p>Maximum CFM: 1000</p> <p>Electrical Motor Rating 7.8 Amps @ 120 V AC, 60 Hz</p> <p>Duct Size at Ventilator 10" round</p> <p>Transition Models** CVS: CVD310 (3¹/₄" x 10") CVD314 (3¹/₄" x 14") UCV: CVT7 (7" round) CVT314 (3¹/₄" x 14")</p> <p>Usable with Updraft Hood Yes</p>

**Requires one of the transitions stated for proper installation and a secondary transition to duct size.

†No roof jack or wall cap required. Collar on Ventilator extends below mounting flange into roof or wall installation area.

VENTILATION

Accessories

Remote Control Panel for Customized Installations

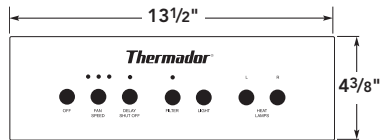

Telescoping Duct Cover

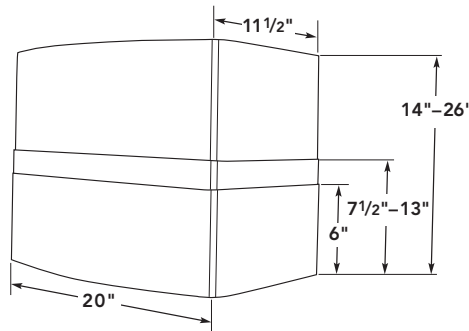

Recirculation Kit

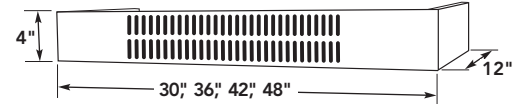

For Customized Installations

Available for Professional Series Models:

PH_Z (Wall Installation):
Model PHREM

PHI_Z (Island Installation):
Model PHIREM

Connection to Ventilator and Hood Controls:

Cable-connected

Approximate Shipping Weight

PHREM – 3 lbs.
PHIREM – 3 lbs.

Cutout Size

3 3/8" x 11 1/4"

For Use with HST Series Hoods

Fits all HST Sizes
(30", 36", 42", 48")

Approximate Shipping Weight

30" – 17 lbs.
36" – 17 lbs.
42" – 17 lbs.
48" – 17 lbs.

For Use with HS and HSB Series Hoods

Finishes

White

30" – RECIRC30BW

36" – RECIRC36BW

Black

30" – RECIRC30BB

36" – RECIRC36BB

Stainless Steel

30" – RECIRC30BS

36" – RECIRC36BS

42" – RECIRC42BS

48" – RECIRC48BS

Approximate Shipping Weight

30" – 13 lbs.

36" – 16 lbs.

42" – 18 lbs.

48" – 21 lbs.

Chimney Cover

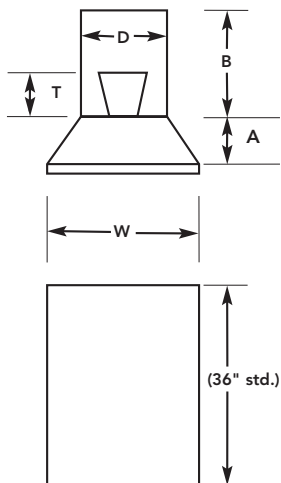

For Use with Professional Series Island Hoods (PHI_Z)

PHICHIM Height (B)

PHICHIM15 (Min to Max): 9 1/4" – 14 1/4"

PHICHIM27 (Min to Max): 15" – 21"

PHICHIM51 (Min to Max): 27" – 51"

Canopy Height (A)

15"

Transition Height (T)

10"

Hood Width (W)

PHI48ZS: 48"

PHI60ZS: 60"

Chimney Depth (D)

10"

Duct Size

10" Diameter

Approximate Shipping Weight

83 lbs.



All refrigerators are UL and CUL approved.

For immediate critical installation dimensions by fax, use your fax handset and call (775) 833-3600. Use code #8030 for a directory of Thermador® products.