

# BERTAZZONI PROFESSIONAL SERIES

## 30" 4-INDUCTION ZONES, SELF CLEAN OVEN PRO30 4INS X



Bertazzoni Professional Series ranges bring the authentic experience of Italian cooking to the heart of your home. They are available in stainless steel and six beautiful colors inspired by the wonderful produce of Emilia, the heartland of Bertazzoni. The Professional 30-inch induction range has a self-clean oven with European convection, providing balanced air flow and even heat distribution for single and multi-level roasting and baking with no flavor crossover. The oven includes telescopic glide shelves and quadruple-glass windows to minimize heat loss. The beautiful worktop has four different induction zones. Each induction zone has variable low-to-high power, and a pan detection system. Residual heat indicators warn if a zone is still hot, even when switched off guaranteeing maximum safety. Complete your Bertazzoni range with any of the available ventilation and backsplash solutions, as well as low profile trim, toekick and other beautiful accessories.

### INDUCTION MAINTOP



Induction cooktop surface accommodate full-size cookware and allow a wide range of different dishes to be prepared very quickly with minimal energy output.

### TELESCOPIC GLIDE SHELVES



The telescopic oven rack provides more convenient oven access and easier handling of hot and heavy dishes.



TO COOK BEAUTIFULLY

# BERTAZZONI PROFESSIONAL SERIES

## 30" 4-INDUCTION ZONES, SELF CLEAN OVEN PRO30 4INS X

### COLORS OF ITALY

Color is an essential expression of Italian exuberance and artistic elegance. Bertazzoni celebrates these special qualities with seven color choices inspired by the wonderful produce of Emilia-Romagna, heartland of Italian food since Roman times.



STAINLESS (X)  
PRO30 4INS X



BLACK (NE)  
PRO30 4INS NE



WHITE (BI)  
PRO30 4INS BI



YELLOW (GI)  
PRO30 4INS GI



ORANGE (AR)  
PRO30 4INS AR



RED (RO)  
PRO30 4INS RO



BURGUNDY (VI)  
PRO30 4INS VI

### FEATURES

<b>Induction Zones</b>	4
<b>Maintop</b>	induction
<b>Maintop Controls</b>	knobs
<b>Residual Heat Indicator</b>	yes
<b>Knobs</b>	metal finish
<b>Backguard</b>	standard 4 inches
<b>Front Left</b>	7" 3/32-1850 W (Booster 3000 W)
<b>Back Left</b>	7" 3/32-1850 W (Booster 3000 W)
<b>Front Right</b>	5" 45/64-1400 W (Booster 2200 W)
<b>Back Right</b>	8" 17/64-2300 W (Booster 3700 W)
<b>Main oven</b>	electric convection self-clean with electric broiler
<b>Main oven functions</b>	convection, bake, convection bake, turbo convection, convection broil, defrost/dehydrate, proofing, warming, broil, self clean
<b>Main oven volume</b>	3.4 ft <sup>3</sup>
<b>Inner oven door</b>	quadruple glass
<b>Oven equipment</b>	1 telescopic glide shelf, 1 baking tray, 2 heavy gauge wire shelves, 1 grill trivet for tray
<b>Legs</b>	height adjustable stainless steel wrapped legs

### TECHNICAL SPECIFICATIONS

<b>Voltage, frequency</b>	120/208 V - 120/240 V, 60Hz
<b>Max Amp Usage, power rating</b>	53 A - 11800 W, 56 A - 12900 W
<b>Certification</b>	cETLus
<b>Warranty</b>	2 years parts and labor

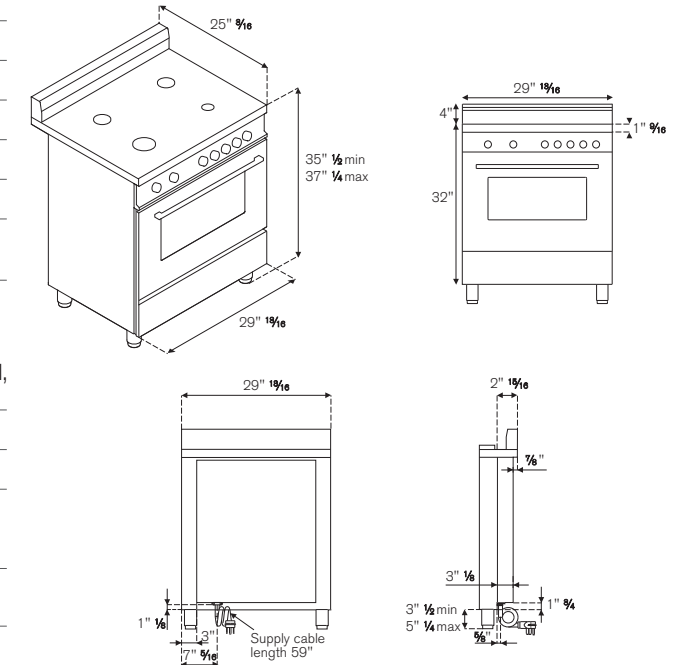

### ACCESSORIES

Toe kick panel (TKS 30 X), flat island trim (IRF 30 X), side trim (ST 36 X)

### MATCHING VENTILATION SOLUTIONS

Bertazzoni offers a variety of matching ventilation solutions for this range. Please check our website under the ventilation tab for a complete overview of all choices

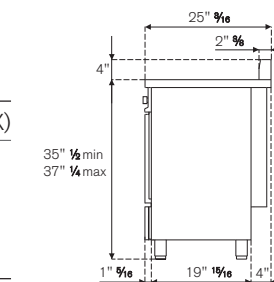

### INSTALLATION INSTRUCTIONS

Bertazzoni recommends to operate the appliance after it has been installed in a cabinet. The kitchen cabinets shall be made of materials capable of withstanding temperatures at least 117°F (65°C) above room temperature in order to avoid possible damage to the cabinets during oven usage. For further installation instructions refer to the installation manual.

**Disclaimer:** while every effort has been made to insure the accuracy of the information contained in this brochure, Fratelli Bertazzoni reserves the right to change any part of the information at any time without notice.

Fratelli Bertazzoni, Bertazzoni and the winged wheel brand icon are registered trademarks of Bertazzoni Spa.

bertazzoni.com