BERTAZZONI PROFESSIONAL SERIES

24" 4 BURNER GAS OVEN RANGE

PRO24 4 GAS X



Bertazzoni Professional Series ranges bring the authentic experience of Italian cooking to the heart of your home. The Professional 24" gas range has an oven with balanced air-flow convection fan to provide even heat distribution for single and multi-level roasting and baking with no flavor crossover. The oven includes soft-motion door hinges for easy one-hand operation and triple-glass windows to minimize heat loss. The beautiful worktop is precision-molded off of one sheet of stainless steel. It is configured with four versatile gas burners, including Bertazzoni's signature dual-ring power burner with independently controlled flames for high power to delicate simmer. The worktop is designed for high-efficiency in heat delivery without energy waste. Each burner is equipped with the thermocouple gas shut-off safety system for maximum safety. Complete your Bertazzoni range with any of the available ventilation and backsplash solutions, as well as low profile trim, toekick and other beautiful accessories.

SOFT MOTION DOOR



The soft-motion oven door is specially designed and carefully balanced for easy opening and smooth closing with one hand.



TO COOK BEAUTIFULLY

BERTAZZONI PROFESSIONAL SERIES

24" 4 BURNER GAS OVEN RANGE - PRO24 4 GAS X

FEATURES

Gas burners	4
Burner type	aluminum
Maintop	one piece stainless steel sheet
Burner controls	knobs
Knobs	metal finish
Grates	cast iron
Backguard	standard 4 inches
Gas safety device	thermocouple technology
One hand ignition	standard
Standard accessories	wok ring & simmer plate
Dual Power burner	750 - 18,000 Btu/h
Rapid burner	11,000 Btu/h
Semi-rapid burner	6500 Btu/h
Auxiliary burner	3400 Btu/h
Simmer rate	750 Btu/h
Main oven	gas convection with gas infrared broiler
Main oven functions	traditional bake, gas convection, broil, defrost/dehydrate
Main oven volume	2.4 ft ³
Inner oven door	full - width triple glass
Oven equipment	1 baking tray, 2 heavy gauge wire shelves, 1 grill trivet for tray
Legs	height-adjustable stainless steel legs

TECHNICAL SPECIFICATIONS

Voltage, frequency	120 V, 60Hz
Max Amp Usage, power rating	1.5 A - 150 W
Certification	CSA
Warranty	2 years parts and labor

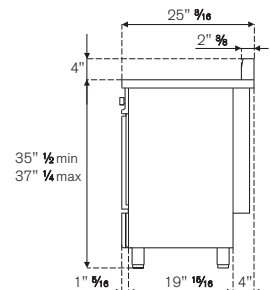
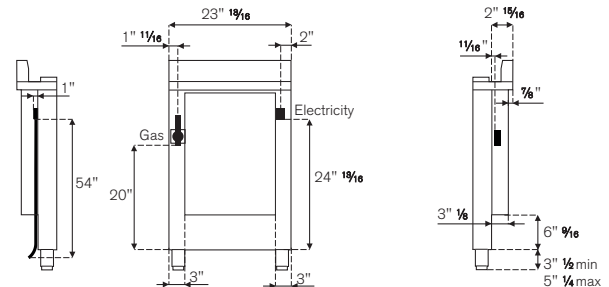
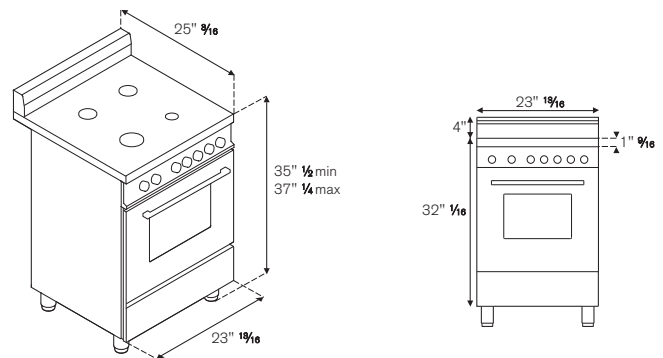

INSTALLATION INSTRUCTIONS

Bertazzoni recommends to operate the appliance after it has been installed in a cabinet. The kitchen cabinets shall be made of materials capable of withstanding temperatures at least 117°F (65°C) above room temperature in order to avoid possible damage to the cabinets during oven usage. For further installation instructions refer to the installation manual.

ACCESSORIES

Toe kick panel (TKS 24 X), flat island trim (IRF 24 X), side trim (ST 36 X)

Available LPG version PRO24 4 GAS X LP

MATCHING VENTILATION SOLUTIONS

Bertazzoni offers a variety of matching ventilation solutions for this range. Please check our website under the ventilation tab for a complete overview of all choices

Disclaimer: while every effort has been made to insure the accuracy of the information contained in this brochure, Fratelli Bertazzoni reserves the right to change any part of the information at any time without notice.

Fratelli Bertazzoni, Bertazzoni and the winged wheel brand icon are registered trademarks of Bertazzoni Spa.