



Professional Series stainless steel double oven.

FEATURES & BENEFITS

Metal knobs, professional handles and analog clock coordinate with Thermador's Professional Series

Massive 4.7 cu. ft. oven cavity

Concealed bake element for enlarged capacity

Exclusive, dishwasher-safe, professional-quality rotisserie supports up to 12 lbs.

Totally recessed 5,000-watt, 12 pass MaxBroil™ element offers the most powerful and even heating

New True Convection baffle system directs heat precisely and evenly

New Speed Convection mode reduces cooking time for frozen foods up to 30%

Ball bearing full-extension telescopic rack

SKU	PO302
Size	30"
Type	Double
Color-Stainless Steel	PO302
Cavity Size*	4.7 cu. ft.
Control	Professional-Style
Display	-
MAIN FEATURES	
Professional Design	■
True Convection	Upper
Speed Convection	Upper
Rotisserie	Upper
MaxBroil	Upper
Convection Broil	-
Max Convection Broil	Upper
Convection Roast	Upper
Bake, Roast	Upper/Lower
Broil	Upper/Lower
Warm	Upper/Lower
Fast Preheat	-
Dehydrate	Upper
Meat Probe	-
Self-clean	■
Self-clean rack supports	■
Full Access® Telescopic Racks**	1
Professional-Style Racks	5
Porcelain Broiler Pan	■
Halogen Lighting Per Cavity	4
Concealed Bake Element	■

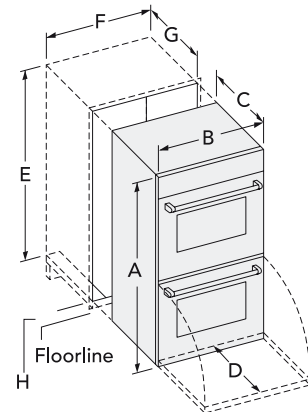

Model No.	Overall Dimensions				Cutout Dimensions***				Door Handle Projection	Dual-Rated 120/208-240V, 4 Wire, 60 Hz.	Amps
	A	B	C	D	E	F	G	H			
PO302	51 ³ / ₄	29 ³ / ₄	23 ⁷ / ₈	22	51 ¹ / ₈	28 ¹ / ₂	24	4 ³ / ₄ min	4 ¹ / ₁₆	■	40

BSH reserves the absolute and unrestricted right to change product materials and specifications, at any time, without notice. Consult the product's installation instructions for final dimensional data and other details. Applicable product warranty can be found in accompanying product literature (or you may contact your account manager for further details). **Notes:** All height, width and depth dimensions are shown in inches. *According to AHAM standards. **Available as separate accessory TLSCPRCK30. ***Please refer to installation instructions prior to making cutout.