

## QUICK USE & CARE



# Refrigerators

### SAFETY

**IMPORTANT SAFETY INFORMATION READ ALL INSTRUCTIONS BEFORE USING**



*GE Appliances Website*

*For more information on your refrigerator's operation, visit  
[www.GEAppliances.com](http://www.GEAppliances.com)*

### REFRIGERATOR SAFETY INFORMATION

**!** This is the safety alert symbol. This symbol alerts you to potential hazards that can kill or hurt you and others. All safety messages will follow the safety alert symbol and the word "DANGER", "WARNING", or "CAUTION". These words are defined as:

**! DANGER**

Indicates a hazardous situation which, if not avoided, **will** result in death or serious injury.

**! WARNING**

Indicates a hazardous situation which, if not avoided, **could** result in death or serious injury.

**! CAUTION**

Indicates a hazardous situation which, if not avoided, **could** result in minor or moderate injury.

### IMPORTANT SAFETY INSTRUCTIONS

**! WARNING**

To reduce the risk of fire, explosion, electric shock, or injury when using your refrigerator follow these basic safety precautions:

- This refrigerator must be properly installed and located in accordance with the Installation Instructions before it is used.
- Unplug the refrigerator before cleaning and making repairs.
- NOTE: Repairs must be performed by a qualified Service Professional.
- Replace all parts and panels before operating.
- Because of potential safety hazards under certain conditions, we strongly recommend against the use of an extension cord. However, if you must use an extension cord, it is absolutely necessary that it be a UL-listed (in the United States) or a CSA certified (in Canada), 3-wire grounding type appliance extension cord having a grounding type plug and outlet and that the electrical rating of the cord be 15 amperes (minimum) and 120 volts.
- To prevent suffocation and entrapment hazards to children, Remove the fresh food and freezer doors from any refrigerator before disposing of it or discontinuing its use.
- Do not store or use gasoline or other flammable vapors and liquids in the vicinity of this or any other appliance.
- Power to the refrigerator cannot be disconnected by any setting on the control panel, refrigerator must be unplugged to remove power.
- Do not allow children to climb, stand or hang on the door handles or the shelves in the refrigerator. They could seriously injure themselves.
- In refrigerators with automatic icemakers, avoid contact with the moving parts of the ejector mechanism, or with the heating element that releases the cubes. Do not place fingers or hands on the automatic icemaking mechanism while the refrigerator is plugged in.
- Do not clean glass shelves or covers with warm water when they are cold. Glass shelves and covers may break if exposed to sudden temperature changes or impact, such as bumping or dropping. Tempered glass is designed to shatter into many small pieces if it breaks.
- Keep fingers out of the "pinch point" areas; clearances between the doors and between the doors and cabinet are necessarily small. Be careful closing doors when children are in the area.
- Do not touch the cold surfaces in the freezer compartment when hands are damp or wet, skin may stick to these extremely cold surfaces.
- Do not refreeze frozen foods which have thawed completely.
- Use a sturdy glass when dispensing ice (on models with ice dispenser)

**FEATURES (not all features are on all models)**

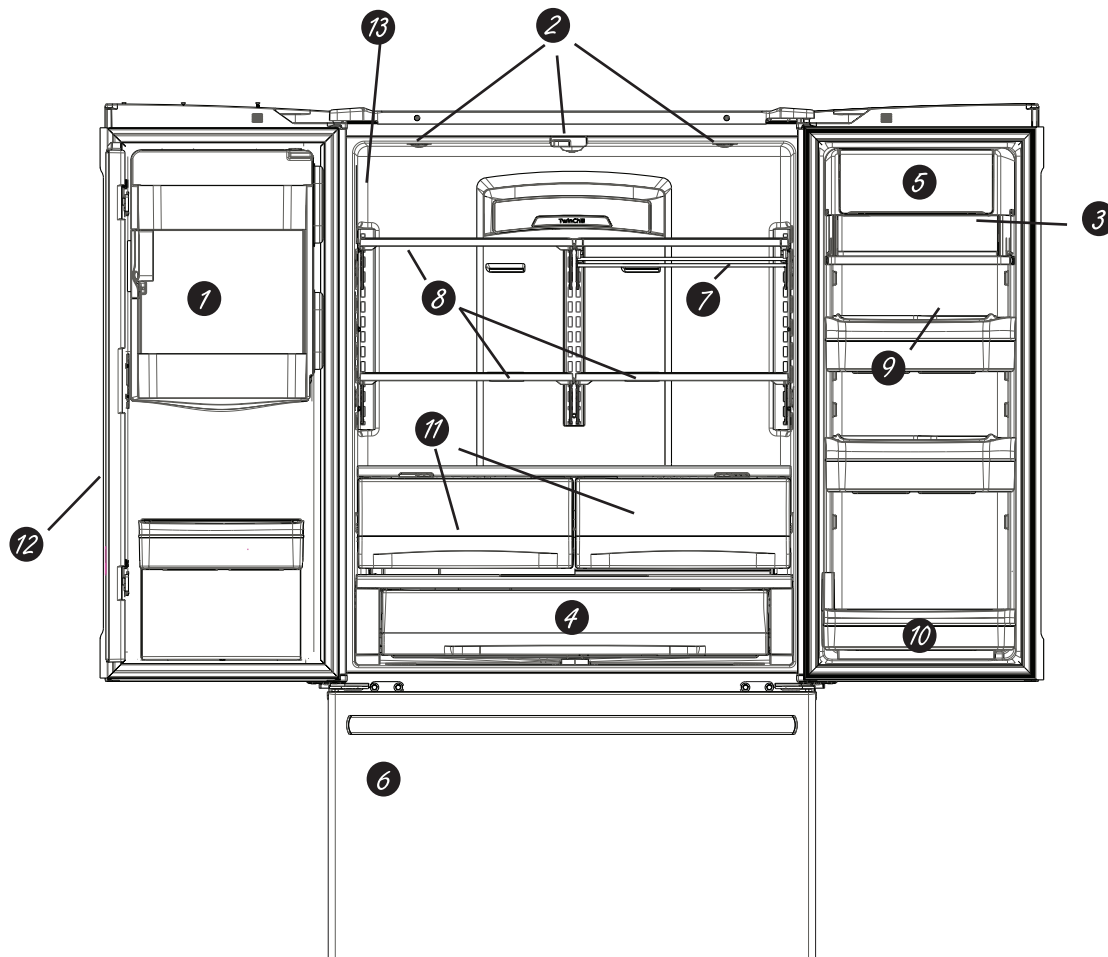

**1 Space-saving icemaker**

Icemaker and bin are located on the door creating more usable storage space.

**2 Showcase LED lighting**

LED lighting is positioned throughout the interior to spotlight areas in the refrigerator. LEDs are located under the fresh food door to light the freezer when opened.

**3 Drop-down tray**

Allows for extra door storage when you need it and tucks away when you don't.

**4 Full-width electronic temperature controlled drawer**

Adjustable temperature control bin that can accommodate larger items

**5 Dairy bin**

Separate compartment for your items.

**6 Dual icemaker/utility bin**

An icemaker in both compartments gives you more ice whenever you need it or a utility bin designed for flexible storage.

**7**

Functions as a normal full-sized shelf when needed and easily slides back to store tall items below.

**8 Spillproof shelves**

Designed to capture your spills for easier clean up.

**9 Removeable condiment bin**

Separate bin designed for easy removal and storage.

**10 Removeable door bin**

Can be removed for those with a wall limiting the door opening.

**11 Humidity zone**

Separate bins for produce storage.

**12 In-the-door filter (select models)**

Located in the door for more available space in the fresh-food section and easy replacement.

**13 Water filter (select models)**

Filters water & Ice

**QuickSpace™ shelf**

**⚠ WARNING Suffocation and child entrapment hazard.**

Remove fresh-food and freezer doors from the refrigerator, prior to disposal. Failure to do so can result in child entrapment which can lead to death or brain damage.

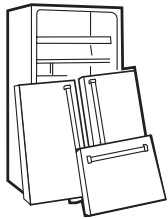
**IMPORTANT:**

Child entrapment and suffocation are not problems of the past. Junked or abandoned refrigerators are still dangerous even if they will sit for "just a few days." If you are getting rid of your old refrigerator, please follow the instructions below to help prevent accidents.

All refrigeration products contain refrigerants, which under federal law must be removed prior to product disposal. If you are getting rid of an old refrigeration product, check with the company handling the disposal about what to do.

**Before You Throw Away Your Old Refrigerator or Freezer:**

- Take off the fresh food and freezer doors.
- Leave the shelves in place so that children may not easily climb inside.

**Refrigerants****INSTALLATION****⚠ WARNING Explosion Hazard.**

Keep flammable materials and vapors, such as gasoline, away from refrigerator. Failure to do so can result in fire, explosion, or death.

**CONNECTING ELECTRICITY****⚠ WARNING Electrical Shock Hazard.**

Plug into a grounded 3-prong outlet

Do not remove the ground prong

Do not use an adapter

Failure to follow these instructions can result in death, fire, or electrical shock.



**Do not, under any circumstances, cut or remove the third (ground) prong from the power cord. For personal safety, this appliance must be properly grounded.**

The power cord of this appliance is equipped with a 3-prong (grounding) plug which mates with a standard 3-prong (grounding) wall outlet to minimize the possibility of electric shock hazard from this appliance.

Have the wall outlet and circuit checked by a qualified electrician to make sure the outlet is properly grounded.

Where a standard 2-prong wall outlet is encountered, it is your personal responsibility and obligation to have it replaced with a properly grounded 3-prong wall outlet. Do not use an adapter.

The refrigerator should always be plugged into its own individual electrical outlet which has a voltage rating that matches the rating plate.

A 115 Volt AC, 60 Hz, 15- or 20-amp fused, grounded electrical supply is required.

This provides the best performance and also prevents overloading house wiring circuits which could cause a fire hazard from overheated wires.

Never unplug your refrigerator by pulling on the power cord. Always grip plug firmly and pull straight out from the outlet.

Repair or replace immediately all power cords that have become frayed or otherwise damaged. Do not use a cord that shows cracks or abrasion damage along its length or at either end.

When moving the refrigerator away from the wall, be careful not to roll over or damage the power cord.

## FEATURES (not all features are on all models)

- 1 Door ice bin**
1. Open left fresh food door.
  2. Pull down latch to release bin door.
  3. Using handhold lift bin up and out to clear locators in bottom of bin.
  4. Reverse to reinstall.

- 2 Drop down dairy bin**
1. Open right fresh food
  2. Depress both buttons on lower sides of bin and bin will drop down.
  3. Reverse to reinstall.

- 3 Door ice/water filter**  
**Remove bypass filter plug**
1. Open filter door and gently rotate up and pull straight out to remove bypass plug.

### Installing the filter cartridge

1. Align top of filter cartridge holder and push until cartridge is fully seated.
2. While continuing to ensure cartridge is fully seated in the holder, gently rotate the filter inward until it can no longer rotate. If rotation is difficult, check to ensure filter is properly aligned and fully seated within holder. Run water from the dispenser (approx. 2 gallons or about 5 minutes) to clear any particles and remove air from the system.
3. Reset Filter Status.

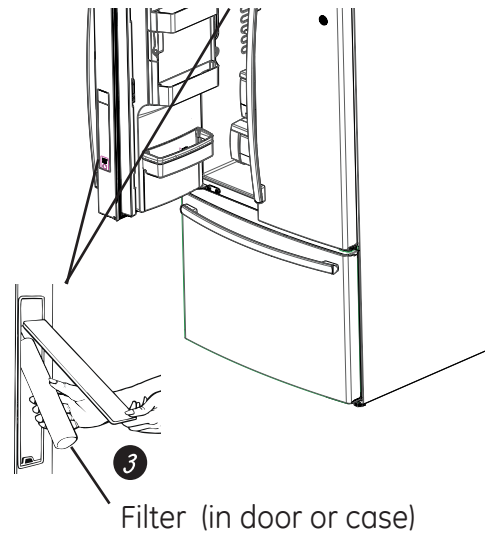
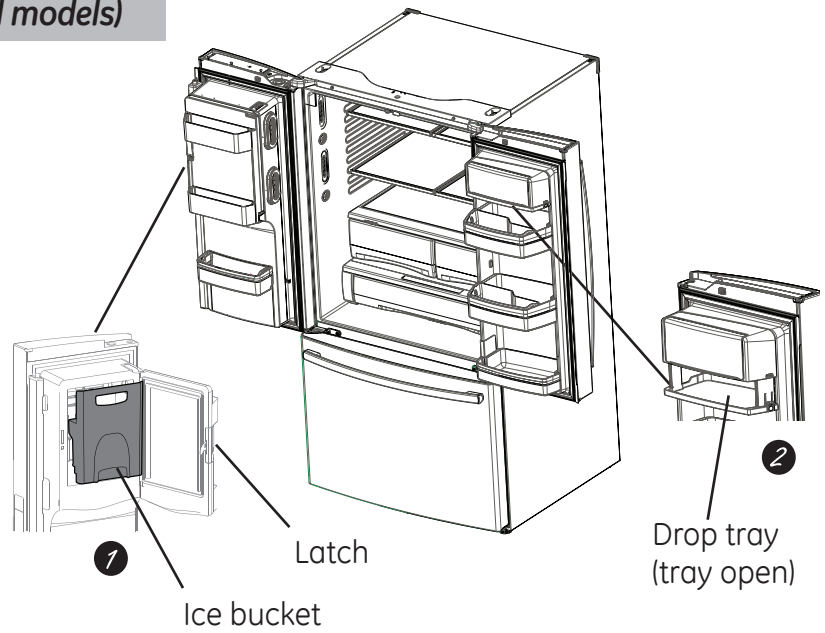

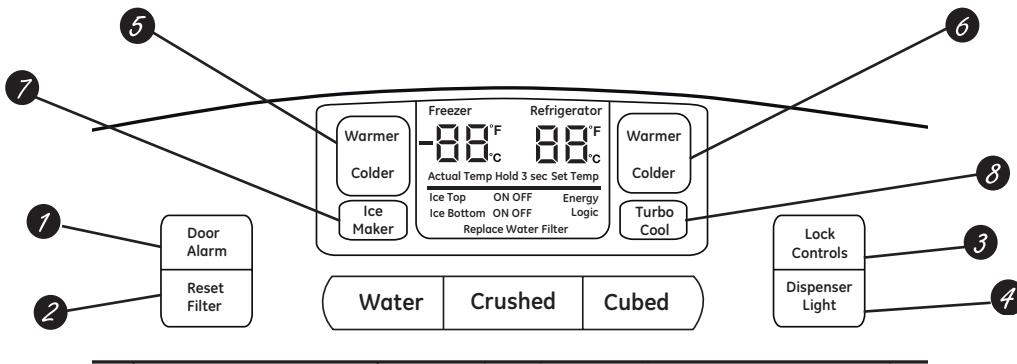

- 1 Alarm**  
Sounds to alert when the freezer or fresh food doors have been left open.
- 2 Reset Filter**  
Hold for 3 seconds after replacing filter.
- 3 Lock**  
Press and hold 3 seconds to lock out ice and water dispenser and all feature and temperature buttons.
- 4 LED dispenser light**  
LED lighting that can be turned on/off to light your dispenser.
- 5 Freezer temp control**  
Adjust freezer compartment temperature
- 6 Refrigerator temp control**  
Adjust fresh food compartment temperature
- 7 Ice maker control (select models)**  
Turn your ice makers on/off
- 8 TurboCool™ setting**  
Activate TurboCool to quickly restore refrigerator temperature after frequent door openings.

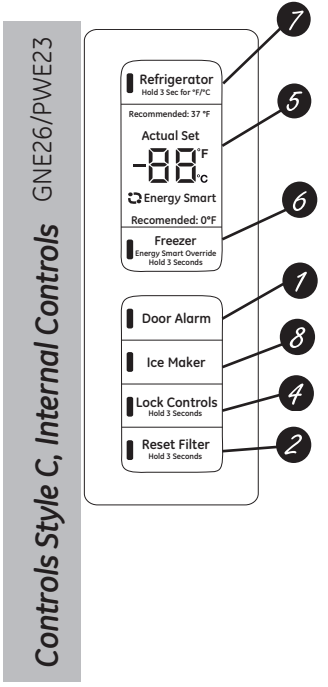

Controls Style C, Internal Controls GNE26/PWE23

## Normal operating sounds.



Newer refrigerators sound different than older refrigerators. Modern refrigerators have more features and use newer technology. Do you hear what I hear? These sounds are normal.

**HUMMM...**  
**WHOOSH...**

- The new high efficiency compressor may run faster and longer than your old refrigerator and you may hear a high-pitched hum or pulsating sound while it is operating.
- You may hear a whooshing sound when the doors close. This is due to pressure equalizing within the refrigerator.
- After dispensing ice, a motor will close the ice chute to keep warm room air from entering the ice bucket, maintaining ice at a freezing temperature. The humm of the motor closing the ice chute is normal, shortly after dispensing ice.



- You may hear the fans spinning at high speeds. This happens when the refrigerator is first plugged in, when the doors are opened frequently or when a large amount of food is added to the refrigerator or freezer compartments. The fans are helping to maintain the correct temperatures.
- The fans change speeds in order to provide optimal cooling and energy savings.

**CLICKS, POPS,**  
**CRACKS and SNAPS**

- You may hear cracking or popping sounds when the refrigerator is first plugged in. This happens as the refrigerator cools to the correct temperature.
- Expansion and contraction of cooling coils during and after defrost can cause a cracking or popping sound.
- On models with an icemaker, after an icemaking cycle, you may hear the ice cubes dropping into the ice bucket.
- On models with a dispenser, during water dispense, you may hear the water lines move at initial dispense and after dispenser button is released.

**WATER SOUNDS**



- The flow of refrigerant through the cooling coils may make a gurgling noise like boiling water.
- Water dropping on the defrost heater can cause a sizzling, popping or buzzing sound during the defrost cycle.
- A water dripping noise may occur during the defrost cycle as ice melts from the evaporator and flows into the drain pan.
- Closing the door may cause a gurgling sound due to pressure equalization.

**SERVICE** Before you call for service, review the detailed troubleshooting tips in the Owner's manual. If needed, service can be scheduled by visiting us online [GEAppliances.com](http://GEAppliances.com) or calling 800.ge.CARES 800.432.2737

## Truth or Myth

Truth or Myth?	Answer	Explanation
The refrigerator water filter may require replacement, even though the filter indicator has not turned red, or reads "Filter Expired."	TRUE	The water filter indicator will indicate the need to replace the water filter every six months. Water quality varies from city to city; if water flow from the dispenser slows, or ice production decreases, the water filter should be replaced, even though the filter indicator may not indicate the need for replacement.
The automatic ice maker in my refrigerator will produce ice when the refrigerator is plugged in to a power receptacle.	MYTH	The refrigerator must be connected to water, and the ice maker must be turned on. Make sure the ice maker is turned on, only after the water line is connected and water is turned on. The icemaker can be turned <b>on/off</b> from either the controls or at the icemaker depending on your model and ensure the ice maker is on, as indicated on the refrigerator control panel.
After the refrigerator has been plugged in and connected to water, I will immediately have unlimited chilled water available from the water dispenser.	MYTH	The water dispenser tank located inside the refrigerator stores water for dispensing. The water in this tank requires 24 hours to chill after installation. High usage conditions will not allow time for the water to chill.
After water dispenses, a few drops of water are normal.	TRUE	A few drops of water may fall from the dispenser, after the dispenser paddle has been released. To minimize the drops, remove the glass slowly from the dispenser.
I will never see frost inside the freezer compartment.	MYTH	Frost inside the freezer typically indicates that the door is not properly sealed, or has been left open. If frost is found, clear the frost using a plastic spatula and towel, then check to ensure that no food packages or containers are preventing the freezer door from closing. Check the refrigerator control panel to ensure the door alarm is on.
When the refrigerator is installed, or after replacing the water filter, I must dispense water for five minutes.	TRUE	A newly installed refrigerator or water filter contain air in the water lines. Press the dispenser paddle for at least 5 minutes to remove air from the water line, and flush the filter.
I can fill any container using auto fill.	MYTH	Auto fill detects the rim of the container, to determine how much water to dispense. If a container is not detected, try repositioning the container. If a container will not fill properly, try a different container.
To fill the ice bucket to the maximum capacity, I should dispense 12 and 18 hours after installation.	TRUE	Dispensing 3-4 cubes 12 hours and 18 hours after installation, allows ice to disperse within the ice bucket, which in turns calls on the ice maker to produce additional ice. Normal ice production = 100 cubes in 24 hours.
I can use the water filter bypass plug to determine if the filter requires replacement.	TRUE	Decrease in flow from the water dispenser, or decreased ice production, may indicate the need to replace the water filter. Install the water filter bypass plug (provided with the refrigerator), and check flow from the dispenser. If water flow returns to normal with the bypass plug in place, replace the water filter.
The top of the refrigerator doors will always be aligned.	MYTH	Several things can affect the the fresh food door alignment, including the floor the refrigerator is installed on, and loading of doors. If the top of the fresh food doors are not aligned, use a 1/4" allen wrench to adjust the right hand door. The adjustment screw is located on the bottom right hand side of the door; open the freezer door to access the screw.
Refrigerator door handles can be easily tightened.	TRUE	If door handles are loose or have a gap, the handle can be adjusted using a 1/8" allen wrench, on set screws located on the ends of the handles.
Refrigerator start-up LCD does not display correctly	TRUE	If the Refrigerator has been setting in a cold environment the LCD may take time to display fully.
There maybe a odor and taste problems with your ice.	TRUE	After starting the icemaker throw away 24 hours of ice production to avoid odor and taste problems.

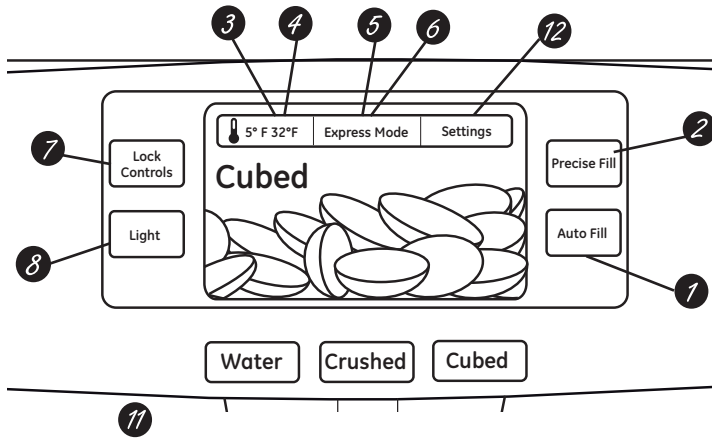

### 1 Hands-free Autofill

Hands-free Autofill uses sensors to monitor container height to automatically dispense filtered water without having to activate the paddle.

### 2 PreciseFill™ setting

Precisely dispenses filtered water in accurate measurements in ounces, cups, quarts, or liters using paddle.

### 3 Freezer temp control

Adjust freezer compartment temperature.

### 4 Fresh food temp control

Adjust fresh food compartment temperature.

### 5 TurboFreeze™ setting

Activate TurboFreeze to quickly restore freezer temperatures after frequent door openings.

### 6 TurboCool™ setting

Activate TurboCool to quickly restore refrigerator temperature after frequent door openings.

### 7 Lock controls

Press and hold 3 seconds to lock out ice and water dispenser and all feature and temperature buttons.

### 8 LED dispenser light

LED lighting that can be turned on/off to light your dispenser.

### 9 Alarm

Sounds to alert when the freezer or fresh food doors have been left open.

### 10 Reset filter

Hold for 3 seconds after replacing the filter.

### 11 Photo upload

Insert memory stick to upload personal photos to the refrigerator LCD screen.

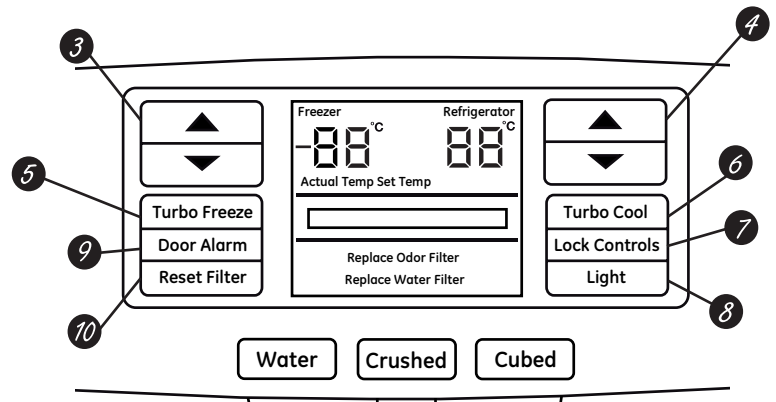

### 12 Additional settings:

- Smart Home ready
- Slideshow
- Reset filter
- Ice maker on/off
- Door alarm
- Sound control
- Metric/English units

#### Additional Modes

##### • Sabbath Mode

Press and hold lock & light simultaneously for 3 seconds to enter/exit Sabbath mode.

Activate Sabbath Mode to turn off interior lights, temperature control and advanced features. Compressor will run on a timed defrost when in Sabbath mode.

# Refrigerator Warranty. (For customers in the United States)



All warranty service provided by our Factory Service Centers, or an authorized Customer Care® technician. To schedule service, visit us on-line at [GEAppliances.com](http://GEAppliances.com), or call 800.GE.CARES (800.432.2737). Please have serial number and model number available when calling for service.

Staple your receipt here. Proof of the original purchase date is needed to obtain service under the warranty.

<b>For The Period Of:</b>	<b>GE Will Replace:</b>
---------------------------	-------------------------

**GE and GE PROFILE MODELS:**

One Year From the date of the original purchase	Any part of the refrigerator which fails due to a defect in materials or workmanship. During this limited one-year warranty, GE will also provide, free of charge, all labor and related service to replace the defective part.
Thirty Days (Water filter, if included) From the original purchase date of the refrigerator	Any part of the water filter cartridge which fails due to a defect in materials or workmanship. During this limited thirty-day warranty, GE will also provide, free of charge, a replacement water filter cartridge.

**GE PROFILE & CAFE MODELS ONLY:**

Five Years (GE Profile models only) From the date of the original purchase	Any part of the sealed refrigerating system (the compressor, condenser, evaporator and all connecting tubing) which fails due to a defect in materials or workmanship. During this limited five-year sealed refrigerating system warranty, GE will also provide, free of charge, all labor and related service to replace the defective part in the sealed refrigerating system.
--	--

**What GE Will Not Cover:**

- |  |  |
|--|--|
| <ul style="list-style-type: none"> <li>■ Service trips to your home to teach you how to use the product.</li> <li>■ Improper installation, delivery or maintenance.</li> <li>■ Failure of the product if it is abused, misused, or used for other than the intended purpose or used commercially.</li> <li>■ Loss of food due to spoilage.</li> <li>■ Replacement of house fuses or resetting of circuit breakers.</li> <li>■ Damage caused after delivery.</li> </ul> | <ul style="list-style-type: none"> <li>■ Replacement of the water filter cartridge, if included, due to water pressure that is outside the specified operating range or due to excessive sediment in the water supply.</li> <li>■ Replacement of the light bulbs, if included, or water filter cartridge, if included, other than as noted above.</li> <li>■ Damage to the product caused by accident, fire, floods or acts of God.</li> <li>■ Incidental or consequential damage caused by possible defects with this appliance.</li> <li>■ Product not accessible to provide required service.</li> <li>■ Damage caused by a non-GE Brand water filter.</li> </ul> |
|--|--|

**EXCLUSION OF IMPLIED WARRANTIES**—Your sole and exclusive remedy is product repair as provided in this Limited Warranty. Any implied warranties, including the implied warranties of merchantability or fitness for a particular purpose, are limited to one year or the shortest period allowed by law.

This warranty is extended to the original purchaser and any succeeding owner for products purchased for home use within the USA. If the product is located in an area where service by a GE Authorized Servicer is not available, you may be responsible for a trip charge or you may be required to bring the product to an Authorized GE Service location for service. In Alaska, the warranty excludes the cost of shipping or service calls to your home.

Some states do not allow the exclusion or limitation of incidental or consequential damages. This warranty gives you specific legal rights, and you may also have other rights which vary from state to state. To know what your legal rights are, consult your local or state consumer affairs office or your state's Attorney General.  
 Warrantor: General Electric Company. Louisville, KY 40225