

# PDWT480V

## GE Profile™ Built-In Dishwasher

### Dimensions and Installation Information (in inches)

#### Electrical Rating

Voltage AC.....	120
Hertz.....	60
Total connected load amperage.....	9.1
Calrod® heater watts max.....	875

For use on adequately wired 120-volt, 15-amp circuit having 2-wire service with a separate ground wire. This appliance must be grounded for safe operation.

**Installation Information:** Before installing, consult installation instructions packed with product for current dimensional data.

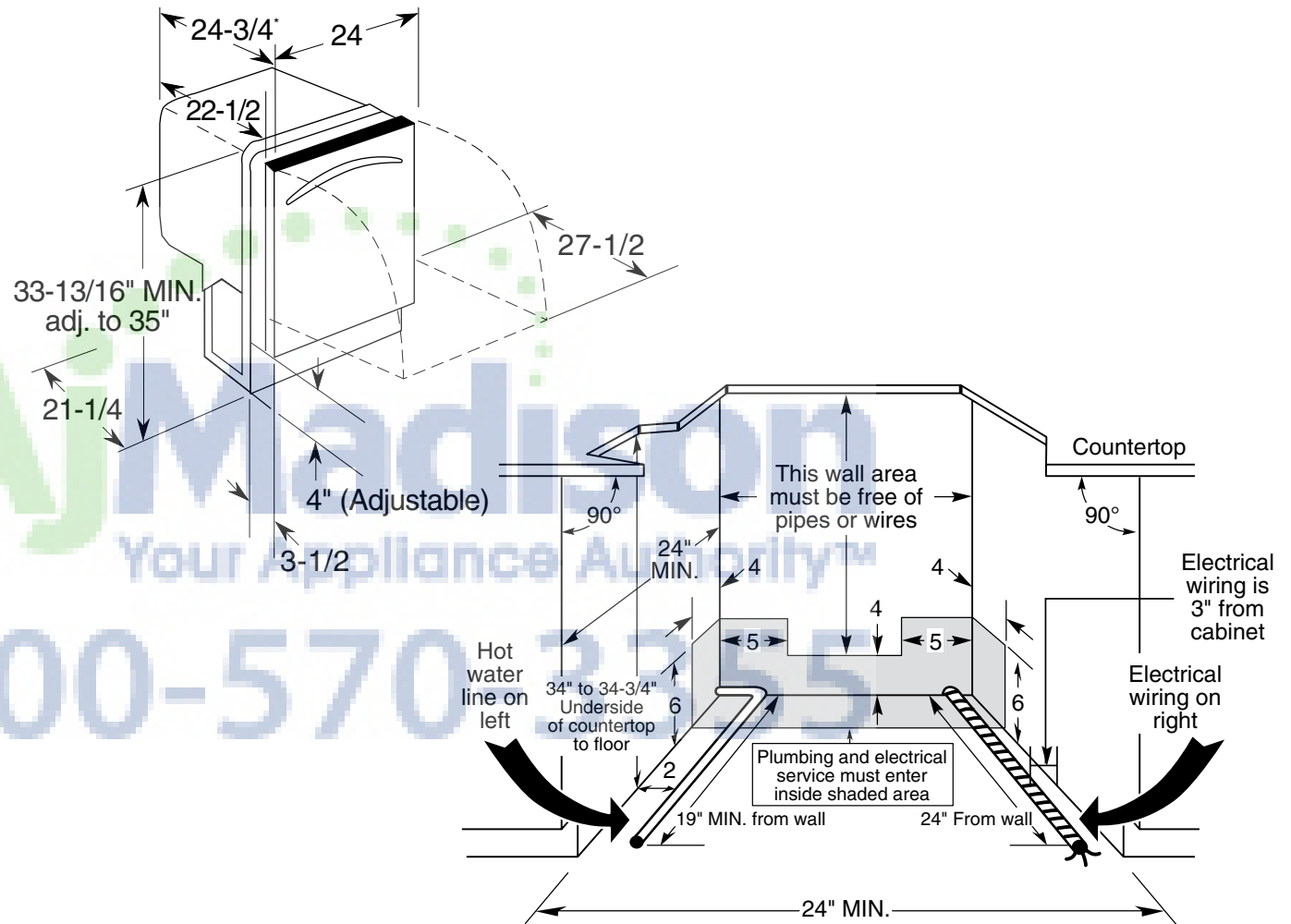

For answers to your Monogram®, GE Profile™ or GE® appliance questions, visit our website at [geappliances.com](http://geappliances.com) or call GE Answer Center® service, 800.626.2000.



Listed by Underwriters Laboratories



As an ENERGY STAR® partner, GE has determined that this product meets the ENERGY STAR guidelines for energy efficiency.

# PDWT480V

## GE Profile™ Built-In Dishwasher

### Features and Benefits

- 5-stage filtration with Piranha™ hard food disposer - 5 self-cleaning filters ensure clean dishes
- Dedicated silverware jets - Highly pressurized spray jets target the silverware area for improved cleaning
- Steam PreWash - Loosens tough soils before any cycle virtually eliminating the need for soaking or pre-rinsing dishes
- Fan assist dry with heated option and ActiveVent - A heating element heats the air inside while a hidden fan circulates the warm air to help dry dishes
- 48 dBA sound level - Nearly silent two-pump system cleans dirty dishes without disruption
- ENERGY STAR® qualified and CEE Tier II rated - Meets or exceeds federal guidelines for energy efficiency for year-round energy and money savings
- Eclipse black full-extension racks with ball-tip tines - Durable racks glide smoothly on ball-bearings for easy loading
- Four-position adjustable upper nylon rack with StemSafe™ - Provides loading versatility for today's dishes and up to 16 place settings
- Lower rack fold-down tines - Flexible loading options handle today's dishes and cookware of all shapes and sizes
- Upper rack deep bowl tines - Even oversized bowls fit perfectly in the top rack for easy cleaning
- Flexible racks - Designed for today's dishes and holds up to 16-place settings
- Two-pump system - One small pump for washing/rinsing and one small pump to remove soils provide excellent wash performance with reduced sound
- Model PDWT480VSS - Stainless steel

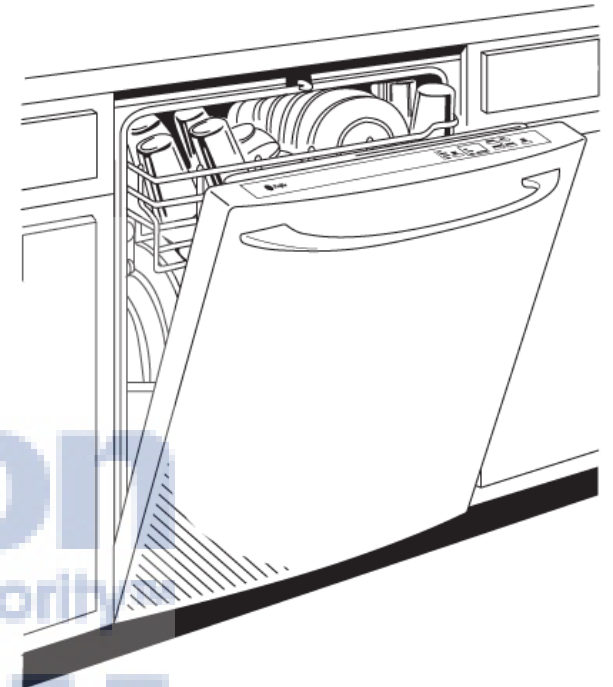

imagination at work