



# LARGER LOADS MEAN FEWER LOADS

WASH HUGE LOADS, BULKY ITEMS AND WASHABLE WOOL SWEATERS RIGHT AT HOME\*



**DUET® WASHERS  
& DRYERS**

*Shown: GHW9250MT (Biscuit)*



## The Capacity to Clean

### > Clean 16 Pairs of Jeans\*\* or a Single Silk Scarf

The Duet HT® washer is so big, you can clean up to 16 pairs of jeans in a single load\*\* and so gentle you can wash one silk scarf without worry. Automatic water leveling ensures just the right amount of water is used. Wash what you need, when you need it.



### > Incredible Capacity for Bulky Items

Save time by washing bulky items like blankets and comforters in your own laundry room instead of lugging them to the laundromat. The enormous wash basket and the new Bulky Items cycle (on the Duet HT® washer only) ensure thorough cleaning of these big loads.

The first washer in the USA certified by Woolmark for washable wools



## Trusted & Efficient

### > Multiple Gentle Cycles

No need to panic when your favorite blouse isn't in the closet. The customized Silk and Wool cycles (on Duet HT® washer only) and the Hand Washables cycle with Cradle Clean™ technology keep your fine fabrics looking fine—at your convenience—and reduces those last-minute trips to the dry cleaners.\*

### > Catalyst® Cleaning Action

Virtually forget about time spent looking for stains and pretreating them. Continuous Catalyst® cleaning action premixes detergent at the beginning of the cycle to break down protein- or oil-based stains. The result? Stains and heavy soil are removed *without* pretreating. The Duet HT® model even includes a heater for sanitary cleaning.



## Clean with Conservation

### > Use 68% Less Water and 67% Less Energy Every Year†

Duet® and Duet HT® washers exceed 2007 federal energy standards.

## The Duet® fabric care system works best as a pair

### Duet® Senseon™ Dryer

No other dryer can keep up with the speed, capacity and performance of the Duet® washer like a matching Duet® dryer. Dry loads in the same time it takes to wash them††—now, that's productivity!



*Shown with optional pedestals*

\*Always follow manufacturer's care instructions \*\*Various sizes †Savings compared to average conventional washers, normal cycle, 10 loads per week. ††Based on a 15 lb. load using Senseon™ HIGH cycle  
©Registered trademark /™Trademark of Whirlpool, U.S.A. All rights reserved. The Woolmark symbol is a registered trademark of The Woolmark Company. ©2003 Whirlpool Corporation, www.whirlpool.com, Form No. WWLL147, Printed in U.S.A. 06/03

# WHIRLPOOL® DUET® WASHER & DRYER FEATURES

## WASHER FEATURES

	DUET® GHW9100L	DUET HT® GHW9250M
<b>WASH SYSTEM</b>		
Wash/Spin Speed Combinations	Multiple	Multiple
Wash/Rinse Temperatures	3	5
Built-In Heater	—	Yes
Water Levels	Automatic	Automatic
Catalyst® Cleaning Action	Continuous	Continuous
ENERGY STAR® Qualified	Yes	Yes
AccuWash™ Temperature Control	Yes	Yes
Spin Speed (rpm)	up to 900	up to 1100
<b>AUTOMATIC CYCLES</b>		
Sanitary	—	Yes
Whitest Whites	Yes	Yes
Heavy Duty	Yes	Yes
Normal/Casual	Yes	Yes
Delicate/Casual	Yes	Yes
Silk	—	Yes
Woolmark Wool (Exclusive)	—	Yes
Bulky Items	—	Yes
30 Minute Quick Wash	—	Yes
Hand Washables	Yes	Yes
Soak	Yes	Yes
<b>WASH OPTIONS</b>		
Pre-Wash	—	Yes
Auto Soak	—	Yes
Extra Rinse	Yes	Yes
Delay Start	—	Yes
Add-A-Garment	Yes	Yes
<b>CONVENIENCE FEATURES</b>		
End-of-Cycle Signal	Yes	Adj. Long Tone
Bleach, Fabric, Detergent Dispenser	Yes	+ Prewash Detergent
Cycle Status Lights	Yes	Yes
<b>QUALITY FEATURES</b>		
SpillGuard™ Top	Yes	Yes
Wash Drum Colors	Stainless Steel* White with Dove Grey	Stainless Steel* White with Dove Grey/ Biscuit/Pewter

## DRYER FEATURES

	GE/GW9200L
<b>DRY SYSTEM</b>	
Capacity	Super Cap. Plus
Senseon™ Drying System	Yes
<b>TEMPERATURE SETTINGS</b>	
	5
<b>AUTOMATIC CYCLES</b>	
Heavy Duty	Yes
Normal	Yes
Casual	Yes
Delicate	Yes
Super Delicate	Yes
<b>OPTIONS</b>	
Wrinkle Shield™ Plus (120 Min.)	On/Off
<b>CONVENIENCE FEATURES</b>	
Reversible Door	Yes
Door Window	Yes
End-of-Cycle Signal	3-Position
Dry Rack	Yes
Drum Light	Yes
Quiet Dry™ Plus Sound Insulation	Yes

## Duet® washer & dryer dimensions

### A Big Washer & Dryer Need Additional Space

- The product measures 31-1/2" deep with door closed
- The product measures 54" deep with door open
- The dryer needs an additional 5-1/2" in depth for venting requirements (total of 37" deep), unless you purchase a special vent kit

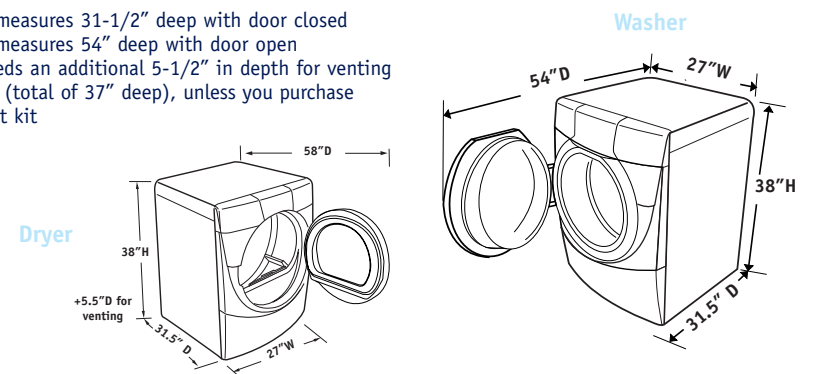

## Duet® pair installation options

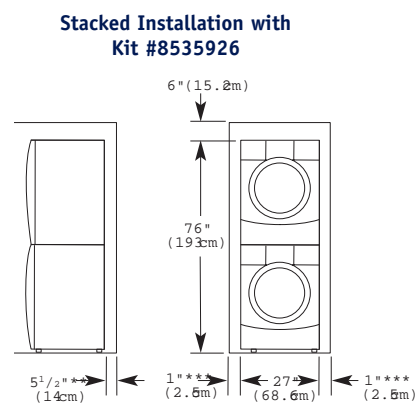

Optional Storage Drawer (Pedestal)  
Part No. LAB2700M

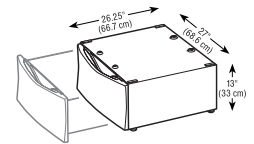

*Purchasing a Duet® washer and dryer is an exciting and rewarding investment. We encourage you to call our Duet® fabric care experts at 1-800-253-1301 for valuable installation and operating tips. Or visit <http://duet.whirlpool.com>.*

## The Duet HT® pair is now available in three colors:

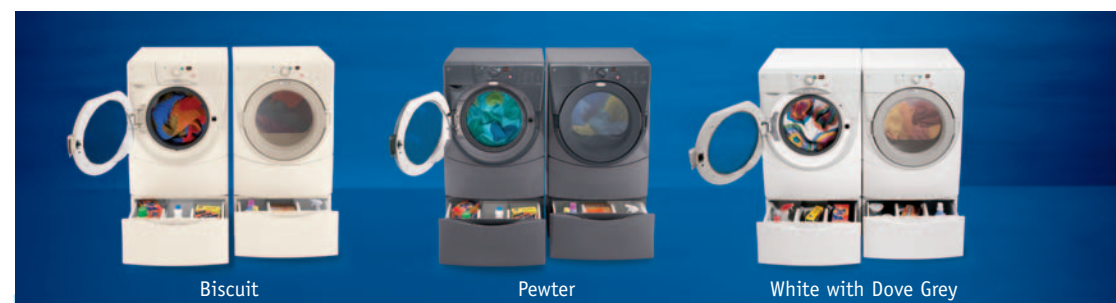

*Before purchasing these appliances, read important information about the estimated annual energy consumption or energy efficiency rating that is available from your retailer.*

As an ENERGY STAR® partner, Whirlpool Corporation has determined that products carrying the ENERGY STAR® emblem meet the ENERGY STAR® guidelines for energy efficiency.

\*Limited Lifetime Warranty

\*\*External exhaust elbow requires additional space

\*\*\*Wall, door and floor molding may require additional spacing

†See dealer or Use & Care guide for full details

**duet**®

FABRIC CARE SYSTEM

**Whirlpool**®  
Home Appliances  
JUST IMAGINE®

Visit us online at [www.whirlpool.com](http://www.whirlpool.com)