



Profile Washers

Safety Instructions 2, 3

Operating Instructions

Controls4

Cycle Options6

Help Feature13, 14

 Troubleshooter13

Loading and Using
the Washer17, 18

“My Cycles” Feature11, 12

Other Features15, 16

Quick Start Feature5

Stain Inspector7, 8

Summary Screen9, 10

Installation Instructions

Before You Begin19-21

Step-by-Step Instructions21-24

Switching the Washer and
Dryer Backsplashes25-28

Troubleshooting Tips29, 30

Consumer Support

Consumer Support Back Cover

Warranty 31

**Owner's Manual
and Installation
Instructions**

WPGT9350

**Write the model and serial
numbers here:**

Model # _____

Serial # _____

You can find them on the
rear cover of the washer
backsplash.



IMPORTANT SAFETY INSTRUCTIONS

READ ALL INSTRUCTIONS BEFORE USING.

▲ WARNING! *For your safety, the information in this manual must be followed to minimize the risk of fire or explosion, electric shock, or to prevent property damage, personal injury, or loss of life.*

WATER HEATER SAFETY

Under certain conditions, hydrogen gas may be produced in a water heater that has not been used for two weeks or more. Hydrogen gas can be explosive under these circumstances.

If the hot water has not been used for two weeks or more, prevent the possibility of damage or injury by turning on all hot water faucets and allowing them to run for several minutes. Do this before using any electrical appliance which is connected to the hot water system. This simple procedure will allow any built-up hydrogen gas to escape. Since the gas is flammable, do not smoke or use an open flame or appliance during this process.

PROPER INSTALLATION

This washer must be properly installed and located in accordance with the Installation Instructions before it is used. Installation Instructions are included in the back of this manual.

- Install or store where it will not be exposed to temperatures below freezing or exposed to the weather.
 - Properly ground washer to conform with all governing codes and ordinances. Follow details in Installation Instructions.
-

YOUR LAUNDRY AREA

- Keep the area underneath and around your appliances free of combustible materials such as lint, paper, rags, chemicals, etc.
- Close supervision is necessary if this appliance is used by or near children. Do not allow children to play on, with or inside this or any other appliance.

IMPORTANT SAFETY INSTRUCTIONS

READ ALL INSTRUCTIONS BEFORE USING.

▲ WARNING! *For your safety, the information in this manual must be followed to minimize the risk of fire or explosion, electric shock, or to prevent property damage, personal injury, or loss of life.*

WHEN USING THE WASHER

- Use this appliance only for its intended purpose as described in this Owner's Manual.
- Never reach into washer while it is moving. Wait until the machine has completely stopped before opening the lid.
- Do not mix chlorine bleach with ammonia or acids such as vinegar and/or rust remover. Mixing different chemicals can produce a toxic gas which may cause death.
- Do not wash or dry articles that have been cleaned in, washed in, soaked in, or spotted with combustible or explosive substances (such as wax, oil, paint, gasoline, degreasers, dry-cleaning solvents, kerosene) which may ignite or explode. Do not add these substances to the wash water. Do not use or place these substances around your washer or dryer during operation.
- The laundry process can reduce the flame retardancy of fabrics. To avoid such a result, carefully follow the garment manufacturer's wash and care instructions.
- To minimize the possibility of electric shock, unplug this appliance from the power supply or disconnect the washer at the household distribution panel by removing the fuse or switching off the circuit breaker before attempting any maintenance or cleaning. **NOTE:** Pressing START/STOP or POWER does **NOT** disconnect the appliance from the power supply.
- Never attempt to operate this appliance if it is damaged, malfunctioning, partially disassembled, or has missing or broken parts, including a damaged cord or plug.

WHEN NOT IN USE

- Turn off water faucets to relieve pressure on hoses and valves and to minimize leakage if a break or rupture should occur. Check the condition of the fill hoses; they should be replaced every 5 years.
- Before discarding a washer, or removing it from service, remove the washer lid to prevent children from hiding inside.
- Do not attempt to repair or replace any part of this appliance unless specifically recommended in this Owner's Manual, or in published user-repair instructions that you understand and have the skills to carry out.
- Do not tamper with controls.

READ AND FOLLOW THIS SAFETY INFORMATION CAREFULLY. SAVE THESE INSTRUCTIONS.

▲ WARNING! To reduce the risk of fire, electric shock, or injury to persons, read the **IMPORTANT SAFETY INSTRUCTIONS** before operating this appliance.

Throughout this manual, features and appearance may vary from your model.

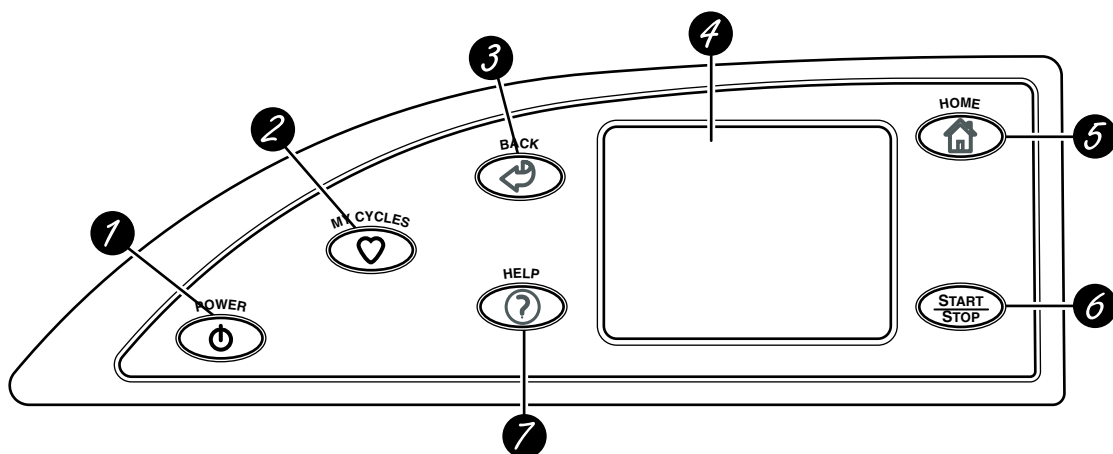

Features of the washer control panel

- 1 **POWER.** Press to “wake up” the display. If the display is active, press to put the washer into standby mode. You may also press the Touch Screen or any button to “wake up” the display.
NOTE: Pressing POWER does not disconnect the appliance from the power supply.
- 2 **MY CYCLES.** Press to use, create, rename, modify or delete custom wash cycles.
- 3 **BACK.** Press to return to the previous screen.
- 4 **TOUCH SCREEN.** Press the graphics on the interactive display to use the washer features.
Do not use sharp objects to press the Touch Screen.
NOTE: If the washer is inactive for 5 minutes, the Touch Screen will go into standby mode, and the display will be dark. Press the Touch Screen or any button to “wake up” the display.
- 5 **HOME.** Press to return to the “TOUCH TO SELECT WASH CYCLE” screen (Home Screen).
- 6 **START/STOP.** Press to start a wash cycle. If the washer is running, pressing once will pause the washer. Press again to restart the wash cycle.
NOTE: If the washer is paused and the cycle is not restarted within one hour, the washer will enter standby mode and the current wash cycle will be canceled.
- 7 **HELP.** Press to set machine preferences, to find help using the Touch Screen or to find troubleshooting tips for common washer problems.

Getting Started

If the Touch Screen is dark, press **POWER** or the Touch Screen to access the wash cycles menu.

- 1 Loosely load clothes no higher than the top row of holes in the washer tub. Overloading may reduce washer efficiency and possibly increase wrinkling.
- 2 Add a low-sudsing, high-efficiency detergent. Add diluted fabric softener, bleach or wash boost additives as desired.

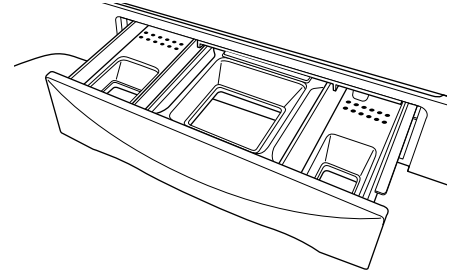

- 3 Select one of the five wash methods from the Home Screen:
 - Press **BY COLOR** to wash according to fabric color.
 - Press **BY GARMENT** to wash according to clothing type.
 - Press **BY FABRIC** to wash according to fabric type.
 - Press **SPECIAL CYCLES** to wash non-garment items, or to select a **rinse and spin** or **spin-only** cycle.
 - Press **STAIN INSPECTOR** to wash items with specific types of **stains**.



Home Screen

After selecting a wash method, use the Touch Screen to select a specific wash cycle to match your load.

- 4 Change any of the automatic settings, if desired, by pressing the Touch Screen and following the on-screen instructions.

By changing the settings you can:

 - Remove heavier soil.
 - Change the water temperature.
 - Change the wash action to Vigorous, Normal, Delicate or Hand Wash.
 - Set a Delay Start, Extended Spin, Presoak or Extra Rinse, or change the End-of-Cycle Signal volume.
 - Adjust time settings.

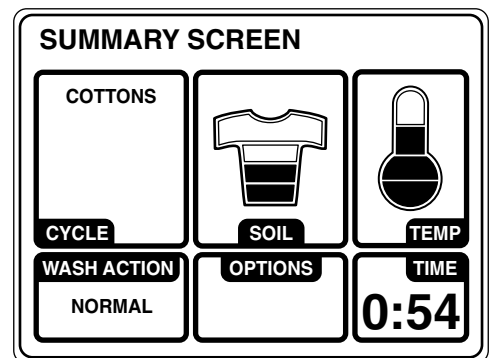

- 5 Close the lid and press **START**.

The washer will not fill unless the lid is closed.

After you press **START**, a Cycle Status screen will appear to indicate what stage of the cycle the washer is in and the time remaining in the cycle.



Wash Cycles

www.GEAppliances.com

If the Touch Screen is dark, press POWER or the Touch Screen to access the wash cycles menu.

The default cycle settings are based on standard load types. Always follow the fabric manufacturer's care label when laundering.

Washing by Color

Select By Color to wash loads sorted by color.

COLOR CYCLES include:

- Bright/Dark Colors
- Light Colors
- Mixed Colors
- New Colors
- Whites

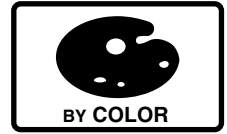

Washing by Garment Type

Select By Garment to wash loads sorted by garment type.

GARMENT CYCLES include:

- Athletic Wear
- Blouses
- Delicates
- Dress Shirts
- Easy Care
- Everyday Wear/Casual
- Jackets/Coats
- Jeans
- Khakis
- Knits
- Lingerie
- Mixed Garments
- Play Clothes
- Sweaters
- Swimwear
- Underwear
- Silks (Washable)



Washing by Fabric Type

Select By Fabric to wash loads sorted by fabric type.

FABRIC CYCLES include:

- Blends
- Cottons
- Delicates
- Knits
- Polyester
- Silks (Washable)



Washing Using the Special Cycles

Select SPECIAL CYCLES to wash loads of nongarment items or to select a rinse and spin or spin-only cycle.

SPECIAL CYCLES include:

- Blankets (Cotton)
- Blankets (Other)
- Comforter
- Super Clean
- Pet Bedding (Washable)
- Handwash Woolite® HE
- Rinse and Spin
- Sheets
- Sneakers
- Spin Only
- Throw Rugs (Washable)
- Towels
- Quick Clean



Washing Using the Stain Inspector

The **Stain Inspector** provides pretreatment tips and optimum washing for specific types of stains.

You select the specific stain, fabric type and color, and the washer creates the wash cycle for treating the stain.

Example: Washing a chocolate-stained, white cotton shirt

- 1 Press **STAIN INSPECTOR**.



- 2 Read and follow the instructions on the Touch Screen before treating the fabric.



- 3 Select **FOOD/DAIRY/COOKING** from the list of stain categories and select **CHOCOLATE** from the list of stains.

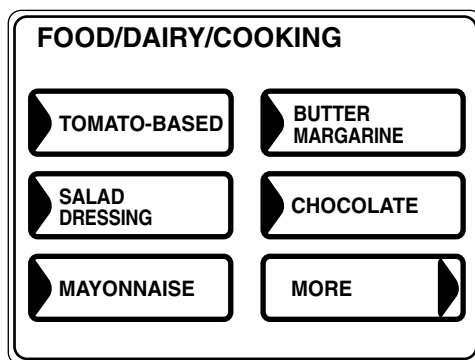

You can find additional stain categories and stains by pressing **MORE** in the lower right corner of the Touch Screen.

- 4 Press the **HELP** button to find pretreatment information for the specific type of stain.

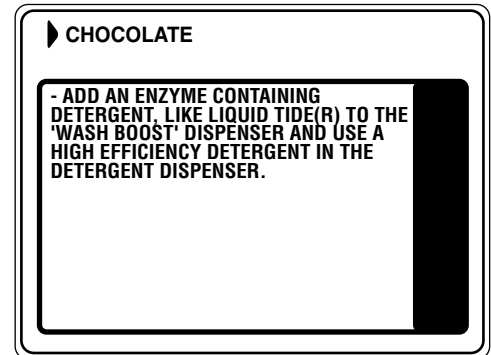

- 5 Select **COTTONS** from the list of fabric types, and select **WHITES** from the list of colors.
- 6 Fill the detergent tray with a low-sudsing, high-efficiency liquid detergent such as Tide® HE. Fill the Wash Boost tray with the proper pre-treatment additive.

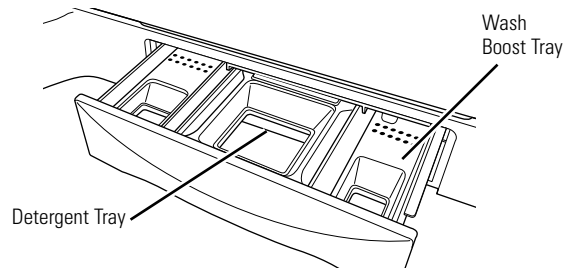

- 7 Place the stained garment(s) in the washer first; then add the rest of the load. For best stain removal, only wash items with stains matching your selection.

- 8 Press **START**.

The washer will run a Wash Boost presoak cycle prior to the main wash cycle.

NOTE: For some stain cycles, the water temperature for the presoak cycle may not be the same as the water temperature for the main wash cycle.

IMPORTANT: Check to make sure the stain is completely removed before placing the garment in the dryer.

Stain Selections

Below is a listing of the stain selections available on the washer Touch Screen. For additional information on handling these types of stains, visit the Tide® Stain Detective at www.tide.com/staindetective.

Stain Selections

Beverages

- Alcoholic beverages
- Coffee
- Fruit juice
- Kool-Aid®
- Milk
- Soda
- Tea
- Water
- Wine

School/Office/Home

- Adhesive tape
- Crayon
- Glue (synthetic)
- Glue (white/common)
- Ink
- Mildew
- Paint (water-based)
- Paint (oil-based)
- Pencil mark
- Rubber cement
- Wite-out®

Food/Dairy/Cooking

- Animal fat
- Baby formula
- Butter/margarine
- Chocolate
- Cooking oil
- Cream/cheese sauce
- Egg
- Gravy
- Grease
- Mayonnaise
- Milk
- Mustard
- Pudding
- Salad dressing
- Tomato-based
- Vegetable oil

Heavy Oils

- Motor oil
- Ointment/salve

Outdoor

- Dingy white socks
- Grass
- Mud/dirt
- Clay
- Rust/iron

Personal

- Baby stains
- Blood
- Feces
- Perspiration
- Urine
- Vomit

Cosmetics

- Chap Stick®
- Deodorant/antiperspirant
- Lipstick
- Lotions
- Makeup (oil-based)
- Makeup (water-based)

Specialty Stains

- Adhesive tape
- Asphalt/tar
- Glue (synthetic)
- Ink
- Pine sap
- Rubber cement
- Silly Putty®

Waxes

- Candle wax
- Chap Stick®
- Crayon

Summary Screen

www.GEAppliances.com

About the Summary Screen

After selecting a wash cycle, the Summary Screen displays the automatic settings for the cycle you have chosen. You can adjust these by touching the screen location for any of the settings shown.

If you change any of the automatic settings, you can save the new settings as a custom “My Cycle” by pressing the **MY CYCLES** button and choosing **SAVE CURRENT SETTINGS**.

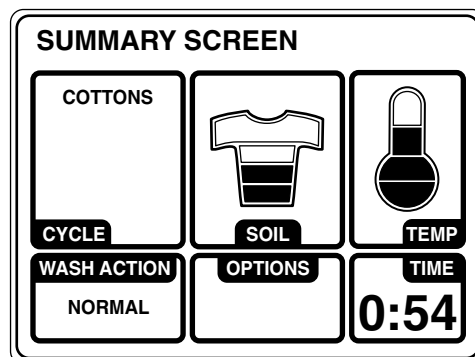

Changing the Soil Level

Changing the soil level increases or decreases the wash time to remove different amounts of soil.

To change the soil level, touch **SOIL** on the Touch Screen; then use the arrows to select more or less soil. Press **OK** when you have reached the desired setting.

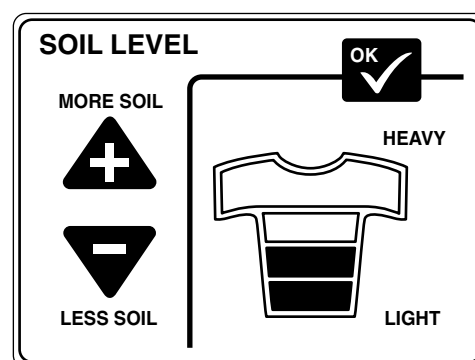

Changing the Wash Temperature

Changing the temperature changes the wash and presoak temperatures only. The final rinse will always be a cold rinse.

Follow the fabric manufacturer’s care label when selecting the wash temperature.

To change the wash temperature, touch the **TEMP** pad on the Touch Screen; then use the arrows to select a higher or lower temperature. Press **OK** when you have reached the desired setting.

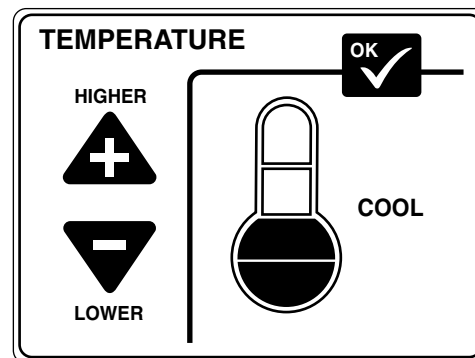

Changing the Wash Action

Changing the wash action changes the wash and spin speeds of the cycle.

Always follow the fabric manufacturer’s care label when changing the wash action.

To change the wash action, touch **WASH ACTION** on the Touch Screen; then select the desired setting.

Typically, slower spin speeds result in less water removed from clothes.

| Wash Action | Wash Speed | Spin Speed |
|-------------|------------|------------|
| Normal | Medium | Fast |
| Vigorous | Fast | Fast |
| Delicate | Slow | Slow |
| Hand Wash* | Extra Slow | Extra Slow |



*Use a low-sudsing, high-efficiency, gentle liquid detergent such as Woolite® HE.

About the Wash Options

The Wash Options allow you to set options for the current wash cycle only. After you have made all desired changes, press **OK**.

Delay Start – Use to delay the start of your washer. Press **DELAY START** to change the delay time.

Presoak – Soaks the clothes before beginning the wash cycle. Press **PRESOAK** to change the soaking time.

Additives – Appears ONLY AFTER a presoak has been selected. Uses the contents of the Wash Boost dispenser tray for a presoak. When selected, the washer will drain after the presoak and fill again for the wash cycle. Press **ADDITIVES** to specify if you will NOT be using a Wash Boost additive or if you do not want the washer to drain after presoak.

Extra Rinse – Adds an additional cold rinse to the end of the wash cycle.

Signal – Alerts you that the cycle is complete. The clothes should be removed when the beeper goes off so wrinkles won't set in. Touch **SIGNAL** to select the volume or to turn the beeper off. The new volume will be saved as the default setting.

Extended Spin – Increases the length of the spin time to extract more water from your clothes.

NOTE: The water level will vary depending on the load size and type. The washer uses adaptive filling and load sensing to provide the appropriate water level for effective and efficient wash performance and energy usage.

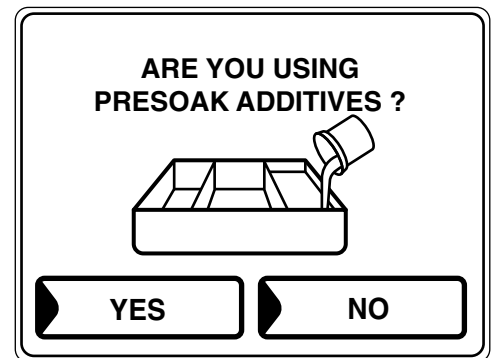
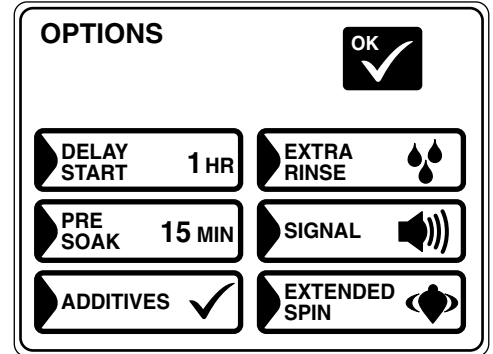

Adjusting the Time Settings

You can adjust the length of the wash cycle by changing the cycle time, adding a Delay Start or adding an Extending Spin.

Cycle Time – Press **CYCLE TIME**; then use the arrows to select more or less time.

Delay Time – Use to add a Delay Start to the beginning of the wash cycle. Press **DELAY TIME**; then set the DELAY START time in the OPTIONS menu.

Extended Spin – Increases the length of the spin time to extract more water from your clothes. Press **EXTENDED SPIN**; then select **EXTENDED SPIN** from the OPTIONS menu.

NOTE: After the wash cycle begins, you will not be able to change the Cycle Time or Delay Time. The washer will beep twice if you try to change the times after the cycle begins.

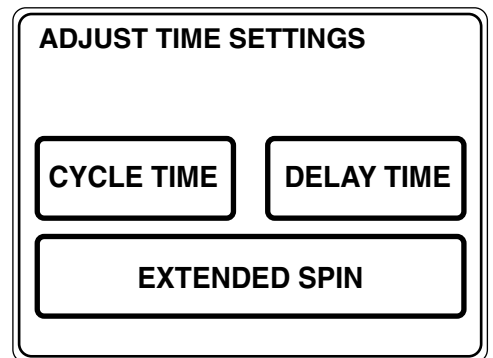

About the “My Cycles” Feature

The “My Cycles” feature allows you to create, store and reuse up to 6 custom cycles. Create your own cycles from scratch, or adjust the settings of a predefined wash cycle, then save for one-touch recall.

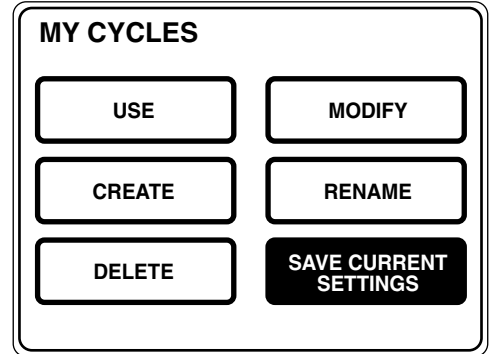

Creating and Using a “My Cycle”

You can create “My Cycles” two ways, by either modifying a predefined wash cycle or creating a cycle from your own combination of settings and options.

To build your own “My Cycle” from the Home Screen:

- 1 Press the **MY CYCLES** button.
- 2 Select **CREATE** from the Touch Screen menu.
- 3 Choose whether you want to modify a predefined cycle or create a new cycle.
- 4 If you are modifying a predefined cycle, select the wash cycle you wish to modify.
- 5 Change any of the automatic settings and select any options.
- 6 Press **SAVE** on the Touch Screen.
- 7 Using the keypad on the Touch Screen, type the name of your “My Cycle” and press **OK**.

To begin using your new “My Cycle” right away, select it from the Touch Screen menu and press **START**.

To save a current cycle as a “My Cycle” from the Summary Screen:

- 1 After setting a wash cycle, or after a wash cycle has just completed, press the **MY CYCLES** button.
- 2 Select **SAVE CURRENT SETTINGS** from the Touch Screen menu.
- 3 Using the keypad on the Touch Screen, type the name of your “My Cycle” and press **OK**.

To begin using your new “My Cycle” right away, select it from the Touch Screen menu and press **START**.

To use a “My Cycle” from the Home Screen:

- 1 Press the **MY CYCLES** button.
- 2 Select **USE** from the Touch Screen menu.
- 3 Select the cycle name from the Touch Screen menu.
- 4 Change any of the automatic settings and select any options.
- 5 Press **START**.

Modifying, Renaming or Deleting a “My Cycle”

To modify the settings of a “My Cycle” from the Home Screen:

- 1 Press the **MY CYCLES** button.
- 2 Select **MODIFY** from the Touch Screen menu.
- 3 Select the cycle name from the Touch Screen menu.
- 4 Change any of the automatic settings and select any options.
- 5 Press **SAVE** on the Touch Screen.

To rename a “My Cycle” from the Home Screen:

- 1 Press the **MY CYCLES** button.
- 2 Select **RENAME** from the Touch Screen menu.
- 3 Select the cycle name from the Touch Screen menu.
- 4 Using the keypad on the Touch Screen, type the name of your “My Cycle” and press **OK**.

To delete a “My Cycle” from the Home Screen:

- 1 Press the **MY CYCLES** button.
- 2 Select **DELETE** from the Touch Screen menu.
- 3 Select the cycle name from the Touch Screen menu.
- 4 Choose **YES** to delete the cycle or **CANCEL** to return to the list of “My Cycles.”

About the Help Feature

Pressing the **HELP** button from the Home Screen allows you to locate troubleshooting tips for common washer problems, to find help with using the Home Screen or to set machine preferences.

Pressing the **HELP** button while on any other screen allows you to find additional information on features found on that screen. Press **HELP**; then touch any pad on the Touch Screen for an explanation of that feature. To exit the feature, press **HELP** once to return to the previous screen or twice to exit Help.

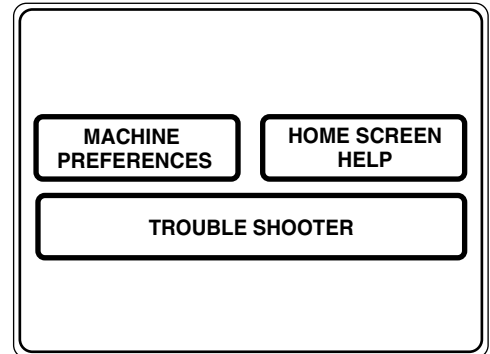

Using the Troubleshooter

To locate Troubleshooting Tips for common washer problems:

- 1 Press the **HELP** button.
- 2 On the Touch Screen, select **TROUBLE SHOOTER**.
- 3 On the Touch Screen, select the problem description from the list. You can use the arrows at the right of the screen to scroll up and down through the list of additional problems.
- 4 On the Touch Screen, select a possible cause for the problem and follow the on-screen instructions to find a solution.

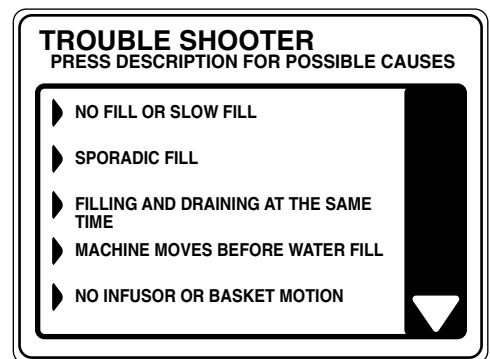

Finding Help Using the Home Screen

Pressing the **HELP** button, then selecting **HOME SCREEN HELP** allows you to find additional information on features found on the Home Screen. Touch any pad on the Touch Screen for an explanation of that feature. To exit the feature, press the **BACK** button.

Setting the Machine Preferences

The machine settings on the Help feature allow you to control the volume of the button beep and end-of-cycle signal, and turn the washer/dryer communication feature on or off.

Button Beep

The button beep controls the volume of the beep that is made when you press any of the buttons or the Touch Screen.

To change the volume of the button beep:

- 1 From the Home Screen, press the **HELP** button.
- 2 Select **MACHINE PREFERENCES** from the Touch Screen.
- 3 Select **BUTTON BEEP** from the Touch Screen.
- 4 Use the arrows to make the volume louder or softer, or to turn the beep off.
- 5 Select **OK** from the Touch Screen.

The new volume is now saved as the default setting.

Washer/Dryer Communication

Washer/Dryer communication allows your washer to send cycle information to your dryer to create a dry cycle that matches your wash load.

After the wash cycle is complete, communication begins once either the washer or dryer Touch Screen is activated.

Once the information is sent, your dryer will create the optimal dry cycle for your load.

To turn the Washer/Dryer Communication feature on or off:

- 1 From the Home Screen, press the **HELP** button.
- 2 Select **MACHINE PREFERENCES** from the Touch Screen.
- 3 Select **WASHER/DRYER COMMUNICATION** from the Touch Screen.
- 4 Touch the pad at the bottom of the Touch Screen to select **ON** or **OFF**.
- 5 Select **OK** from the Touch Screen.

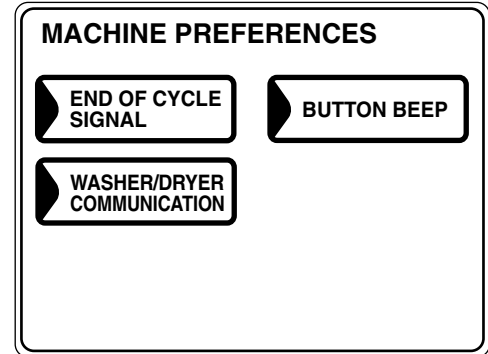

End-of-Cycle Signal

The End-of-Cycle signal alerts you when the cycle is complete.

To change the volume of the end-of-cycle signal:

- 1 From the Home Screen, press the **HELP** button.
- 2 Select **MACHINE PREFERENCES** from the Touch Screen.
- 3 Select **END OF CYCLE SIGNAL** from the Touch Screen.
- 4 Use the arrows to make the volume louder or softer, or to turn the signal off.
- 5 Select **OK** from the Touch Screen.

The new volume is now saved as the default setting.

Using the Liquid Bleach Dispenser

The bleach dispenser automatically dilutes and dispenses liquid chlorine bleach at the proper time in the wash cycle.

- 1 Check clothing care labels for special instructions.
- 2 Measure liquid bleach carefully, following instructions on the bottle.
 - *Never pour undiluted liquid chlorine bleach directly onto clothes or into the wash basket.*
 - *Do not pour powdered bleach into bleach dispenser.*
 - *Avoid overfilling or splashing when adding bleach to the dispenser. The maximum capacity of the bleach dispenser is one cup of bleach per wash cycle. Overfilling could result in early dispensing of bleach.*
- 3 Before starting the washer, pour measured amount of bleach directly into bleach dispenser. If you prefer to use powdered bleach, add it into the wash basket directly before adding clothes.

Do not mix chlorine bleach with ammonia or acids such as vinegar and/or rust remover. Mixing can produce a toxic gas which may cause death.

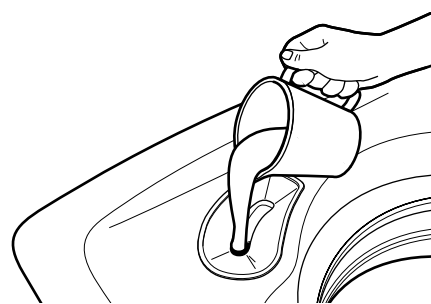

Using the Dispenser Drawer

The dispenser drawer contains 3 compartments:

- Liquid Fabric Softener
- Liquid or Powder Low-Sudsing, High-Efficiency Detergent
- Liquid Wash Boost Additives

The dispenser automatically dispenses additives at the proper time in the wash cycle.

- 1 Slowly open the dispenser drawer by pulling the drawer out until it stops.
 - 2 After adding laundry products, slowly close the dispenser drawer. Closing the drawer too quickly could result in early dispensing of additives.
- Avoid overfilling or splashing when adding laundry products to the dispenser. Doing so could result in early dispensing of laundry products.

At the end of the cycle, you may see water in the compartments. This is part of the normal operation of the washer.

NOTE: Do not use bleach in the dispenser drawer.

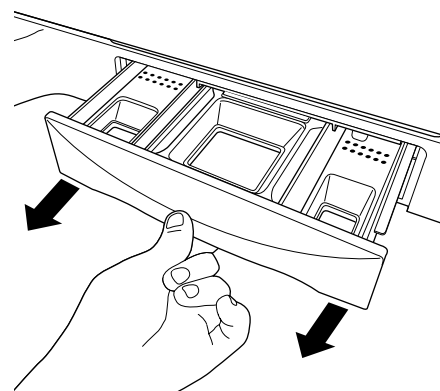

Adding Detergent

NOTE: Use only low-sudsing, high-efficiency detergent such as Tide® HE.

Add measured detergent to the detergent compartment of the dispenser drawer.

- **Do not exceed the maximum fill line.**

Detergent is flushed through the dispenser at the beginning of the wash phase. Either powdered or liquid detergent can be used.

When using liquid detergent, make sure the detergent box and insert are in place. For powdered detergent, remove both the detergent box and insert. **Powdered detergent will not dispense with the detergent box and insert in place.**

Detergent usage may need to be adjusted for water temperature, water hardness, size and soil level of the load. Avoid using too much detergent in your washer, as it can lead to oversudsing and detergent residue being left on the clothes.

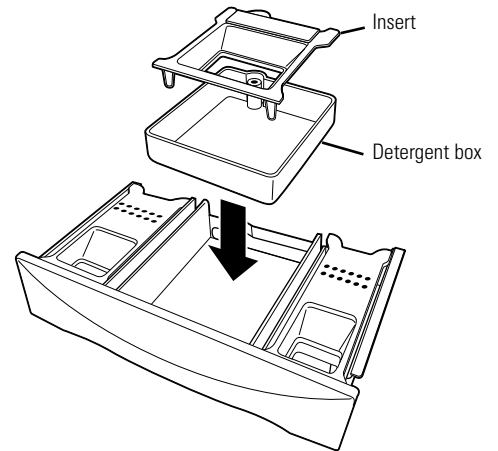

Adding Fabric Softener

If desired, pour the recommended amount of liquid fabric softener into the left-hand compartment.

Use only liquid fabric softener.

Dilute with water to the maximum fill line.

- **Do not exceed the maximum fill line.**

Overfilling can cause early dispensing of the fabric softener, which could stain clothes.

NOTE: Do not pour fabric softener directly on the wash load. It may stain the clothes.

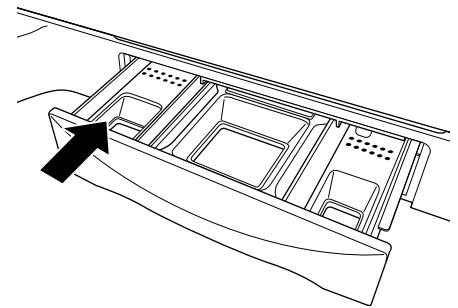

Adding Wash Boost Additives

The Wash Boost dispenser may be used to clean heavily soiled or stained garments more efficiently. Selecting **ADDITIVES** when setting a presoak sets a special "Wash Boost" that soaks, drains and spins, then refills the washer for the main wash cycle.

If **ADDITIVES** is not selected, the washer will not drain and refill after the presoak.

Place the additives for the Wash Boost setting in the right-hand compartment. Select an Extra Rinse to make sure all remaining detergent is removed from the wash load.

You may add low-sudsing, high-efficiency liquid detergent to this compartment when selecting a Stain Inspector cycle or when choosing a Presoak requiring special additives.

- **Do not exceed the maximum fill line to avoid oversudsing.**

Overfilling can cause early dispensing of presoak additives, which could result in damaged clothes.

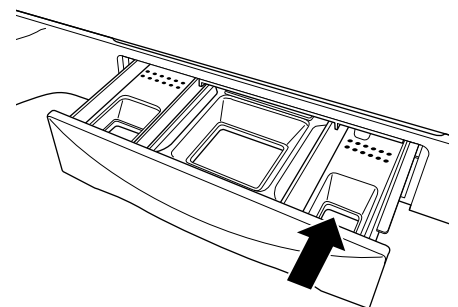

Always follow fabric manufacturer's care label when laundering.

Sorting Wash Loads

Sort by color (whites, lights, colors), soil level, fabric type (sturdy cottons, easy care, delicates) and whether the fabric produces lint (terry cloth, chenille) or collects lint (velveteen, corduroy).

Loading the Washer

Load dry items loosely, no higher than the top row of holes in the washer basket. Overloading may reduce washer efficiency and possibly increase wrinkling.

Bulky items should be placed as far down in the wash basket as possible for optimal results.

Always place buoyant items at the bottom of the wash basket.

The washer will automatically detect the load size. Because of the high-efficiency wash system, the water level may not completely cover the load. To add items after washer has started, lift the lid, add items and close the lid.

- *Do not wash fabrics containing flammable materials (waxes, cleaning fluids, etc.)*
- *The washer will not fill or operate with the lid open.*

Fabric Care Labels

Below are fabric care label "symbols" that affect the clothing you will be laundering.

Wash Labels

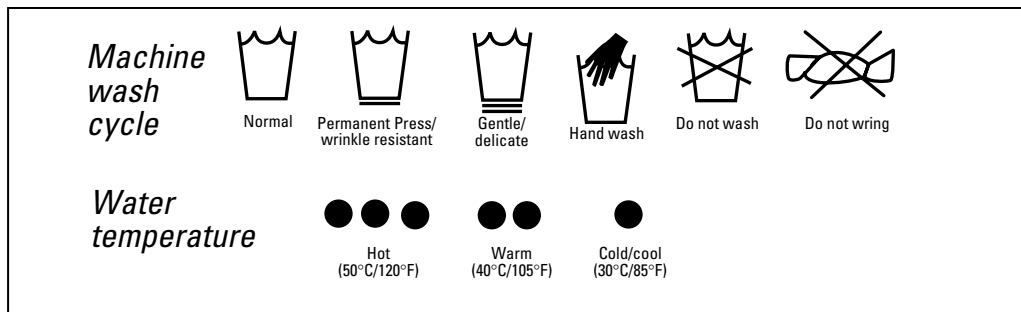

Dry Labels

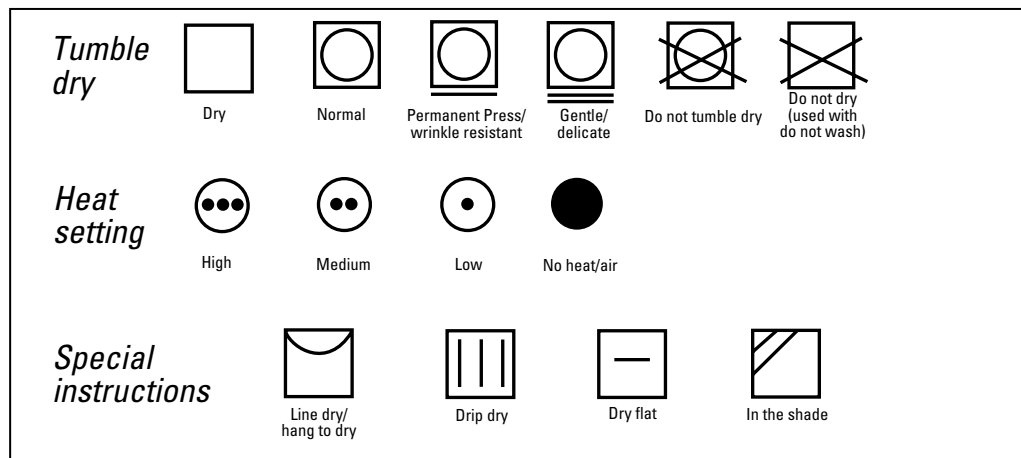

Bleach Labels

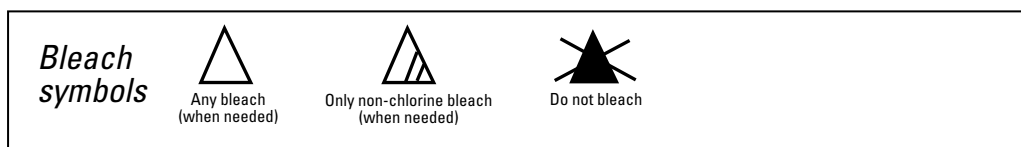

Proper Use of Detergent

Using too much detergent is a common cause of laundry problems. Today's detergents are formulated to be effective without highly visible sudsing. Be sure to carefully read and follow manufacturer's recommendations for how much detergent to use in your wash.

You can use less detergent if you have soft water, a smaller load or a lightly soiled load.

NOTE: Use only low-sudsing, high-efficiency detergent such as Tide® HE.

Care and Cleaning of the Washer

Wash Basket: Leave the lid open after washing to allow moisture to evaporate. If you want to clean the basket, use a clean soft cloth dampened with liquid detergent; then rinse. (Do not use harsh or gritty cleaners.)

Fill Hoses: Hoses connecting washer to faucet should be replaced every 5 years.

Exterior: Immediately wipe off any spills. Wipe with damp cloth. Do not touch the surface or the Touch Screen with sharp objects.

Moving and Storage: Ask the service technician to remove water from drain pump and hoses. For more information, visit www.GEAppliances.com or call **800.GE.CARES** (800.432.2737). Do not store the washer where it will be exposed to the weather.

Long Vacations: Be sure water supply is shut off at faucets. Drain all water from hoses if weather will be below freezing.

Dispenser Drawers: Detergent and fabric softener may build up in the dispenser drawer. Residue should be removed once or twice a month.

- 1 Remove the drawer by pulling it straight out until it stops. Lift up on the front of the drawer and pull it out.

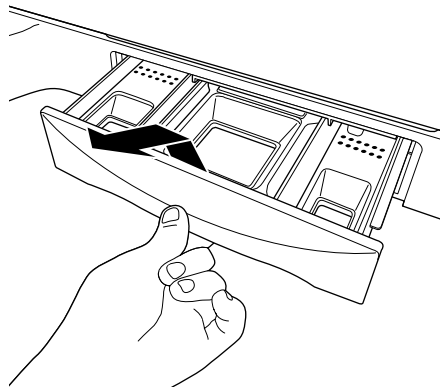

- 2 Remove the inserts from the 3 compartments; rinse the inserts and the drawer with warm water to remove traces of accumulated laundry products.

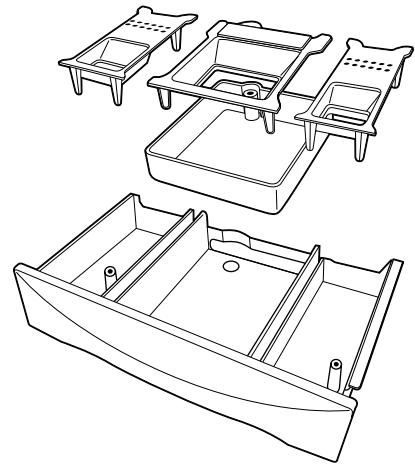

- 3 To clean the drawer opening, use a small, non-metal brush to clean the recess. Remove all residue from the upper and lower parts of the recess.

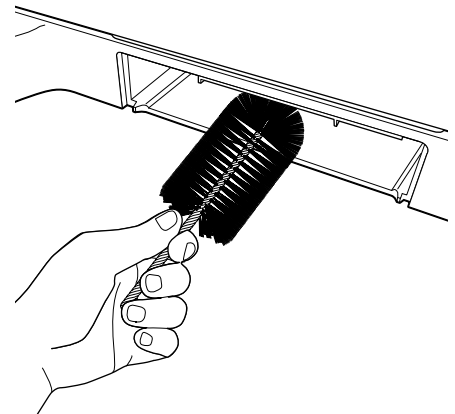

- 4 Return the inserts to the proper compartments and replace the drawer.

Installation Instructions

Washer

WPGT9350

Questions? Call 800.GE.CARES (800.432.2737) or visit our Web site at: www.GEAppliances.com

BEFORE YOU BEGIN

Read these instructions completely and carefully.

- **IMPORTANT** – Save these instructions for local electrical inspector's use.
- **IMPORTANT** – Observe all governing codes and ordinances.
- **Note to Installer** – Be sure to leave these instructions with the Consumer.
- **Note to Consumer** – Keep these instructions for future reference.
- **Skill level** – Installation of this appliance requires basic mechanical skills.
- Proper installation is the responsibility of the installer.
- Product failure due to improper installation is not covered under the Warranty.

PLUMBING REQUIREMENTS

WATER PRESSURE – Must be 10 psi minimum to 120 psi maximum.

WATER TEMPERATURE – Household water heater should be set to deliver water at 120° to 150°F (50° to 66°C) TO THE WASHER.

SHUTOFF VALVES – Both hot and cold shutoff valves (faucets) should be supplied.

DRAIN – Water may be drained into standpipe or set tub. Discharge height **MUST NOT BE LESS THAN 30 INCHES** and no more than 8 feet above the base of the washer. Standpipe must be 1½ inches minimum inside diameter and must be open to atmosphere.

FOR YOUR SAFETY:

ELECTRICAL REQUIREMENTS

⚠ CAUTION – For personal safety, do not use an extension cord or adapter plug with this appliance. Do not, under any circumstances, cut or remove the third grounding prong from the power cord. Follow national electrical codes and ordinances. This appliance must be supplied with the voltage and frequency indicated on the rating plate (located on the rear cover of the backsplash), and connected to an individual, properly grounded branch circuit, protected by a 15- or 20-amp circuit breaker or time-delay fuse. If the electric supply provided does not meet the above requirements, call a licensed electrician.

GROUNDING INSTRUCTIONS

This appliance must be grounded. In the event of malfunction or breakdown, grounding will reduce the risk of electric shock by providing a path of least resistance for electric current. This appliance is equipped with a cord having an equipment-grounding conductor and a grounding plug. The plug must be plugged into an appropriate outlet that is properly installed and grounded in accordance with all local codes and ordinances.

⚠ WARNING – Improper connection of the equipment-grounding conductor can result in a risk of electric shock. Check with a qualified electrician or serviceman if you are in doubt as to whether the appliance is properly grounded. Do not modify the plug provided with the appliance—if it will not fit the outlet, have a proper outlet installed by a qualified electrician.

Installation Instructions

WASHER LOCATION

The washer must be installed on firm flooring to minimize vibration during the spin cycle.

Concrete flooring is best, but a wood floor is sufficient, provided floor support meets FHA standards. The washer should not be installed on rugs or exposed to weather.

Minimum clearance between washer and adjacent walls or other surfaces:

- 0" either side
- 2" front
- 3" rear

Minimum vertical space from floor to overhead shelves, cabinets, ceilings, etc., is 52".

REQUIREMENTS FOR ALCOVE OR CLOSET INSTALLATION

Your washer is approved for installation in an alcove or closet, as stated on a label on the back of the machine.

Minimum clearance between washer and adjacent walls or other surfaces:

- 0" either side
- 2" front
- 3" rear

Minimum vertical space from floor to overhead shelves, cabinets, ceilings, etc., is 52".

Closet doors must be louvered or otherwise ventilated and have at least 60 square inches of open area for washer only, or if the closet contains both a washer and a dryer, door must contain at least 120 square inches of open area equally distributed. Air openings are required to be unobstructed when a door is installed. A louvered door with equivalent air openings for the full length of the door is acceptable.

NOTE: The clearances stated on this label are minimums. Consideration must be given to providing adequate clearances for installing and servicing.

WASHER DIMENSIONS

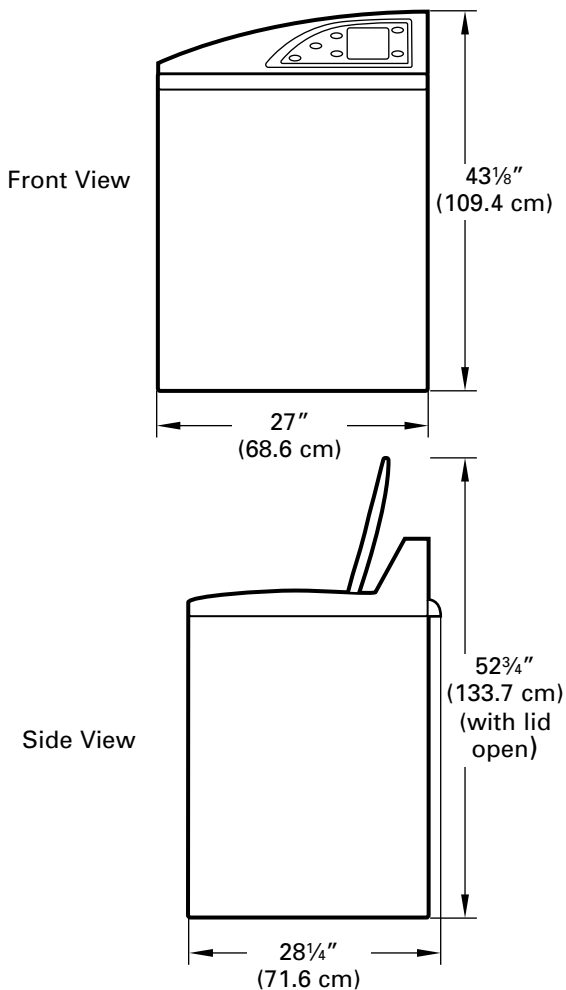

Installation Instructions

PARTS INCLUDED

- Water Hoses (2)

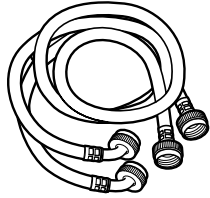

- Cable Tie



1 UNPACK THE WASHER (CONT.)

Remove the Styrofoam block containing the Owner's Manual, parts, water hoses and laundry product samples.

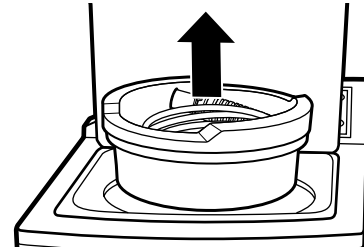

Remove the power cord from the back of the washer.

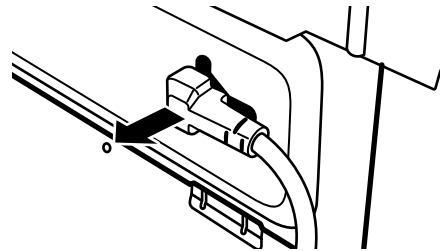

TOOLS YOU WILL NEED

- Adjustable Pliers

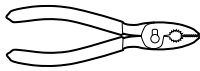

- Carpenter's Level



1 UNPACK THE WASHER

After the washer is in the home, remove the carton and Styrofoam shipping base from the washer.

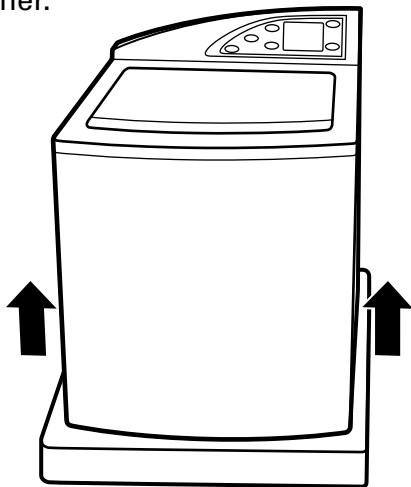

SWITCH WASHER AND DRYER BACKSPLASHES (OPTIONAL)

If necessary, switch the backsplashes for the washer and dryer (see "Switching the Washer and Dryer Backsplashes").

Installation Instructions

2 ATTACH WATER HOSES TO WASHER

Thread the hot water hose onto the washer hot water connection (ORANGE) and the cold water hose onto the cold water connection (BLUE). Hand tighten; then make an additional 1/8 turn with pliers.

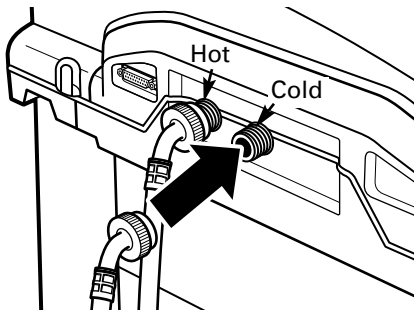

3 MOVE WASHER CLOSE TO HOUSE UTILITIES

Move the washer as close to the final location as possible, leaving enough room to make water, drain and electrical connections to the home.

The minimum required rear clearance is 3".

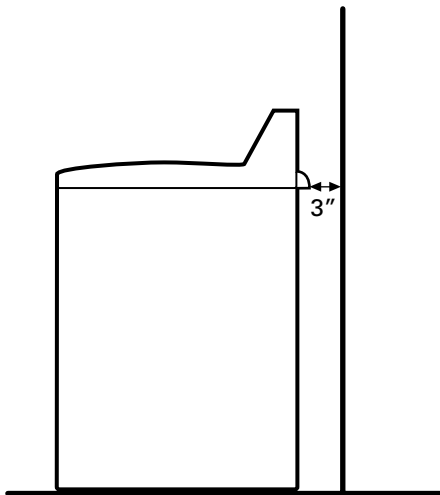

4 CONNECT WATER HOSES TO HOUSE UTILITIES

Connect the water hoses to the HOT and COLD water valves of your home. Hand tighten, plus make an additional 1/4 turn with pliers.

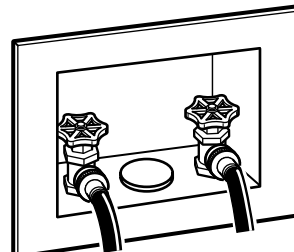

5 ATTACH DRAIN HOSE TO HOUSE DRAIN

Firmly insert the free end of the drain hose into the drain opening of your home. Make sure the soft rubber end is completely inside the drain opening.

- If the water valves and drain are built into the wall, fasten the drain hose to one of the water hoses with the cable tie (ribbed side on inside).
- If your drain is a standpipe, fasten the drain hose to the standpipe with the cable tie provided.

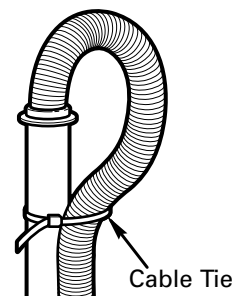
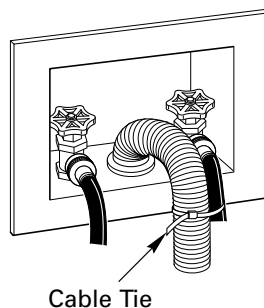

Installation Instructions

6 SET REAR LEGS

Remove the level and tilt the washer forward (pivot on front legs) about 4 to 6 inches and gently lower the rear legs back onto the floor. This action will set rear leg adjustments to correspond to front settings.

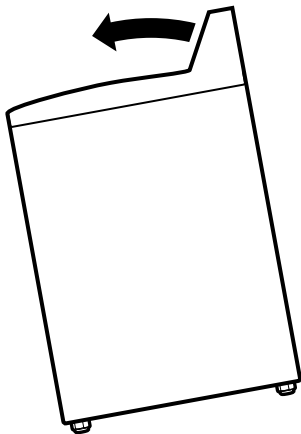

8 ATTACH SERIAL CABLE FOR WASHER/DRYER COMMUNICATION (if desired)

Attach the serial cable shipped with the dryer for washer/dryer communication to the serial port on the back of the washer.

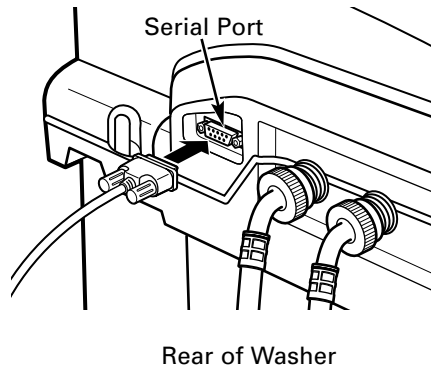

7 LEVEL THE WASHER

Move the washer into final position.

- To check if the washer is level side to side, open the lid and place a level at the back of the opening above the dispenser drawer.
- To check if the washer is level front to back, place a level at the side of the washer on the edge where the cabinet side meets the top cover.

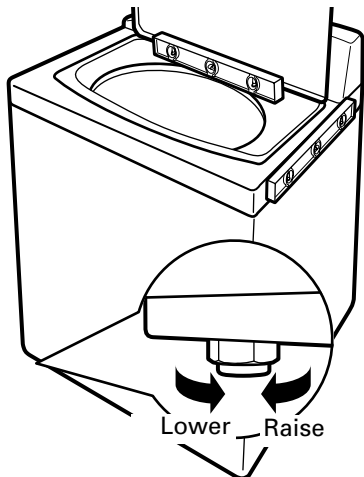

If the washer is not level, adjust the front leveling legs. Turn clockwise to raise, counterclockwise to lower.

Installation Instructions

9 PLUG WASHER IN

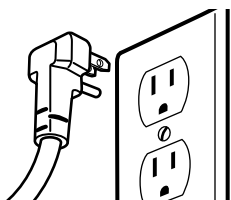

10 WASHER STARTUP

Press the POWER button.

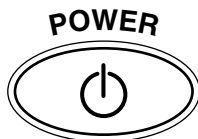

NOTE: If the washer has been exposed to temperatures below freezing for an extended period of time, allow it to warm up before pressing **POWER**. Otherwise, the display will not come on.

The washer is now ready for use.

SERVICING

⚠ WARNING – Label all wires prior to disconnection when servicing controls. Wiring errors can cause improper and dangerous operation after servicing/installation.

For replacement parts and other information, refer to the Owner's Manual for servicing phone numbers.

Installation Instructions

SWITCHING THE WASHER AND DRYER BACKSPLASHES (not required for most installations)

When viewed from the front, the washer is shipped for installation on the left and the dryer is shipped for installation on the right. If your hose utility connections are arranged so that the units must be installed with the washer on the right and the dryer on the left, you can switch the backsplashes of the washer and dryer in order to maintain the proper curved appearance.

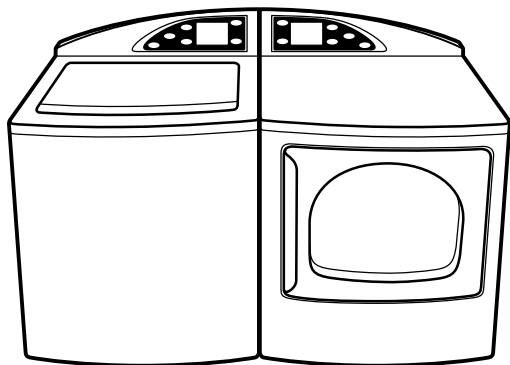

1 REMOVE WASHER BACKSPLASH

Place a towel over the lid of the washer to prevent scratches to the surface. Remove the two outer screws from the rear of the washer backsplash. Rotate backsplash forward and lift off.

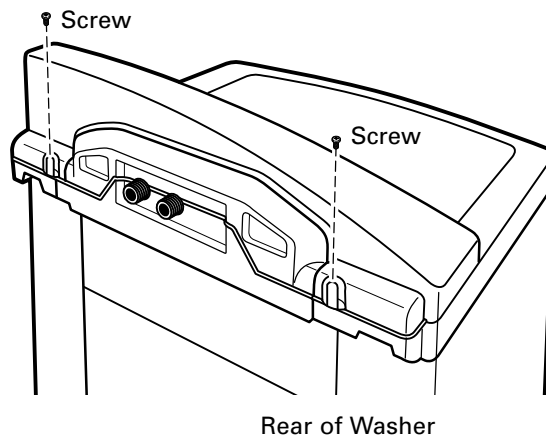

TOOLS YOU WILL NEED



#2 Phillips screwdriver

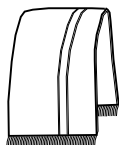

Towel (2)

⚠ WARNING!

Make sure the washer and dryer are unplugged.

2 REMOVE BACKSPLASH REAR COVER

Remove the two screws holding the washer backsplash to the rear cover. Pull off the rear cover.

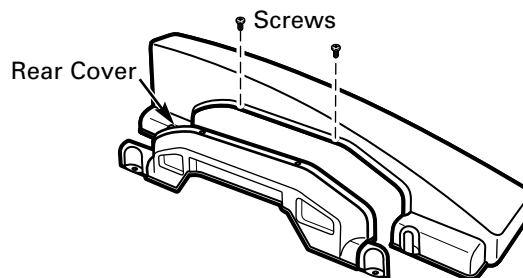

Installation Instructions

3 DISCONNECT WASHER CONTROL BOARD

Disconnect the ribbon at the right of the control board by pulling the connector at the end of the ribbon off the metal pins on the control board.

NOTE: Do not disconnect any other wires from the control board.

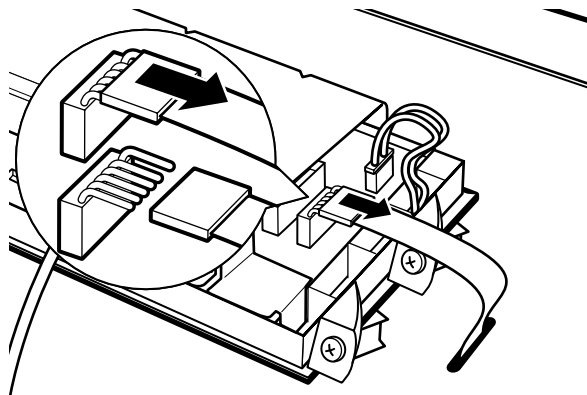

Rear of Washer

4 REMOVE CONTROL BOARD FROM WASHER BACKSPLASH

Remove the four screws holding the control board to the backsplash. Remove the control board and set it aside.

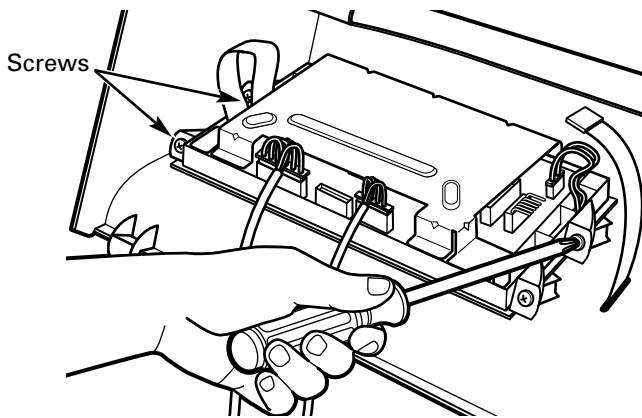

5 REMOVE DRYER BACKSPLASH

Place a towel over the top surface of the dryer to prevent scratches to the surface.

Remove the four screws from the rear of the dryer backsplash. Rotate backsplash forward and lift off.

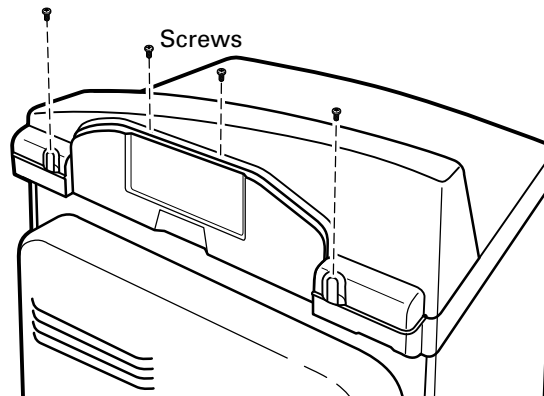

Rear of Dryer

6 DISCONNECT DRYER CONTROL BOARD

Disconnect the ribbon at the right of the control board by pulling the connector at the end of the ribbon off the metal pins on the control board.

NOTE: Do not disconnect any other wires from the control board.

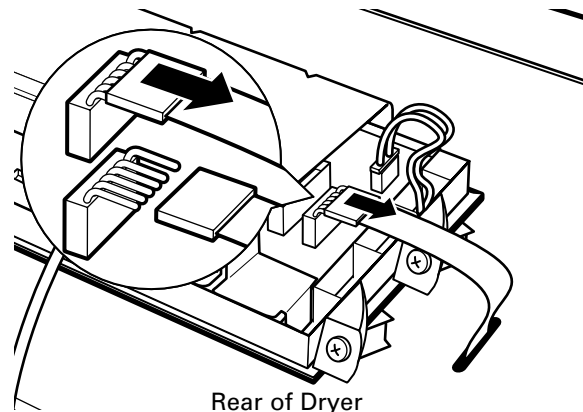

Rear of Dryer

Installation Instructions

7 REMOVE CONTROL BOARD FROM DRYER BACKSPLASH

Remove the four screws holding the control board to the backsplash. Remove the control board and set it aside.

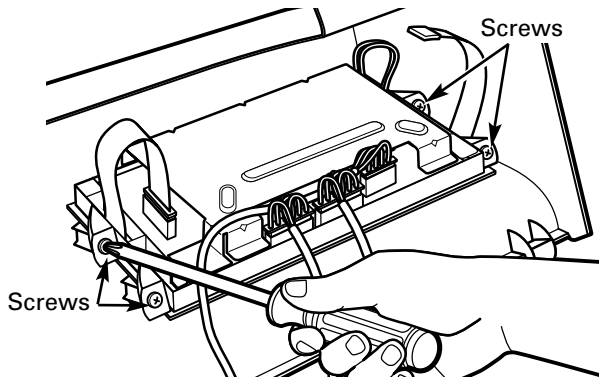

8 SWITCH BACKSPLASHES

Place the backsplash from the dryer on top of the washer and place the backsplash from the washer on top of the dryer.

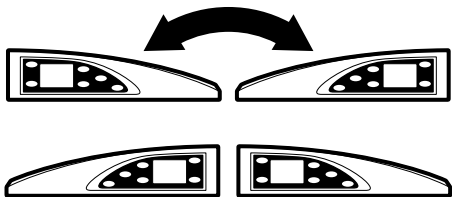

9 ATTACH DRYER CONTROL BOARD TO NEW BACKSPLASH

Attach the control board to the new backsplash by replacing the four screws removed from the control board earlier.

The control board will now be on the opposite side of the dryer backsplash.

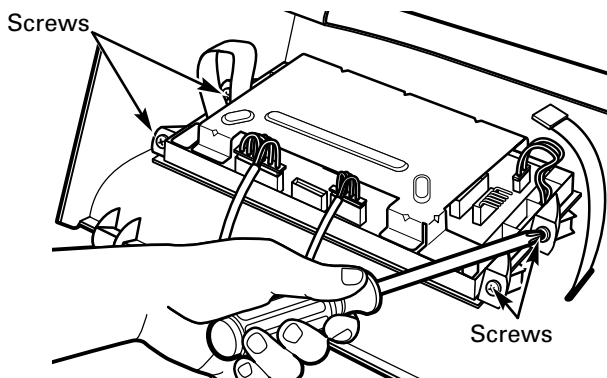

10 RECONNECT DRYER CONTROL BOARD

Connect the dryer control board to the new backsplash by sliding the ribbon connector on the new backsplash onto the metal pins on the control board and pushing in. Make sure the ribbon is not twisted before inserting the connector.

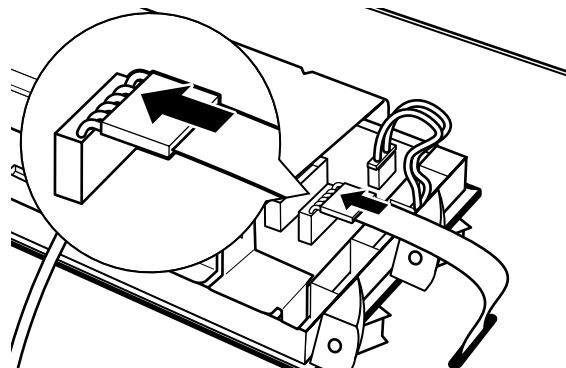

Place the ribbon and the wire from the rear cover under the strain relief on the new backsplash.

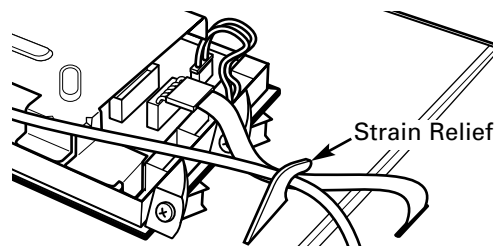

11 ATTACH DRYER BACKSPLASH

Insert the tabs on the bottom front of the backsplash into the slots on the dryer and rotate the backsplash into place. Secure the new backsplash to the dryer using the four screws removed earlier.

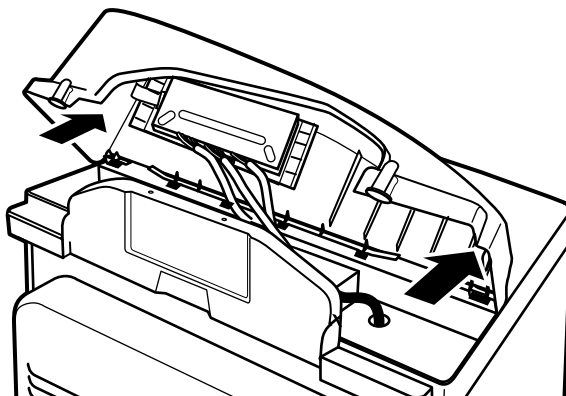

Installation Instructions

12 ATTACH WASHER CONTROL BOARD TO NEW BACKSPLASH

Replace the four screws removed from the control board earlier.

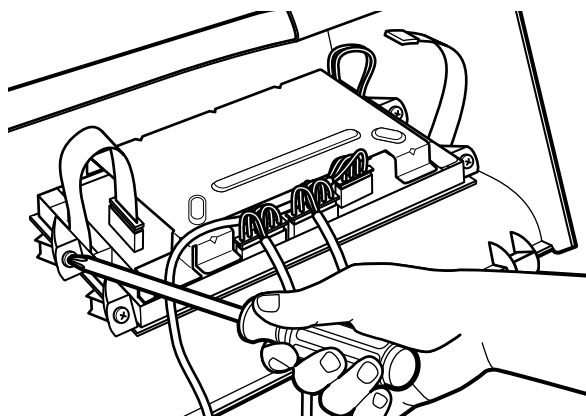

The control board will now be on the opposite side of the washer backsplash.

13 RECONNECT WASHER CONTROL BOARD

Connect the washer control board to the new backsplash by sliding the ribbon connector on the new backsplash onto the metal pins on the control board and pushing in. Make sure the ribbon is not twisted before inserting the connector.

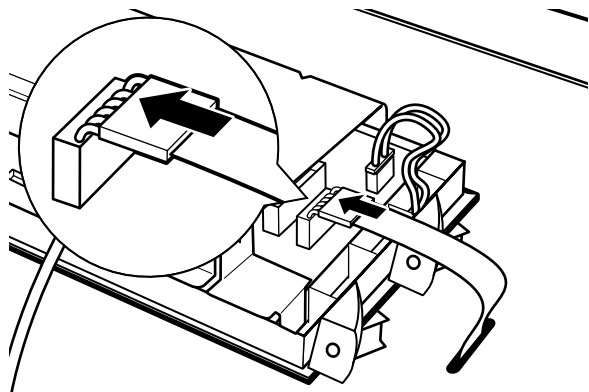

14 ATTACH WASHER BACKSPLASH

Using the two small screws removed earlier, screw the new washer backsplash onto the rear cover.

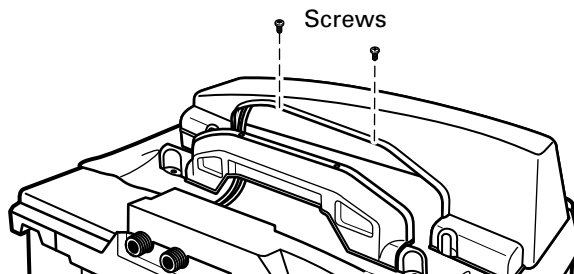

Place the gray wire from the serial port under the strain relief on the new backsplash.

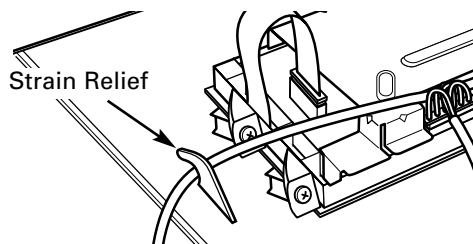

Insert the tabs on the bottom front of the backsplash into the slots on the washer and rotate the backsplash into place. Press the rear of the backsplash down to make sure it fits properly.

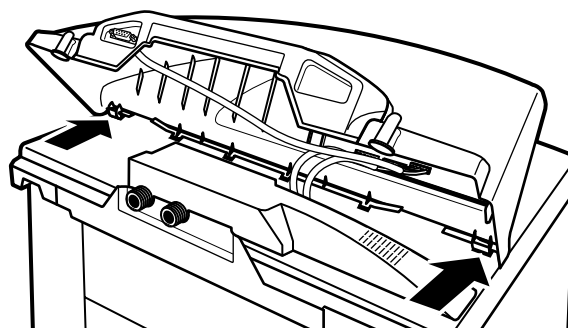

Secure the new backsplash to the washer using the two long screws removed earlier.

15 RECONNECT POWER SUPPLY TO WASHER AND DRYER

- Plug the washer and dryer back in.
- Press the **POWER** buttons on both the washer and dryer to make sure both control boards are properly connected.

For a complete list of solutions to common washer problems, use the Troubleshooting Tips feature located by pressing the **HELP button while on the washer Home Screen (see *Using the Troubleshooter*).**

If your washer will not operate, check the Problem Solver below:

| Problem | Possible Cause | What To Do |
|-----------------------------|--|--|
| <i>Washer won't operate</i> | Control panel is asleep | <ul style="list-style-type: none"> This is normal. Press POWER, the Touch Screen or any button to activate the control panel. |
| | Washer is unplugged | <ul style="list-style-type: none"> Make sure cord is plugged securely into a working outlet. |
| | Water supply is turned off | <ul style="list-style-type: none"> Turn both hot and cold faucets fully on. |
| | Controls are not set properly | <ul style="list-style-type: none"> Make sure the cycle was set correctly, close the lid and press START. |
| | Lid is open—safety feature. Prevents the washer from filling and operating when lid is up. | <ul style="list-style-type: none"> Close lid and reset cycle, to the beginning if necessary. |
| | Circuit breaker/fuse is tripped/blown | <ul style="list-style-type: none"> Check house circuit breakers/fuses. Replace fuses or reset breaker. Washer should have separate outlet. |
| | Electronics need to be reset | <ul style="list-style-type: none"> Unplug washer, wait 2 minutes, plug back in and press POWER. |
| | START was not pressed after a cycle was set | <ul style="list-style-type: none"> Press START. |
| | Extremely low water pressure | <ul style="list-style-type: none"> Press START again. |
| | Washer is too cold | <ul style="list-style-type: none"> If the washer has been exposed to temperatures below freezing for an extended period of time, allow it to warm up before pressing POWER. Otherwise, the display will not come on. |

The following are normal sounds you may hear:

| Sound | Description |
|---|--|
| <i>Repeated starting and stopping</i> | <ul style="list-style-type: none"> • The HydroWash™ action spins the wash basket in one direction, then pauses and spins in the opposite direction to clean your items. |
| <i>Sound of water being added after the washer has already been operating</i> | <ul style="list-style-type: none"> • The washer adapts to the load size and type to add more water to the cycle as needed. • The wash load may be unbalanced. If the washer senses that the load is unbalanced, it will stop and refill to redistribute the load. • The washer may be diluting laundry additives to add to the wash load. |
| <i>Clicking sound during the wash cycle</i> | <ul style="list-style-type: none"> • The washer will make a series of clicking noises as it changes the cleaning mode. |
| <i>High-pitched noise during the spin cycle</i> | <ul style="list-style-type: none"> • The wash basket spins faster to remove moisture from the load. |
| <i>Water flushing sound</i> | <ul style="list-style-type: none"> • The washer is diluting laundry additives to add to the wash load. Wash Boost additives are dispensed during presoak. Detergent is dispensed at the beginning of the wash cycle. Bleach is dispensed during the main wash. Fabric softener is dispensed during the final rinse. |
| <i>Humming noise during draining</i> | <ul style="list-style-type: none"> • The pump is operating to remove water from the basket. |
| <i>Pinging noise during the spin or rinse cycle</i> | <ul style="list-style-type: none"> • The washer has special rinse features to remove detergent residue from the load after the main wash cycle. |
| <i>Water sloshing sound when washer is turned off and tub is rotated</i> | <ul style="list-style-type: none"> • A liquid in the balance ring around the wash basket helps the basket spin smoothly. |

Washer Warranty

www.GEAppliances.com

All warranty service provided by our Factory Service Centers or an authorized Customer Care® technician. To schedule service, on-line, 24 hours a day, visit us at www.GEAppliances.com or call 800.GE.CARES (800.432.2737).

*Staple your receipt here.
Proof of the original purchase date is needed to obtain service under the warranty.*

| For The Period Of: | We Will Replace: |
|--|---|
| One Year <i>From the date of the original purchase</i> | <i>Any part</i> of the washer which fails due to a defect in materials or workmanship. During this full one-year warranty , GE will also provide, free of charge , all labor and related service costs to replace the defective part. |
| Second Year <i>From the date of the original purchase</i> | <i>Any part</i> of the washer which fails due to a defect in materials or workmanship. During this additional one-year limited warranty , you will be responsible for any labor or related service costs. |
| Third through Fifth Year <i>From the date of the original purchase</i> | <i>The suspension rod and spring assembly, and main electronic control board</i> if any of these parts should fail due to a defect in materials or workmanship. GE will also replace the washer lid or cover if they should rust under operating conditions. During this additional three-year limited warranty , you will be responsible for any labor or related service costs. |
| Third through Tenth Year <i>From the date of the original purchase</i> | <i>The direct drive motor and outer washer tub</i> if any of these parts should fail due to a defect in materials or workmanship. During this additional eight-year limited warranty , you will be responsible for any labor or related service costs. |
| Lifetime of Product <i>From the date of the original purchase</i> | <i>The washer basket</i> if it should fail due to a defect in materials or workmanship. During this product lifetime limited warranty , you will be responsible for any labor or related service costs. |

What Is Not Covered:

- | | |
|--|---|
| <ul style="list-style-type: none"> ■ Service trips to your home to teach you how to use the product. ■ Improper installation, delivery or maintenance. ■ Failure of the product if it is abused, misused, or used for other than the intended purpose or used commercially. | <ul style="list-style-type: none"> ■ Replacement of house fuses or resetting of circuit breakers. ■ Damage to the product caused by accident, fire, floods or acts of God. ■ Incidental or consequential damage caused by possible defects with this appliance. ■ Damage caused after delivery. |
|--|---|

This warranty is extended to the original purchaser and any succeeding owner for products purchased for home use within the USA. In Alaska, the warranty excludes the cost of shipping or service calls to your home. Proof of the original purchase date is needed to obtain service under the warranty.

Some states do not allow the exclusion or limitation of incidental or consequential damages. This warranty gives you specific legal rights, and you may also have other rights which vary from state to state. To know what your legal rights are, consult your local or state consumer affairs office or your state's Attorney General.

Warrantor: General Electric Company. Louisville, KY 40225

GE Appliances Web site

www.GEAppliances.com

Have a question or need assistance with your appliance? Try the GE Appliances Web site 24 hours a day, any day of the year! For greater convenience and faster service, you can now download Owner's Manuals, order parts, catalogs, or even schedule service on-line. You can also "Ask Our Team of Experts™" your questions, and so much more...

Schedule Service

www.GEAppliances.com

Expert GE repair service is only one step away from your door. Get on-line and schedule your service at your convenience 24 hours any day of the year! Or call 800.GE.CARES (800.432.2737) during normal business hours.

Real Life Design Studio

www.GEAppliances.com

GE supports the Universal Design concept—products, services, and environments that can be used by people of all ages, sizes, and capabilities. We recognize the need to design for a wide range of physical and mental abilities and impairments. For details of GE's Universal Design applications, including kitchen design ideas for people with disabilities, check out our Web site today. For the hearing impaired, please call 800.TDD.GEAC (800.833.4322).

Extended Warranties

www.GEAppliances.com

Purchase a GE extended warranty and learn about special discounts that are available while your warranty is still in effect. You can purchase it on-line anytime or call 800.626.2224 during normal business hours. GE Consumer Home Services will still be there after your warranty expires.

Parts and Accessories

www.GEAppliances.com

Individuals qualified to service their own appliances can have parts or accessories sent directly to their homes (VISA, MasterCard, and Discover cards are accepted). Order on-line today, 24 hours every day, or by phone at 800.626.2002 during normal business hours.

Instructions contained in this manual cover procedures to be performed by any user. Other servicing generally should be referred to qualified service personnel. Caution must be exercised, since improper servicing may cause unsafe operation.

Contact Us

www.GEAppliances.com

If you are not satisfied with the service you receive from GE, contact us on our Web site with all the details, including your phone number, or write to: General Manager, Customer Relations
GE Appliances, Appliance Park
Louisville, KY 40225

Register Your Appliance

www.GEAppliances.com

Register your new appliance on-line—at your convenience! Timely product registration will allow for enhanced communication and prompt service under the terms of your warranty, should the need arise. You may also mail in the preprinted registration card included in the packing material.