

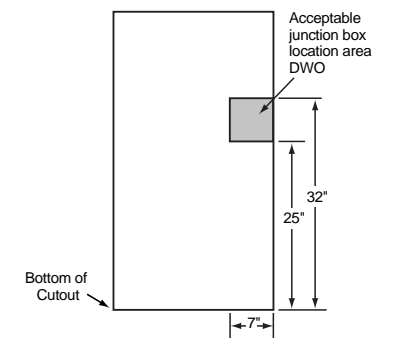

Profile™

JT980SH/WH/CH/BH – GE Profile™ 30" Built-In Double Oven with Trivection™ Technology

Dimensions (in inches)

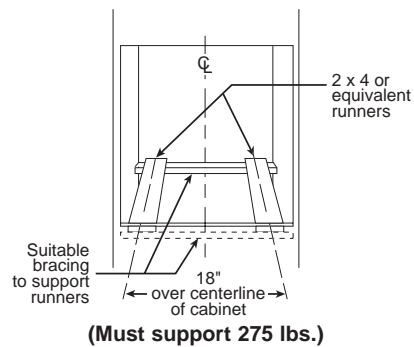
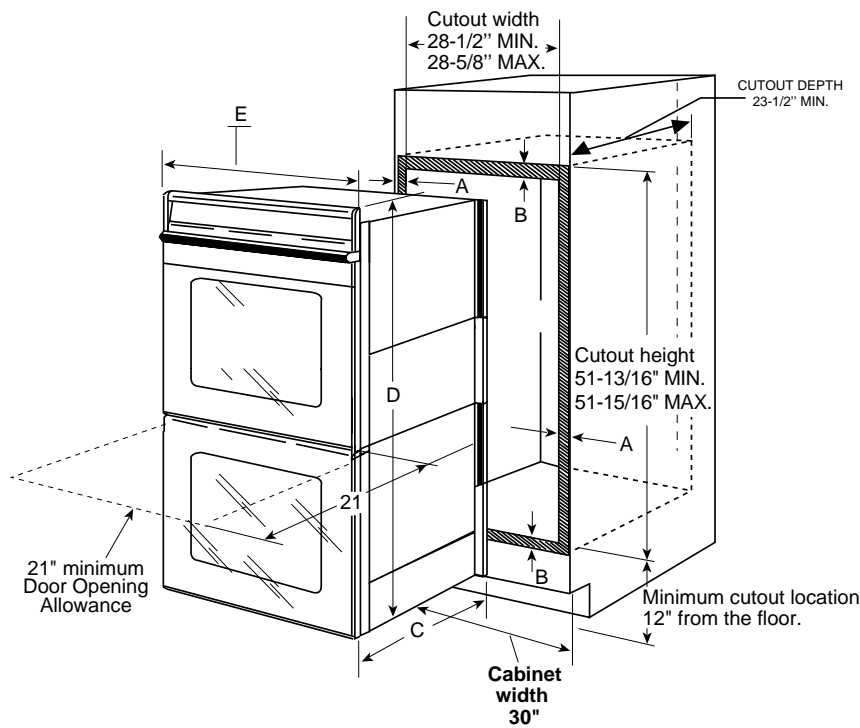

Cabinet	30"
A – Overlap of Oven Over Side Edges of Cutout	11/16" – 3/4"
B – Overlap of Oven at Top and Bottom of Cutout	1"
Oven	
C – Overall Depth	23-1/2"
D – Overall Height	52-7/8"
E – Overall Width	29-3/4"

Note: Cabinets installed adjacent to wall ovens must have an adhesion spec of at least a 194°F temperature rating.

Installation Information: Before installing, consult installation instructions packed with product for current dimensional data.

KW Rating	
240V	8.9
208V	6.7
Breaker Size	
240V	40 Amps
208V	40 Amps

Electric wall ovens are not approved for installation with a plug and receptacle. They must be hard wired in accordance with installation instructions.



For answers to your Monogram®, GE Profile™ or GE® appliance questions, visit our website at GEAppliances.com or call GE Answer Center® service, 800.626.2000.



Profile™

JT980SH/WH/CH/BH – GE Profile™ 30" Built-In Double Oven with Trivection™ Technology

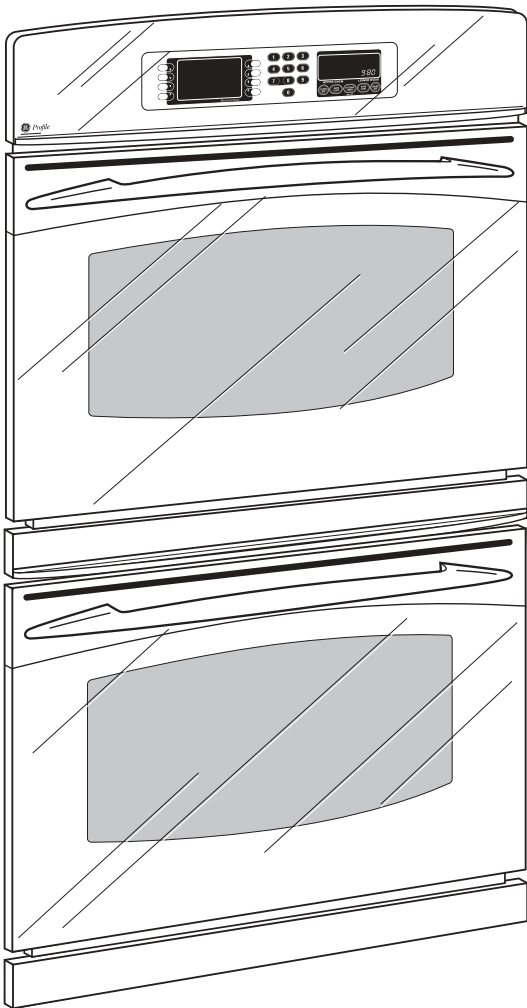

Features and Benefits

- Trivection technology – Combines thermal, convection and microwave energies to produce quality food remarkably fast.
- Speed baking/Speed broiling – Uses Trivection technology to cook food up to five times faster than a traditional oven.
- Convection bake (multi-rack) – Provides ideal convection baking for multiple racks of food, ensuring superb results.
- Convection roast – Provides even cooking and consistent results, roasting meats up to 25% faster than a conventional oven.
- Chef's Guide™ glass touch oven controls – Feature a smooth glass design that is both easy-to-operate and easy-to-clean.
- Self-clean oven – Conveniently cleans cavity without the need for scrubbing.
- Extra-large oven capacity – Provides a large oven interior ideal for cooking more items at once.
- TrueTemp™ system – Delivers even heat distribution and maximum oven control.
- Model JT980SHSS – Stainless steel
- Model JT980WHWW – White on white
- Model JT980CHCC – Bisque on bisque
- Model JT980BHBB – Black on black