

P2S975DEP

GE Profile™ 30" Dual Fuel Slide-In Gas Range

Dimensions and Installation Information (in inches)

Rear filler strip or backguard are available for these ranges

Note: Door handle protrudes 3" from door face. Cabinets and drawers on adjacent 45° and 90° walls should be placed to avoid interference with the handle.

Note: Cabinets installed adjacent to slide-in ranges must have an adhesion spec of at least 194° temperature rating.

Optional Kits for Slide-In Gas Ranges:

(Available at additional cost)

Lower/Side Trim Kits

JXS56BB - Lower Trim Kit (Black)

Accessory Backguards

JXS32BB - Black Accessory Backguard

JXS37BB - Black Glass Accessory Backguard

Rear Filler Strip

WB07T10680 - Black Filler Strip Assembly

Installation Information: Before installing, consult installation instructions packed with product for current dimensional data.

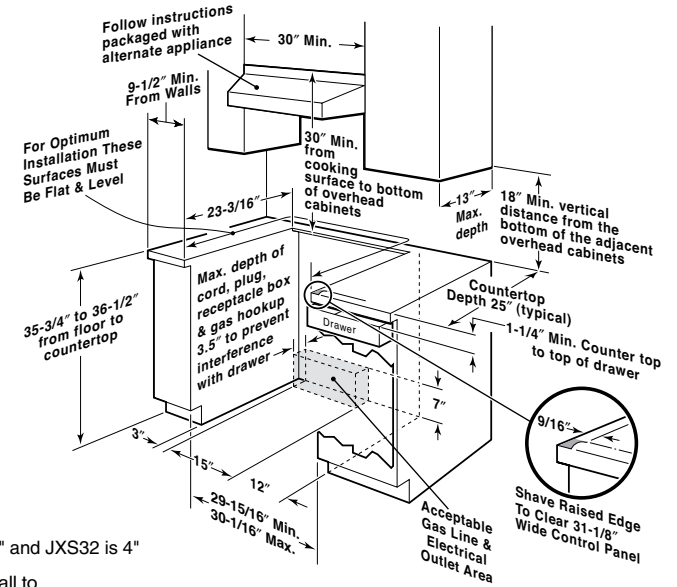
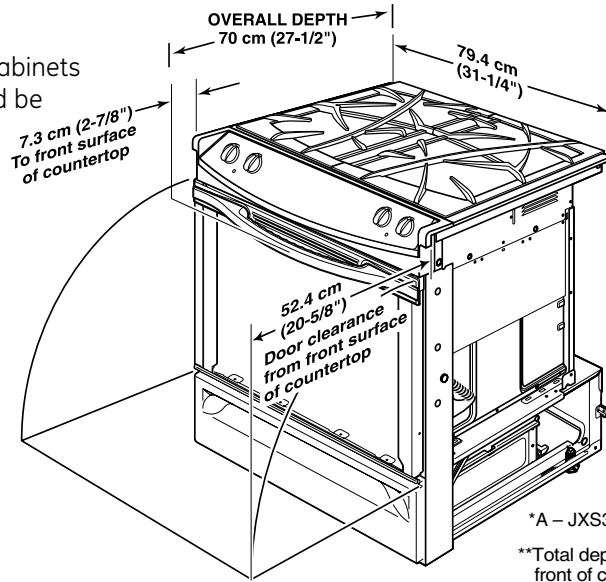

*A - JXS37 is 5-1/4" and JXS32 is 4"

**Total depth from wall to front of closed oven door including handle is 30-1/2."

Counter Cutout Dimensions (in inches)

If you are NOT using the Filler strip or Backguard:

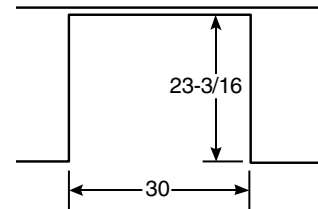

If you are using the Filler strip or Backguard:

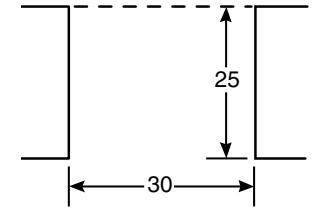

For answers to your Monogram®, GE Profile™ or GE® appliance questions, visit our website at ge.com or call GE Answer Center® service, 800.626.2000.



All GE ranges are equipped with an Anti-Tip device. The installation of this device is an important, required step in the installation of the range.



P2S975DEP

GE Profile™ 30" Dual Fuel Slide-In Gas Range

Features and Benefits

- Dual-fuel Range - Combines responsive gas, sealed burners with a consistent electric oven to maximize performance
- Deep-recessed Cooktop - Deep recessed cooktop keeps spills, and everything else, contained in one area that's easy to wipe clean
- Convection Bake (Multi-Rack) - Provides ideal convection baking for multiple racks of food, ensuring superb results
- PreciseAir™ Convection System - A reversing fan circulates heat and air for evenly browned and baked foods
- Convection Bake - This setting is optimal for baking casseroles or lasagnas, yeast breads, pies and pizzas with no need to turn the pan
- Convection Roast - Optimal for larger cuts of meat, this setting rotates the heat around all sides, sealing in the juices, producing rotisserie results at up to 25% faster than a conventional oven
- Self-clean Oven - Self-clean allows you to spare yourself from the trouble and effort it takes to scrub the oven interior. The oven does all the work!
- Self-clean Heavy-duty Oven Racks - Tough, double-coated racks can stay in the oven during the self-clean cycle to eliminate hand cleaning
- 18,000 BTU Stacked Burner - Features a unique two-in-one burner design for 18,000 BTU boiling or gentle 140 degrees simmer
- Glass Touch Controls - Smooth controls are easy to use and add a sophisticated style to the kitchen
- Model P2S975DEPBB - Black

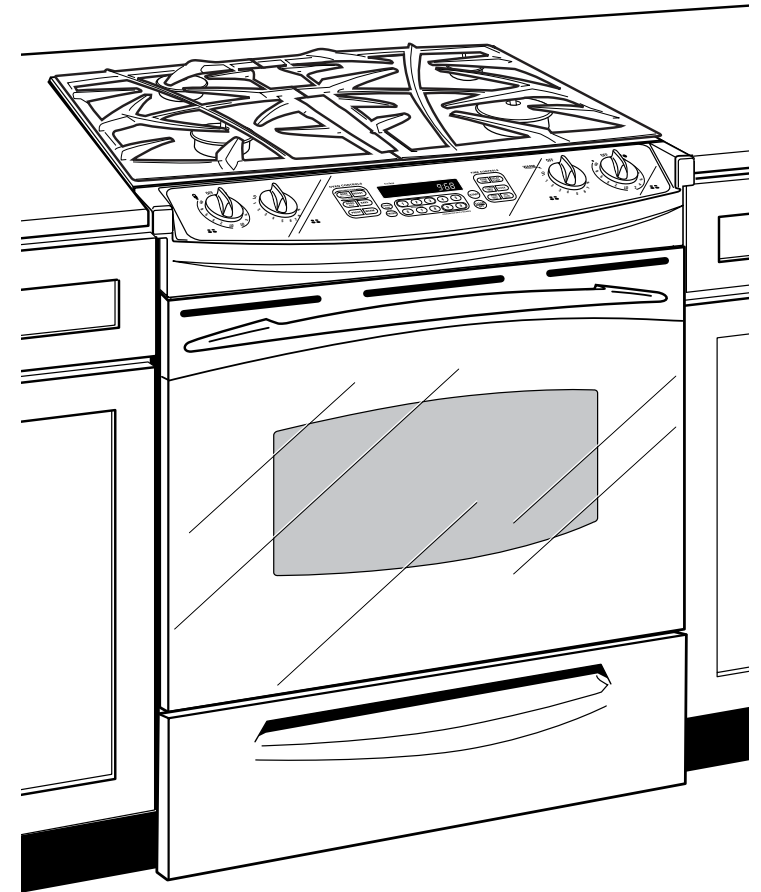

imagination at work