

# MODEL P195ES52SB POWER PACK

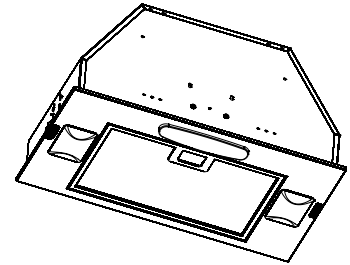

**ENERGY STAR® efficiency for custom applications provides the ventilation and lighting you need in one integrated package.**

**FEATURES**

- 3-speed control
- Centrifugal blower, 290 CFM, 5.0 Sones
- 6" round duct connector/backdraft damper
- Enclosed light
- Two 13Watt, G24Q-1 compact fluorescent lamps (included)
- One piece washable aluminum mesh filter
- 430 stainless steel finish
- Heat Sentry™ automatically turns blower to high speed when excess cooking heat is detected
- Fully enclosed bottom
- Power supply cord included
- One Year Limited Warranty
- For indoor use only

**OPTIONS**

- Protect cabinet with Model L5230 Stainless Steel Liner
- Recirculation filter Model FILTEREB40

**SPECIFICATIONS**

VOLTS	HZ	AMPS	CFM		SONES		DUCT
			MAX.	NORM.	MAX.	NORM.	
120	60	2.8	290	120	5.0	0.5	6" round



HVI-2100 CERTIFIED RATINGS comply with new testing technologies and procedures prescribed by the Home Ventilating Institute, for off-the-shelf products, as they are available to consumers. Product performance is rated at 0.1 in. static pressure, based on tests conducted in a state-of-the-art test laboratory. Sones are a measure of humanly-perceived loudness, based on laboratory measurements.

**TYPICAL SPECIFICATION**

Power Pack shall be Best Model P195ES52SB.  
 Power Pack shall have a 3-speed fan switch and separate light switch.  
 Fan must be ducted and use a washable aluminum mesh filter.  
 Unit shall have a 430 stainless steel finish.  
 Air delivery to be at least 290 CFM and sound levels not greater than 5.0 Sones.  
 Unit shall be UL and cUL listed.  
 Air and sound ratings to be certified by HVI.  
 Unit shall be ENERGY STAR® certified.

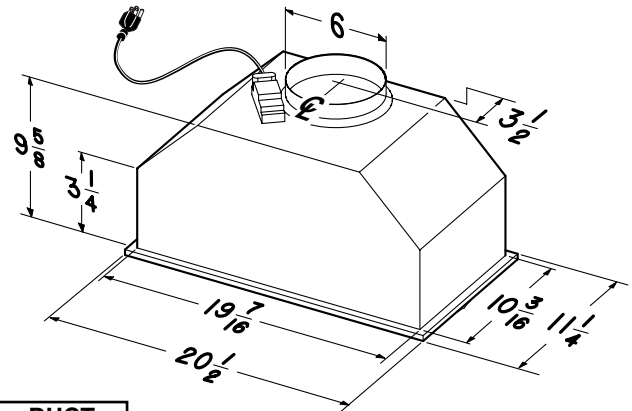

BEST® Hartford, Wisconsin www.BestRangeHoods.com 800-558-1711

REFERENCE	QTY.	REMARKS	Project
			Location
			Architect
			Engineer
			Contractor
			Submitted by <span style="float: right;">Date</span>