

Job Name:

System Reference:

Date:

Indoor Unit:
MSZ-GL09NA

Outdoor Unit:
 MUZ-GL09NA-U1
 MUZ-GL09NA-U2
 MUZ-GL09NA-U8

Wireless Remote Controller



GENERAL FEATURES

- Slim wall-mounted indoor units provide zone comfort control
- The outdoor unit powers the indoor unit, and should a power outage occur, the system is automatically restarted when power returns
- INVERTER-driven compressor and LEV provide high efficiency and comfort while using only the energy needed to maintain maximum performance
- Multiple fan speed options: Quiet, Low, Medium, High, Super-high, Auto
- Multiple control options available:
 - Hand-held Remote Controller (provided with unit)
 - kumo cloud[®] smart device app for remote access
 - Third-party interface options
 - Wired or wireless controllers
- Quiet operation
- Smart Set: recalls a preferred preset temperature setting at the touch of a button
- Blue Fin anti-corrosion treatment applied to the outdoor unit heat exchanger for increased coil protection and longer life

SPECIFICATIONS: MSZ-GL09NA & MUZ-GL09NA

Cooling ¹	Maximum Capacity	BTU/H	12,200
	Rated Capacity	BTU/H	9,000
	Minimum Capacity	BTU/H	3,600
	Maximum Power Input	W	1,050
	Rated Power Input	W	585
	Moisture Removal	Pints/h	1.5
	Sensible Heat Factor		0.82
	Power Factor	%	-U1/2: 86 / 86 -U8: 92 / 92
Heating at 47°F ²	Maximum Capacity	BTU/H	-U1/2: 15,900 -U8: 14,100
	Rated Capacity	BTU/H	10,900
	Minimum Capacity	BTU/H	4,500
	Maximum Power Input	W	-U1/2: 1,250 -U8: 1,070
	Rated Power Input	W	720
	Power Factor	%	-U1/2: 90 / 90 -U8: 95 / 95
Heating at 17°F ³	Maximum Capacity	BTU/H	-U1/2: 10,900 -U8: 9,400
	Rated Capacity	BTU/H	-U1/2: 6,700 -U8: 7,000
	Maximum Power Input	W	-U1/2: 1,060 -U8: 790
	Rated Power Input	W	630
Heating at 5°F ⁴	Maximum Capacity	BTU/H	8,170
	Maximum Power Input	W	850
Heating at -4°F ⁵	Maximum Capacity	BTU/H	6,860
Efficiency	SEER SEER2		24.6 24.3
	EER ¹ EER2 ¹		15.4 15.4
	HSPF (IV) HSPF2 (IV)		12.8 10.9
	COP at 47°F ²		4.44
	COP at 17°F in Maximum Capacity ³		2.82
	COP at 5°F in Maximum Capacity ⁴		2.82
	ENERGY STAR [®] certified units (ENERGY STAR products are third-party certified by an EPA-recognized Certification Body.)		YES
Electrical	Voltage, Phase, Frequency		208/230V, 1 phase, 60Hz
	Guaranteed Voltage Range	V AC	187 - 253
	Voltage: Indoor - Outdoor, S1-S2	V AC	208 / 230
	Voltage: Indoor - Outdoor, S2-S3	V DC	24
	Short-circuit Current Rating (SCCR)	kA	5
	Recommended Fuse/Breaker Size (Outdoor)	A	15
	Recommended Wire Size (Indoor - Outdoor)	AWG	14
Indoor Unit	MCA	A	1
	MOCP	A	15
	Blower Motor Full Load Amperage	A	0.76
	Blower Motor Output	W	30
	Airflow Rate at Cooling, Dry	CFM	399-321-237-170-145
	Airflow Rate at Cooling, Wet	CFM	364-286-201-134-109
	Airflow Rate at Heating, Dry	CFM	406-321-237-170-145
	Sound Pressure Level (Cooling)	dB(A)	43-37-30-22-19
	Sound Pressure Level (Heating)	dB(A)	43-37-30-22-19
	Drain Pipe Size	In. (mm)	5/8 (15.88)
	Heat Exchanger Type		Plate fin coil
	External Finish Color		Munsell 1.0Y 9.2/0.2
	Unit Dimensions	W: In. (mm)	
D: In. (mm)			9-1/8 (232)
H: In. (mm)			11-5/8 (295)

SPECIFICATIONS: MSZ-GL09NA & MUZ-GL09NA

	Package Dimensions	W: In. (mm)	33-1/2 (850)
		D: In. (mm)	12 (300)
		H: In. (mm)	14 (350)
	Unit Weight	Lbs. (kg)	22 (10)
	Package Weight	Lbs. (kg)	26 (11.5)
Indoor Unit Operating Temperature Range	Cooling Intake Air Temp (Maximum / Minimum)*	°F	90 DB, 73 WB / 67 DB, 57 WB
	Heating Intake Air Temp (Maximum / Minimum)	°F	80 DB / 70 DB
Outdoor Unit	MCA	A	9
	MOCP	A	15
	Fan Motor Full Load Amperage	A	0.5
	Fan Motor Output	W	55
	Airflow Rate	CFM	1,229 / 1,172
	Refrigerant Control		LEV
	Defrost Method		Reverse cycle
	Heat Exchanger Type		Plate fin coil
	Sound Pressure Level, Cooling ¹	dB(A)	48
	Sound Pressure Level, Heating ²	dB(A)	50
	Compressor Type		DC INVERTER-driven
	Compressor Model		-U1: KNB073FRVMC -U2: KNB073FRXMC -U8: SNB092FQANT
	Compressor Rated Load Amps	A	6.7
	Compressor Locked Rotor Amps	A	7.7
	Compressor Oil Type // Charge	oz.	-U1/2: FV50S //9.1 -U8: FY50S //11.8
	External Finish Color		Munsell 3Y 7.8/1/1
	Base Pan Heater		Optional
	Unit Dimensions	W: In. (mm)	31-1/2 (800)
		D: In. (mm)	11-1/4 (285)
		H: In. (mm)	21-5/8 (550)
Package Dimensions	W: In. (mm)	37 (940)	
	D: In. (mm)	14-15/16 (380)	
	H: In. (mm)	24-13/16 (630)	
Unit Weight	Lbs. (kg)	81 (37)	
Package Weight	Lbs. (kg)	88 (40)	
Outdoor Unit Operating Temperature Range	Cooling Air Temp (Maximum / Minimum)*	°F	115 / 14
	Cooling Thermal Lock-out / Re-start Temperatures**	°F	-1 / 3
	Heating Air Temp (Maximum / Minimum)	°F	75 / -4
	Heating Thermal Lock-out / Re-start Temperatures**	°F	-9 / -4
Refrigerant	Type		R410A
	Charge	Lbs, oz	-U1/2: 2, 5 -U8: 2, 9
Piping	Gas Pipe Size O.D. (Flared)	In. (mm)	3/8 (9.52)
	Liquid Pipe Size O.D. (Flared)	In. (mm)	1/4 (6.35)
	Maximum Piping Length	Ft. (m)	65 (20)
	Maximum Height Difference	Ft. (m)	40 (12)
	Maximum Number of Bends		10

Notes

AHRI Rated Conditions (Rated data is determined at a fixed compressor speed)	¹ Cooling (Indoor // Outdoor)	°F	80 DB, 67 WB // 95 DB, 75 WB
	² Heating at 47°F (Indoor // Outdoor)	°F	70 DB, 60 WB // 47 DB, 43 WB
	³ Heating at 17°F (Indoor // Outdoor)	°F	70 DB, 60 WB // 17 DB, 15 WB
Conditions	⁴ Heating at 5°F (Indoor // Outdoor)	°F	70 DB, 60 WB // 5 DB, 4 WB
	⁵ Heating at -4°F (Indoor // Outdoor)	°F	70 DB, 60 WB // -4 DB, -5 WB

*Applications should be restricted to comfort cooling only; equipment cooling applications are not recommended for low ambient temperature conditions.

**System cuts out in heating mode to avoid thermistor error and automatically restarts at these temperatures.

DIMENSIONS: MSZ-GL09NA

Unit: inch

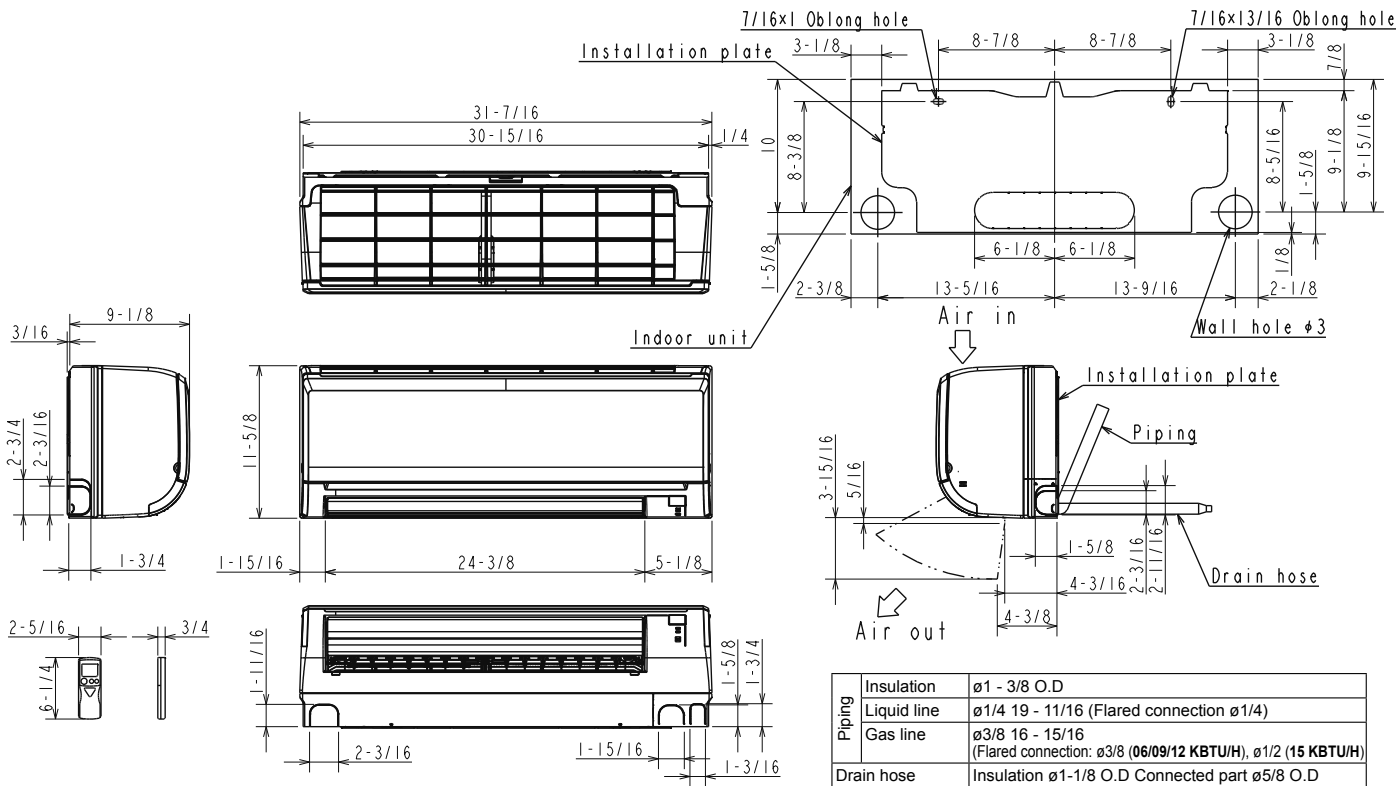

Unit: inch

REQUIRED SPACE

*1 4 in. or more when front and sides of the unit are clear

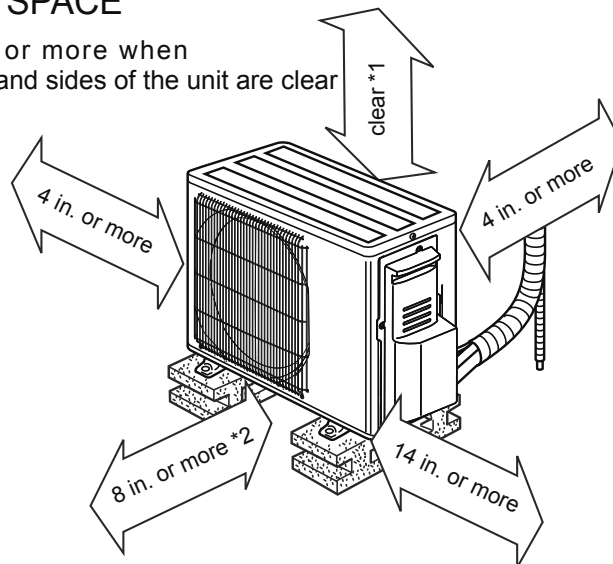

*2 When any 2 sides of left, right and rear of the unit are clear

