





Operating and Installation Instructions

Freezer



To prevent accidents and damage to the appliance, you **must** read all instructions before installing for using the appliance.

Contents

IMPORTANT SAFETY INSTRUCTIONS	4
Guide to the appliance	10
How to save energy	13
Turning the appliance on and off	15
Before first use	15
Operating the appliance	15
Turning the appliance on	15
Turning the appliance off	16
Turning off the appliance in Sabbath mode	16
Turning off for longer periods of time	16
The right temperature	17
Temperature display	17
Sets the temperature	18
Using SuperCool	19
Temperature and door alarm	20
Temperature alarm	20
Door alarm	21
Selecting additional settings	22
Safety lock 	22
Temperature unit (Celsius or Fahrenheit)	23
Acoustic signals 	25
Display brightness 	26
Sabbath mode 	27
Adjusting the interior fittings	29
Freezer drawers on telescopic runners	29
Shelves	29
Freezing and storing food	30
Maximum freezing capacity	30
Freezing food	30
Before placing food in the freezer	30
Placing food in the freezer	30
Defrosting	31
Cooling drinks quickly	32
Using the cool pack	32
Making ice cubes	33
Ice cube maker with integrated ice cube tray	33

Turning the ice cube maker On/Off	34
Making a large amount of ice cubes	34
Changing the size of the ice cubes	35
Setting the water quantity	35
Turning the ice cube maker On/Off with the On/Off button	36
Automatic defrosting	37
Cleaning	38
Rinsing the ice cube maker	39
Cleaning the ice cube tray	40
Setting the cleaning position	40
Interior and accessories	43
Ventilation slits	44
Door seal	44
Frequently asked questions	45
Noises	54
Service / Warranty	56
Warranty	56
Information for dealers/showrooms	57
Demo mode I	57
Caring for the environment	61
Plumbing	62
Information regarding the water connection	62
Electrical connection	65
Installation information	67
Side-by-side	67
Location	67
Climate class	67
Ventilation	68
Ventilation slits	69
Before installation	70
Installation dimensions	71
Adjusting the door hinge	72
Changing the door hinging	73
Installing the appliance	77
Installing the custom door front	85
Contact details	91

IMPORTANT SAFETY INSTRUCTIONS

When using the appliance, follow basic safety precautions, including the following:

Read all instructions before installation and use to prevent accidents and machine damage.

This appliance conforms to current safety requirements. Inappropriate use can, however, lead to personal injury and damage to property.

They contain important notes on installation, safety, use and maintenance. Miele cannot be held liable for non-compliance with these instructions.

Keep these instructions in a safe place and pass them on to any future owner.

Correct use

▶ This appliance is intended for use in domestic households and similar working and residential environments. This appliance is not intended for outdoor use or for use in damp areas exposed to the rain.

▶ This appliance is intended for the cool storage of food and drink. Any other usage is not supported by the manufacturer and could be dangerous. The manufacturer cannot be held liable for damage resulting from incorrect or improper use or operation.

▶ This appliance is not suitable for storing and keeping cool medicines, blood plasma, laboratory preparations or other such materials or products. Incorrect use of the appliance for such purposes can cause deterioration of the items stored. The appliance is not suitable for use in areas where there is a risk of explosion.

Miele cannot be held liable for damage resulting from improper or incorrect use of the appliance.

▶ The appliance can only be used by people with reduced physical, sensory or mental capabilities, or lack of experience and knowledge if they are supervised whilst using it or have been shown how to use it in a safe way and recognize and understand the consequences of incorrect operation.

Safety with children

▶ Children should be supervised in the vicinity of the appliance.

▶ Children ages eight and up may only use the appliance oven without supervision if they have been shown how to use it in a safe manner, and if they are able to recognize and understand the potential risks of improper use.

▶ Children must not clean or service the appliance unless they are under supervision.

IMPORTANT SAFETY INSTRUCTIONS

▶ Children should be supervised when they are near the appliance. This appliance is not a toy! To avoid the risk of injury, do not allow children to play with it or to use the controls. They will not understand the potential dangers posed by it. They should be supervised whenever you are working in the kitchen.

▶ Ensure that any packing material is disposed of safely and kept out of the reach of children. Danger of suffocation!

Technical safety

▶ The coolant system is tested for leaks.

▶ This appliance contains the coolant isobutane (R600a), a natural gas which is environmentally friendly. Although it is flammable, it does not damage the ozone layer and does not increase the greenhouse effect.

The use of this coolant has, however, led to a slight increase in the noise level of the appliance. In addition to the noise of the compressor, you might be able to hear the coolant flowing around the system. This is unavoidable, and does not have any adverse effect on the performance of the appliance.

Care must be taken during the transportation and setting up of the appliance that no parts of the cooling system are damaged. Leaking refrigerant can damage the eyes. In the event of any damage:

- avoid open flames and anything that creates a spark
- disconnect the appliance from the electrical power supply
- air the room in which the appliance is located for several minutes
- contact Miele Technical Service

▶ The more coolant there is in an appliance, the larger the room in which it should be installed. In the event of a leakage, there is the danger of combustible gases building up if the appliance is in a small room. For every 8 g of coolant at least 1 m³ of room space is required. The amount of coolant in the appliance is stated on the data plate inside the appliance.

▶ To avoid the risk of damage to the appliance, make sure that the connection data (fuse rating, frequency and voltage) on the data plate corresponds to the household supply. Check that this is the case before connecting the appliance. Consult a qualified electrician if in any doubt.

▶ Be certain your appliance is properly installed and grounded by a qualified technician. To guarantee the electrical safety of this appliance, continuity must exist between the appliance and an effective grounding system. It is imperative that this basic safety requirement be met. If there is any doubt, have the electrical system of the house checked by a qualified electrician.

IMPORTANT SAFETY INSTRUCTIONS

▶ If the power cord is damaged, it must be replaced by a Miele authorized technician in order to protect the user from harm.

▶ Do not connect the appliance to the electrical supply with a power bar or extension cord. These are a fire hazard and do not guarantee the required safety of the appliance.

▶ Do not use the appliance in areas where there may be moisture or splashing water (e.g., garages, laundry rooms, etc.). Moisture can reach the electrical components and cause a short circuit.

▶ This appliance is not to be used in non-stationary locations, such as ships.

▶ Do not use a damaged appliance. It could be dangerous. Check the appliance for visible signs of damage.

▶ To ensure safe operation, use the appliance only when it is installed.

▶ The appliance must be disconnected from the electrical supply during installation, maintenance and repair work, and installation work on the water connection. The appliance is only completely isolated from the electrical supply when:

- The circuit breakers on the electrical service panel are tripped.
- The screw-type fuses on the electrical service panel have been removed.
- The power cord has been unplugged.
Pull on the plug and not on the cord when removing it from the outlet.

▶ Installation, repair and maintenance work should be performed by a Miele authorized service technician in accordance with national and local safety regulations and the provided installation instructions. Contact Miele's Technical Service Department for examination, repair or adjustment.

▶ The ice cube maker is not intended to be used with a hot water supply line.

▶ Repairs and other work performed by unauthorized persons could be dangerous and may void the warranty.

▶ Defective components should only be replaced by Miele original parts. Only with these parts can the manufacturer guarantee the safety of the appliance.

Proper use

▶ The appliance is designed for use within a certain climate range (ambient temperatures), and should not be used outside this range. The climate range for your appliance is stated on the data plate inside the appliance. Installing it in a room with too low an ambient temperature, e.g., a garage, will lead to the appliance turning off for longer periods so that it cannot maintain the required temperature.

▶ **WARNING!** Danger of damage from overheating. May restrict operation. Keep ventilation openings, in the appliance enclosure or in the built-in structure, clear of obstruction.

IMPORTANT SAFETY INSTRUCTIONS

- ▶ If you store fatty or greasy foods in the appliance or the appliance door, make sure that no oil or grease leaks onto the plastic parts of the appliance. This can cause the plastic to crack and break.
- ▶ Do not store explosive materials in the appliance or any products containing propellants (e.g., spray cans). Electrical components could cause flammable vapors to ignite. Danger of fire and explosion.
- ▶ Do not operate any electrical equipment (e.g., an electric ice cream maker) inside the appliance. Danger of sparking and explosion!
- ▶ Do not store cans or bottles containing carbonated drinks or liquids which could freeze in the freezer section. The cans or bottles could explode. Danger of injury and damage to the appliance!
- ▶ When cooling drinks quickly in the freezer section, make sure bottles are not left in for more than one hour; otherwise they could burst, causing injury and damage!
- ▶ Never handle frozen food or the metal parts of the appliance with wet hands. Your hands may freeze to the frozen food or to the metal. Danger of frost burn!
- ▶ Do not take ice cubes out with your bare hands and never place ice cubes or popsicles in your mouth straight from the freezer section. The very low temperature of the frozen ice or popsicles can cause frost burn to the lips and tongue. Danger of injury!
- ▶ Do not refreeze partially or fully defrosted food. Consume defrosted food as soon as possible, as it will lose its nutritional value and spoil if left for too long. Defrosted food may only be refrozen after it has been cooked.
- ▶ When eating stored food, there is a danger of food poisoning. Storage times will depend on several factors, including the freshness and quality of the food, as well as the temperature at which it is stored. Observe the manufacturer's "use-by" dates and storage instructions!
- ▶ Use only genuine original Miele parts. If parts or accessories from other manufacturers are used, the warranty may become invalid.

IMPORTANT SAFETY INSTRUCTIONS

Cleaning and care

▶ Do not use any oil or grease on the door seals. They can cause the seals to deteriorate over time.

▶ Never use a steam cleaner to clean the appliance. The steam can reach the electrical components and cause a short circuit.

▶ Never use a pointed or sharp-edged object to

- remove frost or ice
- separate frozen foods or remove ice trays

This will damage the evaporators, causing damage to the appliance.

▶ Do not place electric heaters or candles in the appliance to defrost it. These can damage the plastic parts.

▶ Do not use defrosting sprays or de-icers as they could contain substances which could damage the plastic parts or which might cause the build-up of gases and pose a danger to health.

▶ Rinse the ice cube maker and the water pipes:

- before using for the first time
- if the ice cube maker hasn't been used for a long time
- regularly if the ice cube maker is constantly on (at least once a month) to remove ice residues and prevent the water pipes from becoming blocked

- before turning off the ice cube maker for a long period of time

Transport

▶ Always transport the appliance in an upright position and in its original transport packaging to avoid damage in transit.

▶ The appliance is very heavy and must be transported by two people. Danger of injury and damage!

Disposal of your old appliance

▶ There is a risk of suffocation. Children playing can shut themselves in and suffocate.

- Take the door(s) off.
- Remove the drawers.
- Leave the storage shelves in the appliance so that children cannot easily climb into the appliance.
- ▶ Danger of electric shock.
- Cut off the plug from the power cord and discard.
- Cut off the power cord from the discarded appliance. Dispose of separately from the appliance.
- ▶ Ensure during and after disposal that the appliance isn't stored in the vicinity of gasoline or other flammable vapors and liquids.

IMPORTANT SAFETY INSTRUCTIONS

- ▶ When disposing of the appliance, ensure that the refrigeration circuit is not damaged to prevent uncontrolled escape of the refrigerant it contains (data on type plate) and oil.
- ▶ Take care not to damage any part of the cooling system, for example by
 - puncturing the coolant channels in the evaporator,
 - kinking any pipework,
 - scratching the surface coating.

Caution: Spraying coolant can damage the eyes.

**SAVE THESE
INSTRUCTIONS AND
PASS THEM ON TO ANY
FUTURE USER**





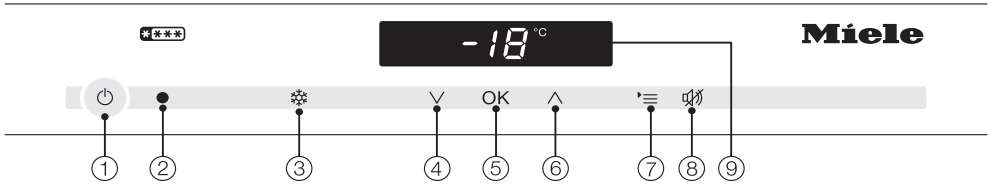

Guide to the appliance

Control panel



- ① For turning the entire appliance on and off.
- ② Optical interface (for Service use only)
- ③ For turning the SuperCool function on and off
- ④ For setting the temperature (V for colder), selection button in settings mode.
- ⑤ For confirming a selection (OK button)
- ⑥ For setting the temperature (^ for warmer), selection button in setting mode.
- ⑦ For accessing or leaving settings mode
- ⑧ For turning off the door alarm
- ⑨ Display with temperature and symbols (symbols only visible in settings mode, in the event of an alarm/message; see table for explanation of symbols)

Explanation of symbols

Symbol	Meaning	Function
	Safety lock	Prevents the user from unintentionally turning off the appliance, adjusting the temperature, turning on the SuperCool functions or entering settings.
	Acoustic signals	Selection options for the keypad tone and the door and temperature alarm tones
	Display brightness settings	For adjusting the brightness of the display
	Sabbath mode	For turning Sabbath mode on and off
	Power supply	Confirms that the appliance is connected to the electricity supply when it is not turned on; flashes when there is a power cut
	Alarm	Illuminates when the door alarm is activated; flashes in case of a temperature alarm, power failure, and additional fault messages
	Demo Mode (only visible when Demo mode is active)	For turning off Demo mode

Guide to the appliance

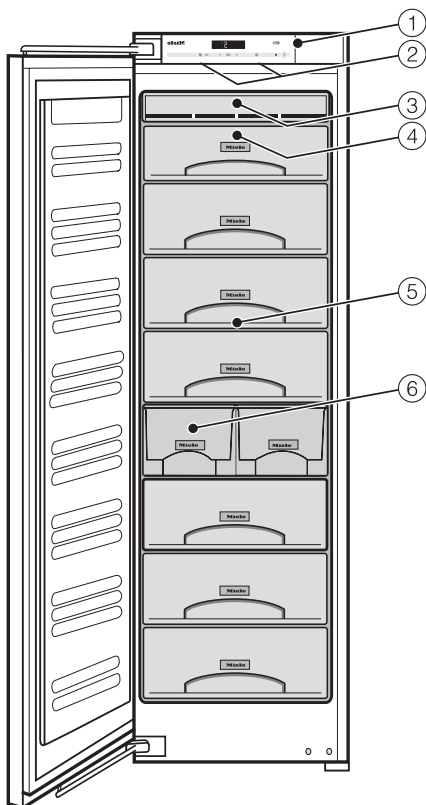

- ① Control panel
- ② Interior lighting
- ③ Frost-free unit
- ④ Top freezer drawer, can also be used as a freezing tray
- ⑤ Freezer drawers
- ⑥ Ice cube drawer with automatic ice cube maker

How to save energy

	Normal energy consumption	Increased energy consumption
Installation / maintenance	In a well-ventilated room.	In an enclosed, poorly ventilated room.
	Protected from direct sunlight.	In direct sunlight.
	Away from heat sources (radiator, range/oven).	Near a heat source (radiator, range/oven).
	Where the room temperature is ideal, i.e., around 68°F (20°C).	Where the room temperature is higher.
	Do not block the ventilation openings, and keep them free of dust.	Where the ventilation openings are blocked and full of dust.
Temperature setting	0°F (-18°C) in the freezer section	With a low temperature setting: the colder the temperature in the freezer section, the higher the energy consumption.

How to save energy

	Normal energy consumption	Increased energy consumption
Use	Drawers and shelves arranged as they were when the appliance was delivered.	
	Only open the doors when necessary and for as short a time as possible. Store food in an organized way.	Frequent opening of the door for long periods will cause a loss of coldness. The appliance works harder to cool down and the compressor runs for longer periods.
	When shopping, use a cooler box or bag and place the food in the appliance as soon as possible. Replace items removed from the appliance as soon as possible before they warm up. Allow hot food and drinks to cool down before placing them in the appliance.	Hot food or food at room temperature raises the temperature inside the appliance. The appliance works harder to cool down and the compressor runs for longer periods.
	Store food covered or wrapped.	The evaporation or condensation of liquids will cause a loss of coldness.
	Do not overfill the appliance in order to allow the air to circulate.	

Turning the appliance on and off

Before first use

Packaging material

- Remove all packaging material from the inside of the appliance.

Cleaning

Please refer to the relevant instructions in the "Cleaning and care" chapter.

- Clean the inside of the appliance and the accessories.
- Clean the ice cube maker:
After selecting the "Rinse ice cube maker" setting, the ice cube maker and the water pipes are rinsed automatically with water.

Operating the appliance

The appliance is operated with the use of touch keys activated by a finger.

A tone will sound each time a button is touched. You can deactivate this, if you wish (see "Selecting additional settings - Acoustic signals").

Turning the appliance on

Once the appliance has been connected to the electrical supply, the power supply symbol $\text{--}\text{G}$ will appear in the display after a short while.



- Touch the On/Off button.

The power supply symbol $\text{--}\text{G}$ goes out and the temperature appears in the display.

Two bars will flash in the display while the current temperature is above 32°F (0°C).

The appliance begins to cool. The temperature display and the alarm symbol \triangle will flash at the same time until the required temperature is reached.

When the appliance door is opened, the interior lighting comes on and the LED lighting becomes brighter until it reaches its maximum brightness.

To enable the temperature to get sufficiently cold inside the appliance, allow the appliance to run for a few hours before placing food in it.

Turning the appliance on and off

Turning the appliance off



- Touch the On/Off button.

If this does not work, the safety lock is activated.

The temperature will go out and the power supply symbol ⏻ will appear.

The cooling process will be turned off.

Turning off the appliance in Sabbath mode

The appliance can be turned off directly at any time.



- Touch the On/Off button.

The temperature will go out and the power supply symbol ⏻ will appear.

The interior lighting goes out and the cooling is turned off.

When the appliance is turned back on again, Sabbath mode is deactivated.

Turning off for longer periods of time

If the appliance is not needed for a longer period of time:

- turn the appliance off,
- unplug the power cord or trip the circuit breaker,
- empty the ice cube drawer,
- close the water shut-off valve,

If the appliance is not needed for a longer period of time:

- clean the appliance, and
- leave the door slightly ajar to air out the appliance.

If, during a long absence, the appliance is turned off but not cleaned out and the doors are left shut, there is a danger of bacteria and odors building up inside the appliance.

It is very important to set the correct temperature for storing food in the appliance. Bacteria will cause food which is not stored at the correct temperature to deteriorate rapidly.

To freeze fresh food and to store frozen food for a long time, a temperature of **0°F (-18°C)** is required. Partially defrosted or fully defrosted food must not be re-frozen. Food may be re-frozen once it has been cooked.

The temperature in the appliance will rise for the following reasons:

- if you open the door frequently or keep it open too long,
 - if you put too much food in it,
 - if you put food in it that is too warm,
 - if the room temperature is too high.
- The appliance is designed for use within a certain climate range (room temperature range) and should not be used outside this range.

Temperature display

In normal operation the temperature display shows the **average, current temperature in the freezer**.

Depending on the ambient temperature and the temperature setting, it can take the appliance a few hours to reach the temperature required and for this temperature to then be shown as a constant temperature in the display.

The right temperature

Sets the temperature

- Use the two buttons underneath the display to set the temperature.

By touching the button:



- the temperature will get colder



- the temperature will get warmer

While the temperature is being set, the temperature value will flash.

When you touch the buttons, you will see the following changes in the display:

- When first touched: The **last temperature selected** flashes.
- Each subsequent touch of the button:
The temperature value adjusts in 1° steps.
- Keeping your finger on the button:
The temperature changes continuously.

Approximately 5 seconds after you release the button, the **actual** temperature value in the appliance will be displayed.

When you have adjusted the temperature, wait for **approx. 6 hours if the appliance is not very full** and for **approx. 24 hours if the appliance is full** before checking the temperature display, as it will take this long for the appliance to reach the temperature.

If, after this amount of time, the temperature is too high or too low, adjust it again.

Possible setting values for the temperature

The temperature can be adjusted from 5°F to -18.4°F (-15°C to -28°C).

For best results, turn on SuperCool before putting fresh food into the freezer.

Fresh food will be frozen quickly, so that the nutritional value, vitamin content, appearance and taste are maintained.

Exceptions:

- if you have already put frozen food into the freezer.
- when freezing up to 4.5 lb (2 kg) fresh food daily.

Turning on SuperCool

When freezing small quantities of food in the freezer, the SuperCool function should be turned on **6 hours beforehand**. When freezing **the maximum load of food**, the SuperCool function should be turned on **24 hours beforehand**.



- Touch the SuperCool button so that it is highlighted in yellow.

The temperature in the appliance now begins to fall since it is operating at maximum cooling capacity.

Turning off SuperCool

The SuperCool function will turn itself off automatically after approx. 65 hours. The quantity of fresh food placed in the freezer will determine the duration before the SuperCool function turned off. The SuperCool ❄ symbol will go out and the appliance will run at normal cooling capacity again.

To save energy, the SuperCool function can be turned off once a **constant** temperature of 0°F (-18°C) is reached inside the freezer section. Check the temperature inside the appliance.



- Touch the SuperCool button so that it is no longer highlighted in yellow.

The appliance now continues running at normal cooling capacity.

Temperature and door alarm

Your appliance has been fitted with a warning system which ensures that the temperature in the freezer section cannot rise unnoticed and to avoid energy being wasted if the door is left open.

Temperature alarm

If the **freezer temperature** becomes too warm, the alarm symbol  for the freezer flashes in the display and an alarm will also sound.

The point in time at which the appliance detects a temperature range as too warm depends on the selected temperature.

The audio and visual signals are triggered, for example:

- when the appliance is turned on and the temperature in the freezer differs greatly from the set temperature,
- when too much warm air flows into the appliance, for example, when food is being re-arranged or taken out,
- when freezing large amounts of food at once,
- when there is a loss of power,
- when the appliance is defective.

The alarm will stop and the alarm symbol  will go out as soon as the temperature has dropped down to the correct level again.

However, if the temperature in the freezer remains above 0°F (-18°C) for a long time, check that the frozen food has not started to defrost. If it has, check that the food is safe to use and if it is, then use it as soon as possible or cook it before freezing it again.

Turning off the audio alarm

If the audio alarm bothers you, it can be silenced.



- Touch the button to turn off the temperature alarm.

The alarm will stop and the alarm symbol  will continue to flash until the temperature has dropped down to the correct level again.

Door alarm

An alarm will sound if the door is left open for too long. The alarm symbol  will light up.

The amount of time until the door alarm is triggered depends on the setting selected and can be either 2 minutes (factory default) or 4 minutes. However, the door alarm can also be turned off (see "Additional settings - Acoustic signals").

As soon as the door is closed, the audio alarm is silenced and the alarm symbol  will disappear from the display.

If no audio alarm sounds even though a door alarm is available, then the audio alarm has been turned off in settings mode (see "Additional settings - Acoustic signals").

Turning off the audio alarm

If the audio alarm bothers you, it can be silenced.



- Touch the button to turn off the door alarm.

The audio alarm will stop.





The alarm symbol  will continue to be displayed until the door is closed.

Selecting additional settings

Certain appliance settings can only be selected in the settings mode.

While you are in settings mode, the door alarm and any other fault messages are suppressed automatically, but the alarm symbol  lights up in the display.

Available settings

	Activating and deactivating the safety lock
	Select the temperature unit (Celsius or Fahrenheit)
	Turning acoustic signals On/Off
	Changing the brightness of the display
	Turning Sabbath mode On/Off

These settings are described in greater detail below.

Safety lock

The safety lock can be activated to prevent:

- the appliance being turned off by mistake,
- the temperature being changed by mistake,
- selection of the SuperCool function,
- settings being adjusted by mistake (it is only possible to deactivate the lock).

This prevents the appliance being turned off or settings adjusted without your knowledge, by children, for example.

Activating and deactivating the safety lock



- Touch the settings button.

All symbols available for selection will appear in the display and the  symbol flashes.



- Touch the OK button to confirm your selection.

The last selected setting flashes in the display and the  lights up.

Selecting additional settings



- By touching the \checkmark or \wedge button, you can now select whether the safety lock is activated or deactivated:
 D : the safety lock is deactivated
 I : the safety lock is activated



- Touch the OK button to confirm your selection.

The selected setting will be adopted and the  symbol will flash.



- Touch the settings button to leave the settings mode. Otherwise the appliance will exit the settings mode automatically after approximately one minute.

The  symbol will appear in the display when the safety lock is activated.

Temperature unit (Celsius or Fahrenheit)

The temperature can be displayed in either Fahrenheit $^{\circ}\text{F}$ or Celsius $^{\circ}\text{C}$.

The factory default is Fahrenheit $^{\circ}\text{F}$.

Setting the temperature display to Celsius



- Touch the settings button.

All symbols available for selection will appear in the display and the  symbol flashes.



- Touch the buttons for setting the temperature (\checkmark or \wedge) repeatedly until $^{\circ}\text{C}$ and $^{\circ}\text{F}$ flash in the display.



- Touch the OK button to confirm your selection.
 $^{\circ}\text{F}$ flashes in the display.

Selecting additional settings



- By tapping the ∇ or \blacktriangle button you can now select $^{\circ}\text{C}$.



- Touch the OK button to confirm your selection.

The selected setting will be adopted.

- Touch the settings button to leave the settings mode. Otherwise the appliance will exit the settings mode automatically after approximately one minute.

The temperature will now be displayed in Celsius.

Setting the temperature display to Fahrenheit



- Touch the settings button.

All symbols available for selection will appear in the display and the  symbol flashes.



- Touch the buttons for setting the temperature (∇ or \blacktriangle) repeatedly until $^{\circ}\text{C}$ and $^{\circ}\text{F}$ flash in the display.



- Touch the OK button to confirm your selection.

$^{\circ}\text{C}$ flashes in the display.



- By tapping the ∇ or \blacktriangle button you can now select $^{\circ}\text{F}$.



- Touch the OK button to confirm your selection.

The selected setting will be adopted.

- Touch the settings button to leave the settings mode. Otherwise the appliance will exit the settings mode automatically after approximately one minute.

The temperature will now be displayed in Fahrenheit.

Selecting additional settings

Acoustic signals 🎵

The appliance has acoustic signals such as the sensor tone and the door and temperature alarms.

You can turn the button tone or the door alarm acoustic alarm on or off, but you cannot deactivate the temperature alarm.

There are four settings to choose from. Option 3 is set the factory, i.e. the button tone and the door alarm are turned on.

Turning acoustic signals On/Off



- Touch the settings button.

All symbols available for selection will appear in the display and the 🔒 symbol flashes.



- Touch the buttons for setting the temperature (∇ or ▲) repeatedly until the 🎵 symbol flashes in the display.



- Touch the OK button to confirm your selection.

The last selected setting flashes in the display and the 🎵 lights up.



- By touching the ∇ or ▲ button you can now select:

0: button tone off; door alarm off

1: button tone off; door alarm on

(after 4 minutes)

2: button tone off; door alarm on

(after 2 minutes)

3: button tone on; door alarm on

(after 2 minutes)



- Touch the OK button to confirm your selection.

The selected setting will be adopted and the 🎵 symbol will flash.



- Touch the settings button to leave the settings mode.

Otherwise the appliance will exit the settings mode automatically after approximately one minute.

Selecting additional settings

Display brightness ☀

You can adjust the brightness of the display to suit the light conditions in the room.

The display brightness can be changed in increments from 1 to 3. The factory default setting is option 3, maximum brightness.

Changing the brightness of the display



- Touch the settings button.

All symbols available for selection will appear in the display and the  symbol flashes.



- Touch the buttons for setting the temperature (∇ or ▲) repeatedly until the ☀ symbol flashes in the display.



- Touch the OK button to confirm your selection.

The last selected setting flashes in the display and the ☀ lights up.



- By touching the ∇ or ▲ button, you can now alter the brightness of the display:
1: dimmest setting
2: medium setting
3: brightest setting.



- Touch the OK button to confirm your selection.

The selected setting will be adopted and the ☀ symbol will flash.



- Touch the settings button to leave the settings mode.
Otherwise the appliance will exit the settings mode automatically after approximately one minute.

Selecting additional settings

Sabbath mode

The appliance offers a Sabbath mode for the purposes of religious observance.

The following are turned off:

- the interior lighting when the door is opened,
- all acoustic and optical signals,
- the temperature display,
- the SuperCool function (if previously selected).

The following can be selected:

- the settings sensor for turning off Sabbath mode
- and the On/Off button,

The Sabbath mode function will turn itself off automatically after approx. 120 hours.

Temperature regulation is limited in Sabbath mode.

Ensure that the doors are properly closed, as optical and acoustic alarms are turned off. Any power failure during this time is not shown in the display. After a power failure, the appliance restarts in Sabbath mode.



Turning on Sabbath mode



- Touch the settings button.

All symbols available for selection will appear in the display and the  symbol flashes.





- Touch the buttons for setting the temperature ( or ) repeatedly until the  symbol flashes in the display.



- Touch the OK button to confirm your selection.

The last selected setting flashes in the display and the  lights up.





- By touching the  or  button, you can now turn on Sabbath mode. To do this, select setting 1.

Selecting additional settings



- Touch the OK button to confirm your selection.

The selected setting is applied, the  symbol lights up.

As soon as the  symbol goes out in the display after about 3 seconds, Sabbath mode is turned on.

- Turn off Sabbath mode after the Sabbath has passed.

Turning off Sabbath mode



- Touch the settings button to leave Sabbath mode.

The temperature will appear in the display and the interior lighting will come on.

Freezer drawers on telescopic runners

Some of the freezer drawers are on telescopic runners and can be removed for filling, emptying or cleaning purposes.

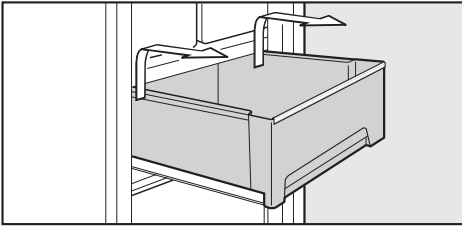

- Pull the drawer out as far as it will go.
- Holding the sides of the drawer at the back, lift it up and then forwards and out.

Push the runners back in again to avoid damaging them.

Take care when cleaning the appliance that you do not wash the special lubricant out of the telescopic runners. Wipe them with a damp cloth only.

Inserting the fruit and vegetable drawer

- Push the runners back in completely and then place the drawer on them.
- Push the drawer into the appliance until it clicks into position.

Shelves

The shelves can be removed.

- Lift the shelf slightly at the front and then pull it forwards and out.

Freezing and storing food

Always follow USDA guidelines on food safety.

WARNING!
Danger of fire
Do not use electrical appliances inside the food storage compartments of the appliance, unless they are of the type recommended by the manufacturer.

Maximum freezing capacity

To ensure that fresh food placed in the freezer freezes through to the core as quickly as possible, the maximum freezing capacity must not be exceeded. The maximum freezing capacity for freezing within a 24-hour period is given on the data plate: "Freezing capacitylbs/24 hrs."

Freezing food

Fresh food should be frozen as quickly as possible so that the nutritional value of the food, its vitamin content, appearance and flavor are maintained.

Never re-freeze partially or fully defrosted food. Defrosted food may only be re-frozen after it has been cooked.

Before placing food in the freezer

- When freezing more than 4.5 lb (2 kg) of fresh food, turn on the SuperCool function some time before placing food in the freezer (see "Using SuperCool").
This helps food which is already stored in the freezer to remain frozen.

Placing food in the freezer

The following maximum loading weights must not be exceeded:

- Top freezer drawer = 11 lb (5 kg)
- Freezer drawer = 55 lb (25 kg)
- Shelf = 77 lb (35 kg)

Unfrozen food should not touch frozen food as this will cause frozen food to begin to thaw.

- When placing items in the freezer, ensure that the packaging and containers are dry to prevent them from sticking together when frozen.

– Freezing small amounts of food

Place the food in the upper freezer drawers.

- Place the food flat in the bottom of the freezer drawer so that it freezes through to the core as quickly as possible.

When removing the upper freezer drawers, please note:
The bottom drawer must always remain in the appliance.
When placing food on the shelf, make sure that you do not block the ventilation slits in the back wall of the appliance. They are important for trouble-free operation of the appliance and normal energy consumption.

– Freezing the maximum amount (see data plate)

- Remove the upper freezer drawers.
- Place the food flat on the upper shelves so that it freezes through to the core as quickly as possible.

Once frozen:

- Place the frozen food in the freezer drawer and push it back in.

– Large items

If you wish to freeze large items such as a turkey or ham, the shelves between the drawers can be removed.

- Remove the upper freezer drawers and carefully lift and slide out the shelves.

Defrosting

Frozen food can be thawed in various ways:

- in the microwave
- at room temperature
- in the refrigerator (as it thaws, the frozen food will help cool the other food in the refrigerator)
- in a steam oven

Flat pieces of partially thawed meat or fish can be placed directly into a hot skillet.

Meat and poultry (e.g. hamburger, chicken, fish fillets) may not come into contact with other foods while defrosting. Catch the defrosting liquid and dispose of it carefully.

Fruit can be thawed at room temperature, either in the packaging or in a covered bowl.

Most vegetables can be cooked while still frozen. Just put straight into boiling water or hot fat. The cooking time is slightly less than that of fresh vegetables due to changes in the cell structure.

Never re-freeze partially or fully defrosted food. Defrosted food may only be re-frozen after it has been cooked.

Freezing and storing food

Cooling drinks quickly

When cooling drinks quickly in the freezer, make sure bottles are **not left in for more than one hour**; otherwise they could burst.

Using the cool pack

The cool pack prevents the temperature in the freezer rising too quickly in the event of a power cut. This can help prolong the storage time.

- Place the cool pack in the top drawer of the freezer section.

The cool pack will be at its most effective after it has been in the freezer for approx. 24 hours.

In the event of a power failure:

- Place the frozen cool pack directly on top of the frozen food in the front of the top drawer.

When placing fresh food in the freezer, use the cool pack to separate the fresh food from the food which is already frozen so that the frozen food does not begin to thaw.

The cool pack can also be used to keep food or drinks cool for a short period of time in a cooler box or bag.

For the automatic ice cube maker to operate it must be connected to the water supply.

Ice cube maker with integrated ice cube tray

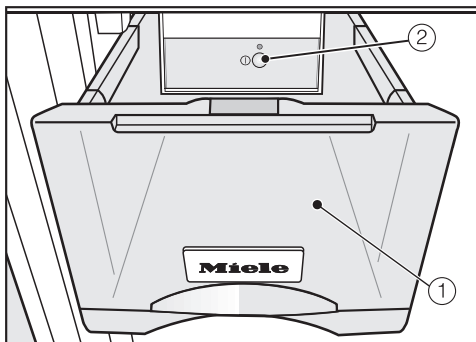

The automatic ice cube maker ② is located in the ① ice cube freezer drawer.

As soon as the ice cube maker is turned on, the  symbol lights up in the display and the indicator light illuminates on the ice cube maker.

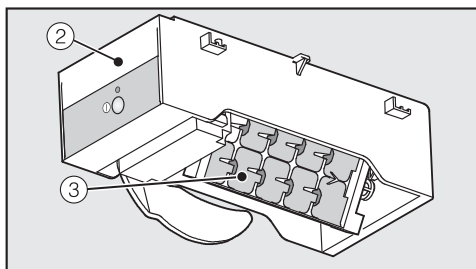

An ice cube tray ③ where ice cubes are produced is integrated in the ice cube maker ②.

The ice cube tray automatically empties into the drawer as soon as ice cubes are produced.

Rinse the ice cube maker along with the water pipes:

- before installation,
 - if the ice cube maker has not been used for a longer period of time
 - during regular daily use (at least once a month) to remove ice residues from the system (this will avoid a blockage in the water pipes) and
 - before the ice cube maker is to be turned off for a long time.
- See "Cleaning and care - Rinse the ice cube maker" on how to select this function.

Ensure the ice cube drawer is empty before turning on the ice cube maker.

Making ice cubes

Turning the ice cube maker On/Off



- Touch the settings button.

All symbols available for selection will appear in the display and the  symbol flashes.

- Touch the buttons for setting the temperature (∇ or ▲) repeatedly until the symbol for the ice cube maker  flashes in the display.
- Touch the OK button to confirm your selection.
- Touch the ∇ and ▲ buttons to set the ice cube maker:
∇: Ice cube maker is turned off
▲: Ice cube maker is turned on
- Touch the OK button to confirm your selection.

The selected setting will be adopted.

- Touch the settings button to leave settings mode,

or

- close the appliance door.

The electronics will otherwise switch to normal operation after one minute.

Make only the number of ice cubes required in your household with the ice cube maker.

The drawer must be completely shut for ice cubes to be produced.

After the appliance is turned on for the first time it can take up to 24 hours for the first ice cubes to drop out of the ice cube maker and collect in the drawer.

Thereafter, when the ice cube maker is turned off and then on again it will take up to a maximum of 6 hours for ice cubes to be produced.

The ice cube maker can be turned off independently of the freezer section if you do not want the appliance to make any ice cubes.

If the ice cube maker is turned off, the ice cube drawer can be used as an extra drawer for freezing fresh food and storing frozen food.

Making a large amount of ice cubes

The amount of ice cubes which the appliance makes depends on the temperature in the freezer section. The lower the temperature, the more ice cubes are produced within a certain time frame. At a temperature of 0°F (-18°C), approx. 2 lbs (1 kg) of ice cubes will be produced within 24 hours.

Ice cube production is halted automatically as soon as the ice cube drawer is full.

If you require a large quantity of ice cubes,

- replace the full ice cube drawer with the drawer beside it on the right.

The ice cube maker will begin to produce ice cubes again as soon as this new drawer has been placed in position and closed properly.

Changing the size of the ice cubes

The size of the ice cubes depends on the quantity of water being taken in. You are able to set this quantity according to your wishes.

Setting the water quantity

The size of the produced ice cube depends on the water pressure and set water intake time of the ice cube maker. If, for example, the ice cube maker only makes small ice cubes, the water pressure is low. To produce larger ice cubes, the water quantity of the ice cube maker must be increased. A medium-sized water quantity (*E3*) has been set at the factory.

The setting can only be selected if the ice cube maker is turned on.



- Touch the settings button.

All symbols available for selection will appear in the display and the  symbol flashes.

- Touch the buttons for setting the temperature (∇ or \wedge) repeatedly until the symbol for the ice cube maker  flashes in the display.
- Touch the OK button to confirm your selection.
- The ∇ and \wedge buttons can be used to set whether the water quantity is to be changed:
 - 0*: Ice cube maker is switched off
 - 1*: Ice cube maker is switched on
 - 2*: **Set the water quantity**
 - 3*: Ice cube tray cleaning position
 - 4*: Rinse the ice cube maker
- Touch the OK button to confirm your selection.
- Touch the ∇ and \wedge buttons to set the required water quantity (*E1* to *E8*):
 - E1*: small quantity
 - E8*: large quantity
- Touch the OK button to confirm your selection.

The selected setting will be adopted.

- Touch the settings button to leave settings mode,

or

- close the appliance door.



The electronics will otherwise switch to normal operation after one minute.

Making ice cubes

Turning the ice cube maker On/Off with the On/Off button

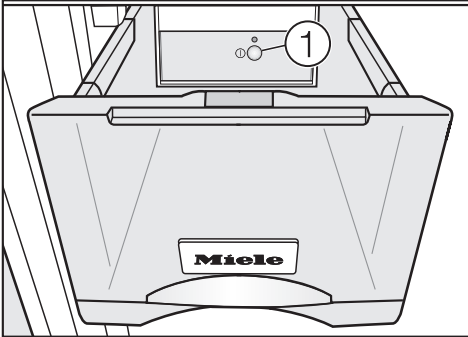
- Open the ice cube drawer slightly.



- Press and hold the On/Off button ① on the ice cube maker
 - until the indicator light comes on. The symbol for the ice cube maker  will appear in the display. The ice cube maker is now on.
 - until the indicator light goes out. The symbol for the ice cube maker  will disappear from the display. The ice cube maker is now off.
- Close the ice cube drawer.

WARNING! Risk of injury and damage.
Do not use mechanical devices or other means to accelerate the defrosting process, other than those recommended by the manufacturer.

The appliance is equipped with a "NoFrost" system for automatic defrosting as needed.

The moisture generated in the appliance collects on the condenser, and is automatically defrosted and evaporates periodically.

This automatic defrosting system enables the freezer to remain permanently ice-free, but the food stored in the freezer will not defrost.

Cleaning

WARNING!

Danger of electric shock.
Unplug refrigerator or disconnect power.

Danger of fire.
Do not damage the refrigerant circuit.

Do not let water get into the electronic unit.

Cleaning water must not get into the drain hole.

Do not use a steam cleaner to clean the appliance. Steam could reach electrical components and cause a short circuit.

The data plate located inside the appliance must not be removed. It contains information which is required in the event of a service call.

Information regarding cleaning agents

To better maintain your appliance **avoid** the following:

- cleaning products containing soda, ammonia, acid or chloride
- lime removers
- abrasive cleaning products, such as scouring powder, scouring liquid, or pumice stones
- cleaners containing solvents
- stainless steel cleaners
- dishwasher detergent
- oven sprays
- hard, abrasive sponges and brushes, such as pot scrubbers
- eraser sponges
- sharp metal scrapers

Glass cleaners may be used to clean the exterior. However **do not** allow them to sit or "puddle", this can cause damage to the surface.
Remove the cleaner promptly.

Cleaning and conditioning agents used inside the appliance must be food safe.

Use warm water and liquid dish soap.

The following pages contain important information on cleaning.

Rinsing the ice cube maker

Rinse out the ice cube maker and the water pipes:

- before using for the first time,
- if the ice cube maker has not been used for quite a while,
- regularly (at least once a month) if it is constantly being used, to remove any ice residues and therefore avoid any blockages in the water pipes, and
- before switching the ice cube maker off for an extended period of time.

Ensure the ice cube drawer is empty before selecting the "Rinse the ice cube maker" setting. The water will otherwise flow onto the contents of the drawer.

"Rinse the ice cube maker" can only be selected when the ice cube maker is switched on.

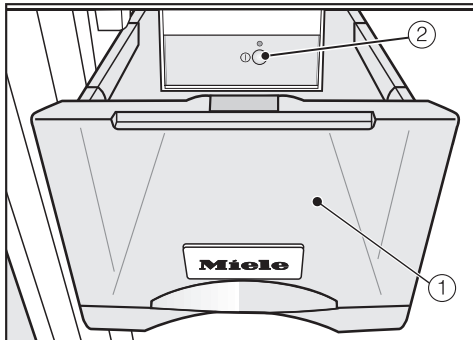



After selecting "Rinse the ice cube maker," the ice cube maker ② and the water pipes will automatically be rinsed.

The ice cube tray will turn to the cleaning position so that it can be dried by hand.

The water is collected in the ice cube drawer ①.

- Touch the settings button.

All symbols available for selection will appear in the display and the  symbol flashes.

- Touch the buttons for setting the temperature (∨ or ∧) repeatedly until the symbol for the ice cube maker  flashes in the display.
- Touch the OK button to confirm your selection.
- The required setting can be selected by touching the X and Y buttons:
 - 0: Ice cube maker is switched off
 - 1: Ice cube maker is switched on
 - 2: Set the water quantity
 - 3: Set cleaning position for the ice cube tray
 - 4: **Rinse the ice cube maker**

Cleaning

- Touch the OK button to confirm your selection.

The selected setting will be saved. The ice cube maker symbol  will flash in the display and the indicator light will flash on the ice cube maker as long as the ice cube maker is being rinsed.

You will hear the ice cube tray turning to a slanted position.

- Wait until the rotation has stopped before continuing.

The ice cube maker will then turn off.

- Carefully remove the ice cube drawer which is now filled with water. Then empty and clean it.

The ice cube tray is **not** removable and can only be cleaned when in place.

- Dry the ice cube tray ② with a soft cloth.

As soon as the ice cube maker is turned on, the ice cube tray rotates back to its original position.

Cleaning the ice cube tray

Clean the ice cube maker:

- before switching off the ice cube maker for an extended period of time,
- regularly to remove any ice and water residues.

If you have already selected the setting "Rinse the ice cube maker" (see "Rinsing the ice cube maker"), the ice cube tray will already be in the cleaning position.

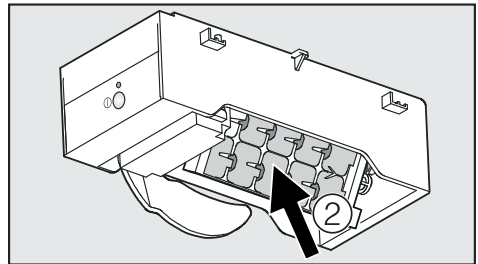

The ice cube tray ② is **not** removable and can only be cleaned when in place. You can therefore place the ice cube tray in the cleaning position.

Setting the cleaning position

The setting can only be selected if the ice cube maker is turned on.

- Empty the ice cube drawer.



- Touch the settings button.

All symbols available for selection will appear in the display and the  symbol flashes.

- Touch the buttons for setting the temperature (∇ or ▲) repeatedly until the symbol for the ice cube maker  flashes in the display.
- Touch the OK button to confirm your selection.

- The required setting can be selected by touching the X and Y buttons:

0: Ice cube maker is turned off

1: Ice cube maker is turned on

2: Set the water quantity

3: **Set cleaning position for the ice cube tray**

4: Rinse the ice cube maker

- Touch the OK button to confirm your selection.

The selected setting is saved and you will hear the ice cube tray moving into a slanted position.

- Wait until the rotation has stopped before continuing.

The ice cube maker will then switch off. The symbol for the ice cube maker  will disappear from the display.

- Remove and clean the ice cube drawer.

The ice cube tray is **not** removable and can only be cleaned when in place.

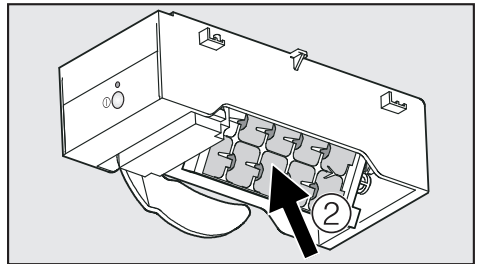

- Clean the ice cube tray **2**.

As soon as the ice cube maker is turned on, the ice cube tray rotates back to its original position.

Cleaning

Before cleaning

- Turn off the appliance.
The display goes out and cooling is turned off.
If this does not happen, then the safety lock is still activated (see "Selecting additional settings - Deactivating the lock").
- Unplug the appliance or trip the circuit breaker.
- Take any food out of the appliance and store it in a cool place.
- Remove the shelves:
Lift them up at the front slightly and then pull them forwards and out.

The telescopic runners on the shelves are **not** dishwasher safe.

To remove the telescopic runners:

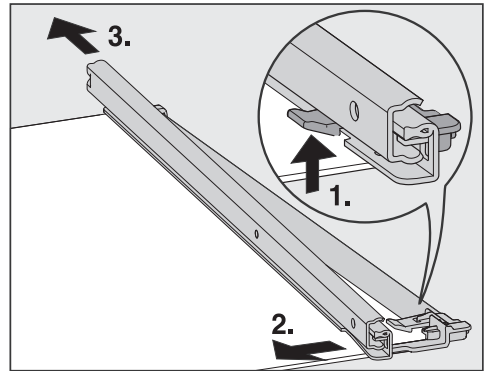

- 1. Press the catch up.
- 2. Push the telescopic runner to the side and then 3. backwards.

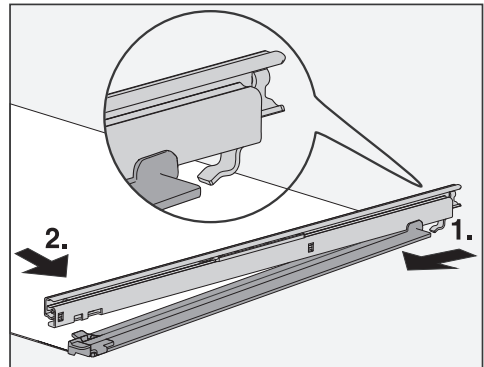

- After cleaning, reattach the telescopic runners to the shelf.
To do this, hook the telescopic runner onto the shelf and then click the catch into position.

Interior and accessories

Clean the appliance at least once a month.

Remove any soiling immediately so that it does not dry up.

- Clean the interior and any accessories with warm water and liquid dish soap applied with a soft sponge. After cleaning, wipe with a clean, damp cloth and then dry with a soft cloth.

The ice cube tray is **dishwasher safe**.

The maximum temperature of the dishwashing program selected must not exceed 130°F (55°C). Contact with natural dyes from carrots, tomatoes and ketchup may discolor the plastic parts in the dishwasher. This discoloring does not affect the stability of the parts.

The following parts **cannot be cleaned in a dishwasher**:

- the ice cube drawer
- the freezer drawers
- the shelves
- the telescopic runners on the shelves
- the cool packs
- Wipe the telescopic runners with a damp cloth to clean them.

Be careful not to wash out the special lubricant in the telescopic runners during cleaning.

- Clean all other parts and accessories by hand.
- Leave the door open to air the appliance for a short while.

Cleaning

Ventilation slits

- The ventilation slits should be cleaned on a regular basis with a brush or vacuum cleaner. A build-up of dust will increase the energy consumption of the appliance.

Door seal

Do not use any grease or oil on the door seal as these will cause the seal to deteriorate and become porous over time.

- The door seal should be cleaned regularly with clean water and then wiped thoroughly dry with a soft cloth.

After cleaning

- Slide all shelves back into the appliance.
- Close the appliance door.
- Connect the appliance again and turn it on.
- Turn on the SuperCool function in the freezer to cool it down quickly.
- Place the freezer drawers with the frozen food back in the freezer.
- As soon as the freezer section reaches a constant temperature of at least 0°F (-18°C), press the SuperCool button to turn off the function.



Frequently asked questions

With the aid of the following guide minor problems can be corrected without a service call.

If, having followed the suggestions below, you still cannot resolve the problem, please contact Miele Technical Service.

To prevent cold from escaping, open the appliance doors as little as possible until the malfunction has been corrected.

Repairs should only be carried out by a qualified and trained person in strict accordance with local and national safety regulations. Unauthorized repairs could cause personal injury or machine damage and may void the warranty.

Problem	Possible cause	Solution
<p>The appliance does not get cold and the display is not lit up.</p>	<p>The appliance is not turned on and the power supply symbol  is lit up in the display.</p>	<p>■ Touch the On/Off button.</p>
	<p>The plug is not properly plugged into the electrical outlet.</p>	<p>■ Insert the plug correctly into the socket. The power supply symbol  appears in the display when the appliance is turned off.</p>
	<p>Check whether the fuse has tripped. There could be a fault with the appliance, the household electrical wiring or another electrical appliance.</p>	<p>■ Contact a qualified electrician or Miele Technical Service for assistance.</p>
<p>The appliance does not get cold, although the controls and the interior lighting are working.</p>	<p>Demo mode is turned on and the  symbol lights up in the display. This allows the appliance to be presented in the showroom without the cooling system being turned on. Do not activate this setting for domestic use.</p>	<p>■ Turn off Demo mode (see "Information for dealers - Demo mode").</p>

Frequently asked questions

The compressor runs more and more often and for longer periods of time, and the temperature in the appliance drops.		
Problem	Possible cause	Solution
The temperature in the appliance is too low.	The temperature setting is too low.	■ Correct the temperature setting.
	The door is not properly closed.	■ Check why the appliance door is not closing properly.
	A large amount of food is being frozen at once.	■ See "Freezing and storing food".
	The SuperCool function for the freezer is still turned on. It will turn itself off automatically after approx. 65 hours.	You can turn off the SuperCool function earlier to save energy. ■ Press the SuperCool button.
The compressor runs continuously.	To save energy, the compressor runs at a lower speed, but for longer, when less cooling is required. In this way, the running time of the compressor is extended.	None

Frequently asked questions





The compressor runs more and more often and for longer periods of time, and the temperature in the appliance drops.		
Problem	Possible cause	Solution
The compressor is turning on more frequently and for longer periods.	The ventilation slits in the housing unit have been covered or become too dusty.	<ul style="list-style-type: none"> ■ Do not block the ventilation slits. ■ Clean the ventilation slits on a regular basis.
	The door has been opened too frequently, or a large amount of food has been put in at once.	<ul style="list-style-type: none"> ■ Only open the door when necessary and for as short a time as possible. <p>After a while the temperature will return to normal by itself.</p>
	The door is not properly closed. A thick layer of ice may have developed in the freezer section.	<ul style="list-style-type: none"> ■ Close the door. <p>After a while the temperature will return to normal by itself.</p> <p>If a thick layer of ice has formed, it will decrease the cooling capacity and increase the energy consumption.</p> <ul style="list-style-type: none"> ■ Defrost the freezer section and clean it.
	The room is too warm. The higher the room temperature, the longer the compressor has to run.	<ul style="list-style-type: none"> ■ See "Installation location".
	The appliance was not properly installed in the niche.	<ul style="list-style-type: none"> ■ See "Installation" and "Installing the appliance".

Frequently asked questions



The compressor comes on less and less often and for shorter periods of time, the temperature in the appliance rises.

Problem	Possible cause	Solution
The temperature in the appliance is too high.	This is not a fault.	<ul style="list-style-type: none">■ Correct the temperature setting.■ Check the temperature again after 24 hours.
The food begins to thaw.	The room temperature is too low for this appliance. If the room temperature is too low, the compressor will run less frequently. This may cause the freezer to become too warm.	<ul style="list-style-type: none">■ See "Installation location".■ Increase the room temperature.

Frequently asked questions

Indication in the display		
Problem	Possible cause	Solution
"F0 to F9" appears in the display.	There is a fault.	■ Contact Miele Technical Service.
"FE*" appears in the display.	There is a fault.	■ Contact Miele Technical Service.
The  symbol flashes and the indicator light on the ice cube maker flashes when the ice cube maker is turned on.	The water supply line is not open.	■ Open the water intake.
The  and  symbols flash. The indicator light on the ice cube maker also flashes.	There is a fault with the ice cube maker.	■ Contact Miele Technical Service.
The alarm symbol  lights up in the display together with a refrigerator section button, and an acoustic alarm can be heard.	The door alarm has been activated.	■ Close the appliance door. The alarm symbol  will go out and the acoustic alarm will stop.



Frequently asked questions

Indication in the display		
Problem	Possible cause	Solution
<p>The alarm symbol  flashes in the display.</p>	<p>The temperature in the freezer has risen higher or fallen lower than the temperature which has been set. This could be due to:</p> <ul style="list-style-type: none"> – the door being opened too frequently. – a large quantity of fresh food has been placed in the freezer at once without turning on the SuperCool function. – there has been a lengthy interruption of the power supply. 	<ul style="list-style-type: none"> ■ Remedy the alarm. The alarm symbol  will disappear and the audible tone will stop. Depending on the temperature, check whether the food has defrosted or started to defrost. If this is the case, cook the food before freezing again.
<p>The acoustic alarm sounds and the power failure symbol  appears in the display.</p> <p>The temperature display also shows the warmest temperature recorded in the freezer during the loss of power or interruption of the electricity supply.</p>	<p>The temperature in the appliance rose too much over the past days or hours because of a power outage or interruption of the electrical supply.</p> <p>The appliance will go back to the last temperature setting when the power is back on.</p>	<ul style="list-style-type: none"> ■ Touch the Alarm Off button. <p>The warmest temperature display will go out. The display will then revert to showing the current temperature in the freezer section.</p> <ul style="list-style-type: none"> ■ Depending on the temperature displayed, you should check the condition of food in the freezer. If it has defrosted or started to defrost, check that it is still safe to use and, if so, use it as soon as possible. Defrosted food may only be re-frozen after it has been cooked.

Frequently asked questions

Interior lighting		
Problem	Possible cause	Solution
The LED lighting is not working.	To avoid overheating, the lighting turns itself off automatically after approx. 15 minutes if the door is left open.	<ul style="list-style-type: none"> ■ Close the appliance door. <p>When the door is opened again, the interior lighting will come on.</p>
	If this is not the case, then there is a fault.	<ul style="list-style-type: none"> ■ Contact Miele Technical Service. <p>The LED lighting may only be repaired or replaced by Miele Technical Service. There are live electrical components under the lighting cover. Danger of injury and damage to the appliance.</p> <div style="border: 1px solid gray; padding: 5px;"> <p>Do not remove the cover. If the cover is damaged or needs to be removed due to damage, use caution. There are lasers in the lighting (laser beam class 1M) which you should avoid looking at directly. Do not use optical instruments (magnifying glass or similar) to look at the lighting either.</p> </div>

Frequently asked questions

Problems with the ice cube maker		
Problem	Possible cause	Solution
You cannot turn the ice cube maker on.	The appliance is not connected to the power supply or is not turned on.	■ Connect the appliance and turn it on.
The ice cube maker does not produce any ice cubes.	The appliance or the ice cube maker is not turned on.	■ Turn the appliance and the ice cube maker on.
	The water supply line is not open.	■ Open the water intake.
	The drawer of the ice cube maker is not closed properly.	■ Push the drawer all the way in.
	The ice cube tray is not positioned correctly.	■ Correct the position of the ice cube tray.
	The temperature in the freezer section is too high.	■ Select a lower temperature.
The  symbol flashes and the indicator light on the ice cube maker flashes when the ice cube maker is turned on.	The water supply line is not open.	■ Open the water intake.
The  and  symbols flash. The indicator light on the ice cube maker also flashes.	The is a fault with the ice cube maker.	■ Contact Miele Technical Service.

Frequently asked questions

Other problems		
Problem	Possible cause	Solution
Food has frozen together or to the wall.	The food packaging was not dry when loaded in the freezer.	■ Use a blunt instrument (such as a spoon handle) to carefully pry them apart.
There is no acoustic alarm although the door has been open for a long time.	This is not a fault. The alarm tone has been turned off in settings mode (see "Selecting additional settings - Acoustic signals").	None
The appliance cannot be turned off.	The safety lock is activated. The  symbol is lit up in the display.	■ Turn off the safety lock (see "Selecting settings - deactivating the safety lock").
The external walls of the appliance feel warm.	This is not a fault. The warmth created by the evaporator is used to prevent condensation.	None

Noises

Normal noises	What causes them
Brrrrr...	This noise may get louder for brief periods when the motor kicks on.
Blub, blub....	A gurgling noise can be heard when the refrigerant circulates through the pipes.
Click....	Clicking sounds occur whenever the thermostat turns the motor on or off.
Sssrrrrr....	In multi-section and frost-free appliances, the movement of air circulating through the appliance can sometimes just barely be heard.
	In appliances with a water tank, a humming noise can be heard when the water pump is running.
Crack...	A cracking noise can be heard when the appliance materials expand.

Keep in mind that a certain amount of noise is unavoidable (from the compressor and the refrigerant circulating through the system).

Noises that you can easily eliminate	Possible cause	Solution
Rattling, clinking	The appliance is not level.	Realign the appliance using a level, by raising or lowering the screw feet underneath the appliance.
	The appliance is touching another appliance or piece of furniture.	Move it away.
	Drawers, baskets or shelves are jiggling or are stuck.	Check all removable items and refit them correctly.
	Bottles or containers are touching.	Separate them.
	The transport cord clips are still hanging on the back of the appliance.	Remove the cord clips.

Service / Warranty

In the event of a fault which you cannot correct yourself, please contact

- your Miele dealer

or

- Miele Technical Service.

See back cover of the this manual contact details.

When contacting Miele Technical Service, please quote the model and serial number of your appliance. This information is given on the data plate inside your appliance.

Warranty

For additional information, please refer to your warranty booklet.

See the end of these operating and installation instructions for this telephone number.

Demo mode

This appliance can be presented in retail stores and in showrooms with the help of the "Demo mode." The controls and lighting will still work, but the compressor will not operate.

Switching on the Demo mode



- Switch the appliance off by tapping the On/Off button.

If this does not work, the safety lock is still activated.

The temperature will go out and the mains connection symbol  will appear.





- Place your finger on the V button and hold it there.



- At the same time, briefly tap the On/Off button (without letting go of the V button).



- Keep your finger on the V button until the  symbol appears in the display.
- Then, take your finger off the V button.

Demo mode is switched on and the  symbol is illuminated in the display.

Information for dealers/showrooms

Switching off Demo mode

The  is illuminated in the display.



- Tap the settings button.

All symbols available for selection will appear in the display and the  symbol flashes.



- Tap the buttons for setting the temperature (∇ or ▲) repeatedly until the  symbol flashes in the display.



- Tap the OK button to confirm your selection.

 flashes in the display (Demo mode is active) and the  symbol is illuminated.



- Tap the ∇ or ▲ button so that  appears in the display (Demo mode is inactive).



- Tap the OK button to confirm your selection.

The selected setting will be adopted and the  symbol will flash.



- Tap the settings button to leave the settings mode. Otherwise the appliance exits the settings mode automatically after approximately one minute.

The Demo mode is switched off and the  symbol disappears.

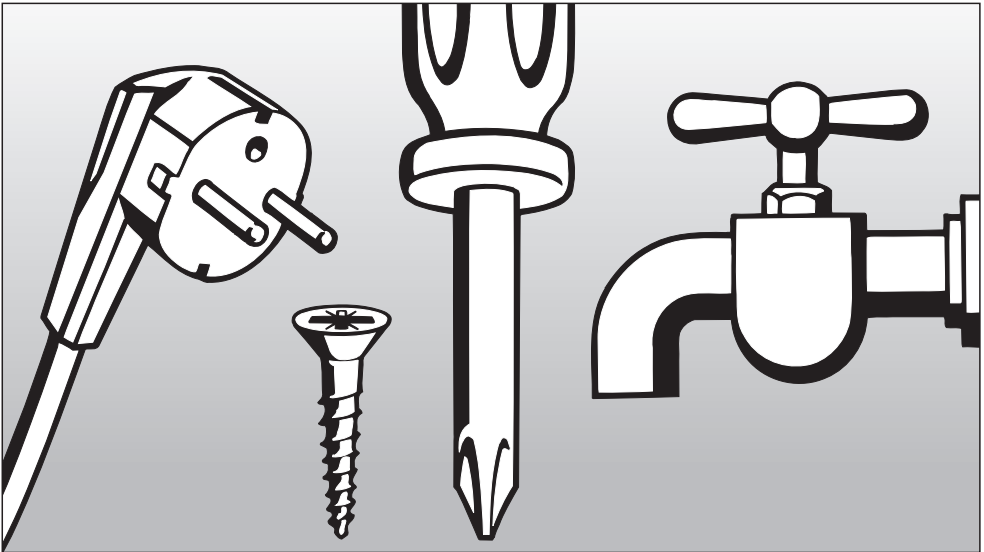

Installation Instructions

Information is subject to change. Please refer to our website to obtain the most current product specification, technical & warranty information.

To prevent accidents
and machine damage
read these instructions

before
installation or use.

Disposing of the packaging materials

The packaging is designed to protect the appliance from damage during transportation. The packaging materials used are selected from materials which are environmentally friendly for disposal and should be recycled.

Ensure that any plastic wrappings, bags, etc. are disposed of safely and kept out of the reach of children. Return the packaging to your dealer.

Disposal of your old appliance

Old appliances may contain materials that can be recycled. Please contact your local recycling authority about the possibility of recycling these materials.

Please take care not to damage the pipework while the appliance is being stored for transport to a waste disposal facility.

By protecting the pipework, you help keep the coolants and compressor oil from contaminating the environment.

Before discarding an old appliance disconnect it from the electrical supply and cut off the power cord to prevent it from becoming a hazard.

Plumbing

Information regarding the water connection

All plumbing work should be carried out by a suitable qualified person, in accordance with local and national regulations.

Disconnect the appliance from the power supply before connecting it to the water supply.

Before connecting the water hose for the ice cube maker, ensure the water supply is completely turned off.

The water being used should meet the drinking water standards of the country where the machine is used.

All devices used for connecting the appliance to the water supply must comply with the current national and local safety regulations in the country in which the appliance is being installed.

All units and systems used to supply water to the appliance must also comply with the applicable requirements of the respective country.

The appliance must be connected to a cold water line that:

- is directly connected to the fresh water supply in order to ensure a circulation of the water in the cold water line.

Avoid using a water line in which the water is allowed to pool. This can affect the taste of water and ice cubes.

- withstands the operating pressure.
- fulfills the hygiene regulations.

The water pressure must be between 22 and 87 psi (1.5 and 6 bar).

A shut-off valve must be provided between the water line and the water supply of the building to ensure that the water supply can be cut off if necessary.

The water supply should be easily accessible after the machine has been built in.

Before commissioning, the water line needs to be vented by a qualified technician:

The water connection can be found at the back of the appliance. The solenoid valve ② has a 3/4" connection thread.

The connection parts included with the appliance permit the connection of various water lines (a water line is not included in delivery).

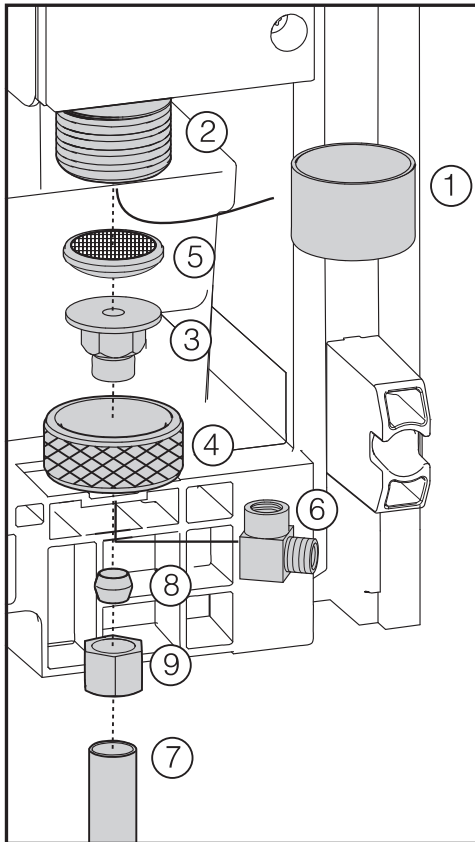

⚠ In the following, please note: inserting the water filter incorrectly can cause damage!

- Place the water filter ⑤ on top of the adapter ③ as shown in the picture.

⚠ Do not over-tighten the union nut, damage can result!

- Connect the union nut ④ to the solenoid valve ② and tighten it.
- If you want to divert the water line by 90°, screw on the elbow ⑥.

In case of a water line with a 1/4" thread:

- Connect the water line ⑦ (e.g., copper) using the clamping ring ⑧ and the nut ⑨ on the adapter ③ or elbow ⑥.

In case of a water line with a 7/16" 24-UNS thread:

- Connect the water line ⑦ directly to the adapter ③ or elbow ⑥ (a clamping ring ⑧ and nut ⑨ are not required).

- Remove the cap ① from the solenoid valve ②.
- Insert the adapter ③ into the union nut ④.

Plumbing

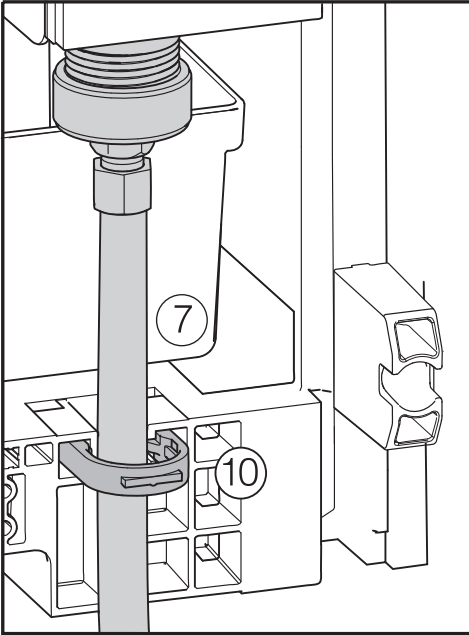

Caution! Risk of damage to the ice cube maker! During the operation of the ice cube maker, do not interrupt the water supply.

- Secure the water line ⑦ using the retaining clip ⑩.
- Slowly open the water shut-off valve and check for leaks.
- The appliance can now be connected to the power supply (see "Electrical connection").
- Slide the appliance into the desired position.

When doing so, make sure that the water does not get kinked or damaged.

After a maximum of 24 hours, the first ice cubes will drop out of the ice cube maker and collect in the drawer.

 Failure to follow these instructions can result in death, fire, or electrical shock.

Improper connection of the equipment grounding conductor may result in electric shock. If you are in any doubt as to whether the appliance has been properly grounded, have the appliance checked by a qualified electrician or service technician.

Installation, repairs and other work by unqualified persons could be dangerous. The manufacturer will not be held responsible for damage or injury arising from unauthorized work.

Before installing the appliance, verify that the voltage, load and circuit rating information found on the data plate match the household electrical supply.

 To guarantee the electrical safety of this appliance, continuity must exist between the appliance and an effective grounding system. It is imperative that this basic safety requirement be met. If there is any doubt, have the electrical system of the house checked by a qualified electrician.

 This appliance is equipped with a three-prong grounding plug to prevent shock hazards. It should be plugged directly into a properly grounded outlet. Do not cut or remove the grounding prong from the plug. If the plug does not fit the outlet, have the proper outlet installed by a licensed electrician. Do not use extension cords or ungrounded (two prong) adapters.

Connect this appliance to a 110 – 120 VAC, 60 Hz and 15 amp (20 amp for side-by-side) circuit with a circuit breaker or fuse.

This appliance must be grounded according to local or national codes.

Electrical connection

The appliance must be connected to an electrical outlet that is properly grounded. The electrical installation must comply with the applicable electrical code.

The plug must be easily accessible and not concealed behind the appliance so that the appliance can quickly be disconnected from the electricity supply in an emergency. In addition, no other appliances should be plugged into a socket located directly behind this appliance.

The power cord must not come into contact with the back of the appliance, as they could be damaged by vibrations from the appliance. This may result in a short circuit.

Do not use an extension cord to connect the appliance to the power supply. Extension cords do not guarantee the required safety of the appliance (e.g. they pose a danger of overheating).

Do not connect the appliance to stand-alone inverters, such as those used with an autonomous energy source, **e.g. solar power systems**. Otherwise, when the appliance is switched on, peak loads in the system can cause the safety shutdown mechanism to be triggered. This can damage electronic units. In addition, the appliance must not be used with **energy-saving devices**, which reduce the amount of energy supplied to the appliance and cause it to overheat.

If the power cord needs to be replaced, this work must only be performed by a qualified electrician.

To avoid tipping over, the appliance must be properly installed and secured.

WARNING!

Danger of tilting! To avoid a hazard due to instability of the appliance, it must be secured in accordance with the instructions.

Side-by-side

The FNS 37492 iE refrigerator/freezer has two side-wall heaters encased in foam and can be built into separate cabinet units arranged side-by-side with all appliances.

Please contact your dealer for specific information about which combinations will work with your appliance.

Location

This appliance should not be installed where it is exposed to direct sunlight or directly adjacent to a heat-producing appliance such as an oven or a radiator. The higher the ambient temperature of the room, the longer the compressor runs, and the more energy the appliance requires to operate. The appliance should be installed in a dry, well ventilated room.

The following should also be taken into consideration:

- The electrical socket must be easily accessible in an emergency, not concealed behind the appliance.

- The plug and cord must not touch the rear of the appliance as they could be damaged by vibrations from the appliance.
- Do not plug in other devices behind this appliance.

Important! In environments with high humidity

condensation can build up on the appliance exterior and ultimately cause corrosion on the outer walls.

To prevent this from happening, we recommend installing the appliance in a dry and/or an air-conditioned room with sufficient ventilation.

Once you have completed the installation, please make sure that the appliance door closes properly, that the ventilation openings are not covered and that the appliance has been installed as described.

Climate class

The appliance is designed for use within a certain climate range (ambient temperatures) and should not be used outside this range. The climate range of the appliance is stated on the data plate inside the appliance.

Climate class	Room temperature
SN	+50°F to +90°F (+10°C to +32°C)
N	+60°F to +90°F (+16°C to +32°C)
ST	+60°F to +100°F (+16°C to +38°C)
T	+100°F to 110°F (+16°C to +43°C)

Operating in a room which is too cold will cause the compressor to turn off for too long, causing the internal temperature in the appliance to rise resulting in damage.

Installation information

Ventilation

WARNING! Danger of damage from overheating. May restrict operation. Keep ventilation openings, in the appliance enclosure or in the built-in structure, clear of obstruction.

The ventilation gaps given must be observed, otherwise the compressor will run more frequently and for longer periods. This will result in increased energy consumption and a higher operating temperature for the compressor. This may, in turn, cause the compressor to be damaged.

Air at the back of the appliance gets warm. The appliance housing unit must therefore be constructed to allow sufficient space for ventilation (see "Installation dimensions"):

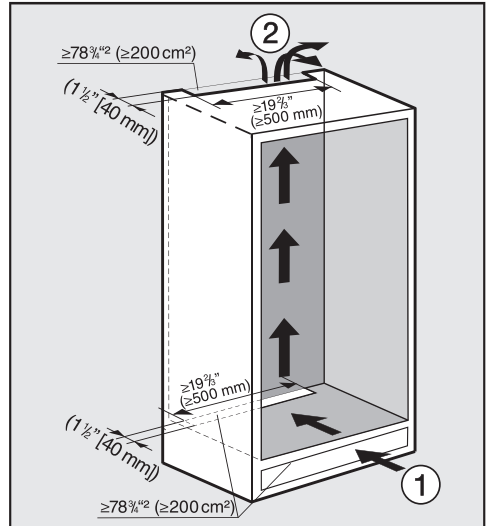

- Air intake ① occurs via the plinth at the bottom of the appliance and the air escapes at the top ② at the rear of the housing unit.
- A ventilation gap of at least $1 \frac{5}{8}''$ (40 mm) depth must be provided behind the appliance for air to circulate.
- The ventilation cross-sections in the plinth, housing unit and above the appliance must amount to at least $78 \frac{3}{4}''^2$ to ensure that air can circulate without obstruction.
- Important. The appliance uses less energy, the larger the ventilation cross-section.

The ventilation cross-sections must not be blocked or covered in any way. They also need to be dusted/cleaned on a regular basis.

Top ventilation cross-section

The ventilation cross section at the top of the appliance can be constructed in different ways:

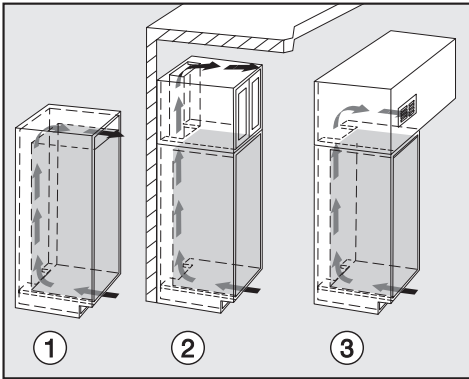

- ① directly above the appliance with a ventilation grille (free airflow of at least $78 \frac{3}{4}''^2$).
- ② in between the housing unit and the ceiling.
- ③ through a suspended ceiling.

Ventilation slits

If you would like to use the ventilation slits, proceed as follows:

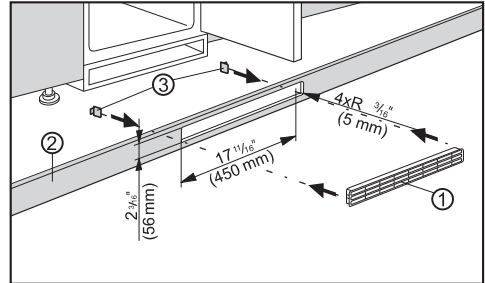

- Cut an opening in the plinth ② as shown in the figure.
- Place the ventilation slits ① into the opening.
- Push the snap connector ③ into the ventilation slits from the rear until the hooks are touching the plinth.
- Reinstall the plinth with the ventilation slits.

Installation information

Before installation

- Before installation, remove the accessories bag containing installation components and accessories from the appliance, and remove the sealing strip from the appliance door.
- **Do not remove** the following from the back of the appliance:

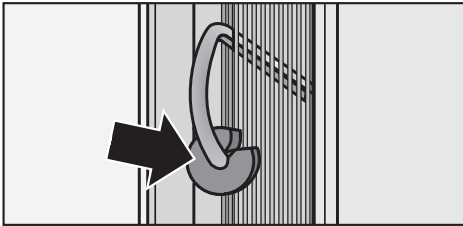

- The spacers (depending on model). These ensure the gap required between the back of the appliance and the wall is maintained.
- Depending on model, the pouches located in the metal grille (heat exchanger). They are required for the correct functioning of the appliance. The contents are not poisonous or dangerous.
- Remove any cable clips from the back of the appliance.
- Check that all parts at the back of the appliance are unhindered. Carefully remove any hindrance.

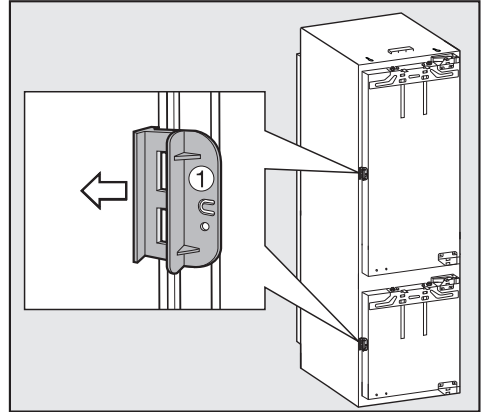

- Remove the red transport safety device ① and close the created hole with the included stopper ②.

Wall spacer on the rear side

At a furniture depth below 21 3/4" (553 mm), you can remove the wall spacer from the rear side of the appliance so that you can push the appliance completely into the niche. The removal of the wall spacer can lead to a higher energy consumption since the ventilation cross-section is reduced.

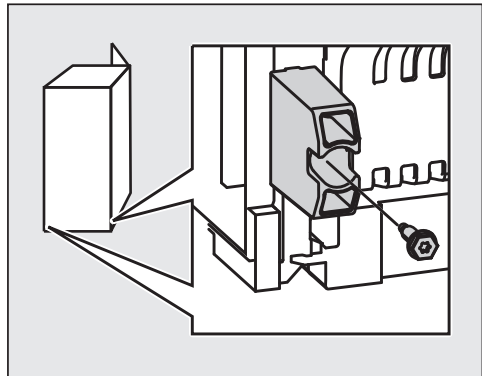

- Loosen the screw and remove the wall spacer.

Installation dimensions

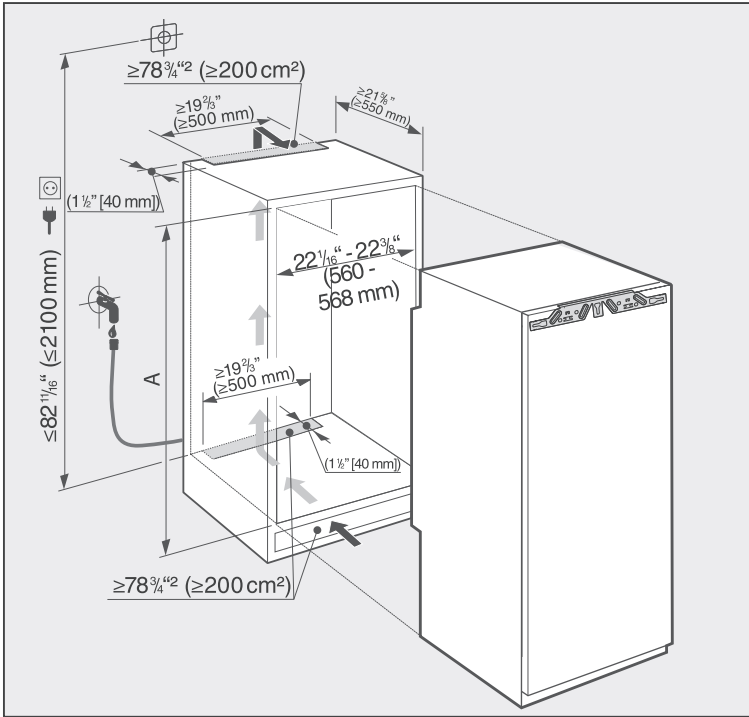

Before installation, ensure the building-in niche is the correct size. The specified ventilation cross-sections must be adhered to in order to ensure the correct functioning of the appliance.

	Niche height A
FNS 37492 iE	69 3/4" - 70 3/8" (1772 - 1788 mm)

Adjusting the door hinge

The door hinges are factory set so that the door can be opened wide.

However if the opening angle of the door needs to be limited for any reason, the hinge can be adjusted to accommodate this.

If, for instance, when it is opened the appliance door would hit an adjacent wall, you should limit the opening angle of the appliance door to 90°:

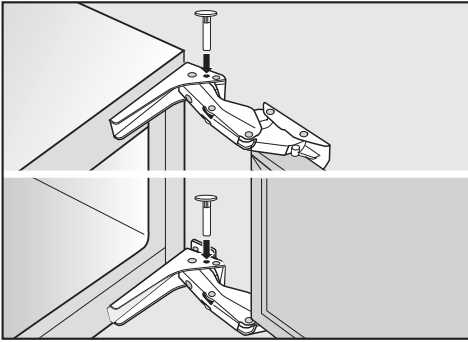

- Insert the limit pins provided into the hinges from above.

This will limit the opening angle of the appliance door to 90°.

Changing the door hinging

Always change the door hinge with the assistance of another person.

The appliance is supplied right-hand hinged. If left-hand hinging is required, the hinges must be changed:

You will need the following tools for changing the door hinging:

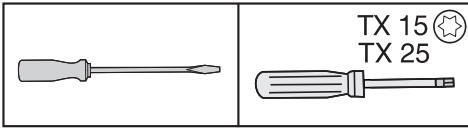

- Open the appliance door.
- Remove the shelves/bottle shelf from the appliance door (depending on model).

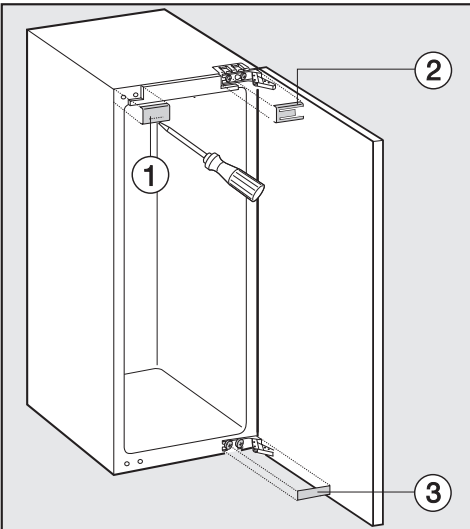

- Pull off the covers ①, ②, ③.

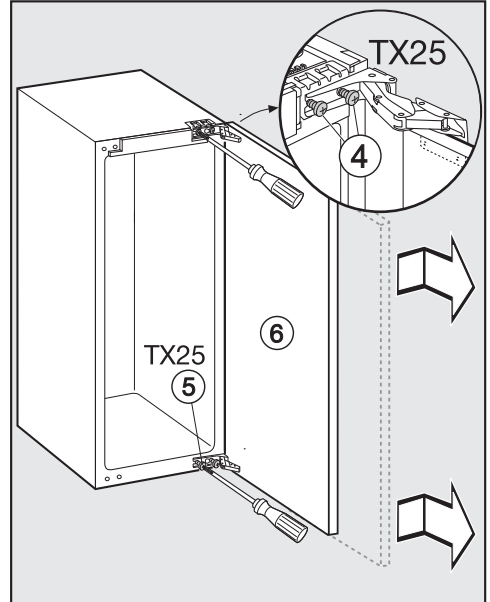

- Slightly loosen the screws ④ and ⑤ on the hinges.
- Push door ⑥ outwards and take it off its hinges.

Changing the door hinging

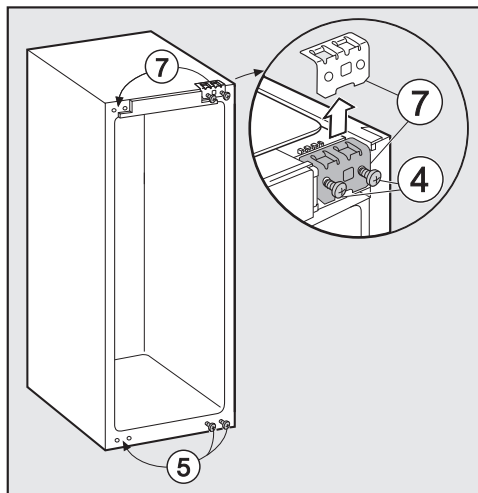

- Remove the screws (4) completely.
- Place the mounting bracket (7) on the opposite side and loosely screw in the screws (4).
- Remove screws (5) completely and loosely screw them in on the opposite side.

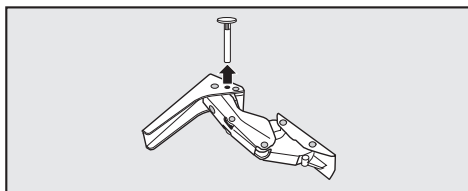

- If you had inserted pins into the hinges to limit the door's opening angle: remove the pins upwards out of the hinges.

Unscrew the door closing dampers

Attention! When removed from the unit, the soft-close mechanism snaps shut. Risk of injury!

- Place the door with the outer side downwards on a stable surface.

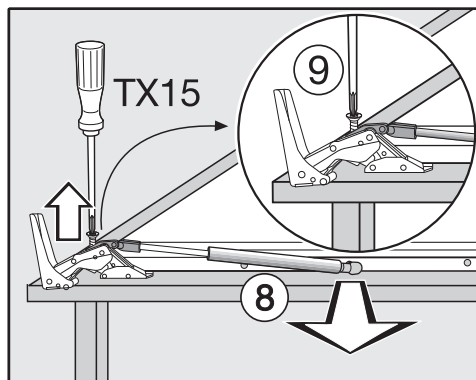

- Remove the soft-close mechanism (8) from the ball joint.
- Unscrew the mount (9) and pull the soft-close mechanism (8) towards you to remove it.

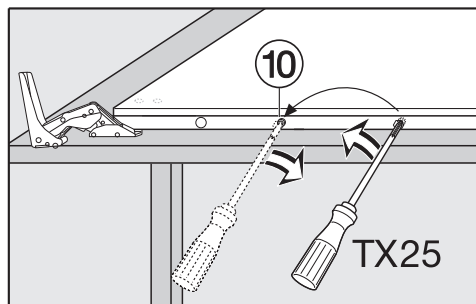

- Using a screwdriver, remove the ball joint (10) and screw it into the adjacent hole.

Changing the door hinging

- Now turn over the appliance door so that outer side faces upwards (hinges remain open).

Do not close the hinges. Danger of injury.

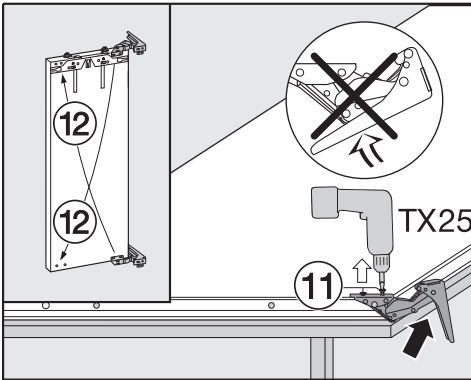

- Remove the screws ⑪.
- Place each hinge in the corner diagonally opposite from its original position ⑫.

Fastening the soft-close mechanism

- Now turn over the appliance door so that the outer side faces downwards.

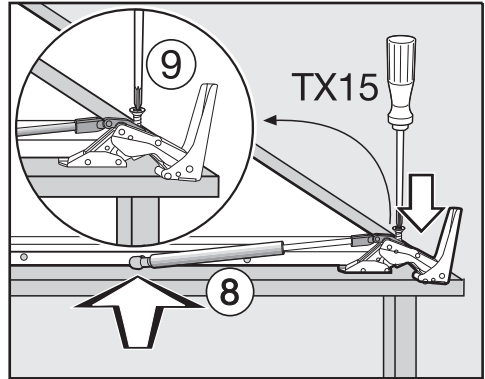

- Screw the mount ⑨ onto the hinge and firmly tighten.
- Pull the soft-close mechanism so that it extends ⑧ and hook it onto the ball joint.

Changing the door hinging

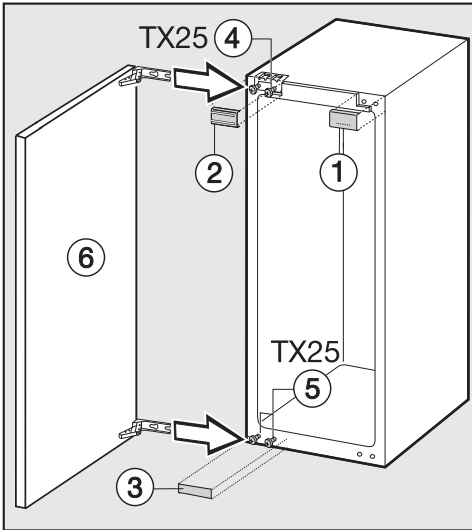

- Hang the appliance door ⑥ onto the pre-fitted screws ④ and ⑤, and then tighten the screws ④ and ⑤.
- Replace the covers ①, ②, and ③.

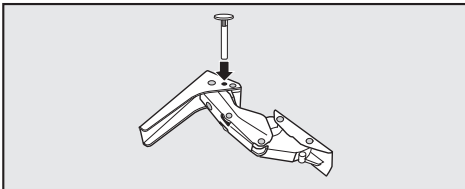

- Refit the locking pins into the top of the hinges to prevent the doors opening too far.

Installing the appliance

Two people are required to install the appliance.

- Install the appliance in a stable, solid housing unit, positioned on an even and level floor.
- Secure the housing unit against tipping.

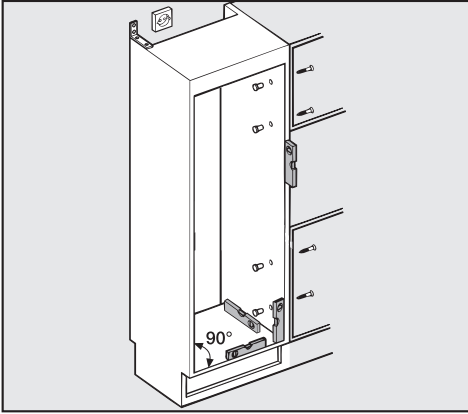

- Use a level to align the housing unit. The corners of the housing unit must be at a 90° angle to each other, otherwise the cabinet door will not align correctly with all 4 corners of the housing unit.
- The required ventilation cross-sections must be ensured (see "Installation - Ventilation" and "Installation dimensions").

To install the appliance you will need the following tools:

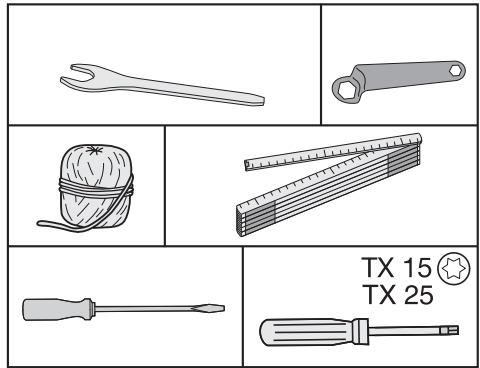

Installing the appliance

Parts required for installation

All installation parts are number coded. This coding is also used in the installation instructions.

– Required for installing the appliance in its housing unit:

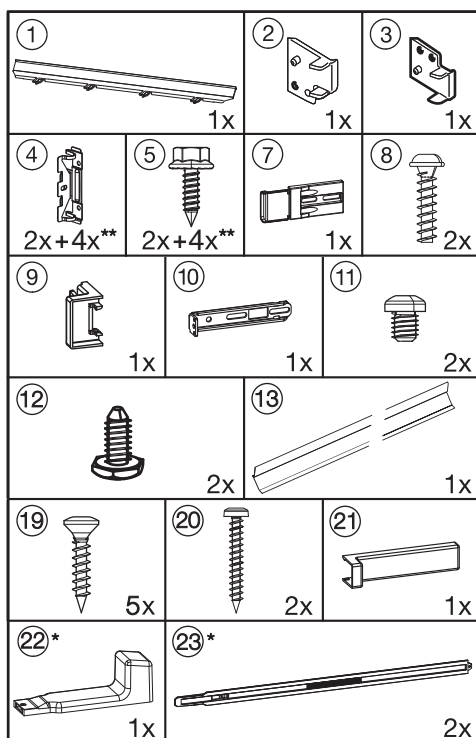

* These parts are only supplied with appliances with a niche height of 55" (140 cm) or more.

** Number depending on niche height. Also contains additional installation parts for fitting large or divided furniture doors.

– Required for fitting the cabinet door:

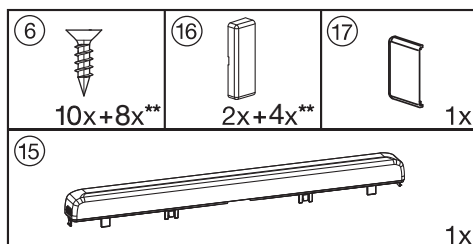

** Number depending on niche height. Also contains additional installation parts for fitting large or divided furniture doors.

All installation instructions given are for a right-hand hinged appliance. If you have converted the appliance to left-hand hinging, you will need to adapt these instructions accordingly.

Preparing the appliance

- Position the appliance in front of the housing unit.

Installing the appliance

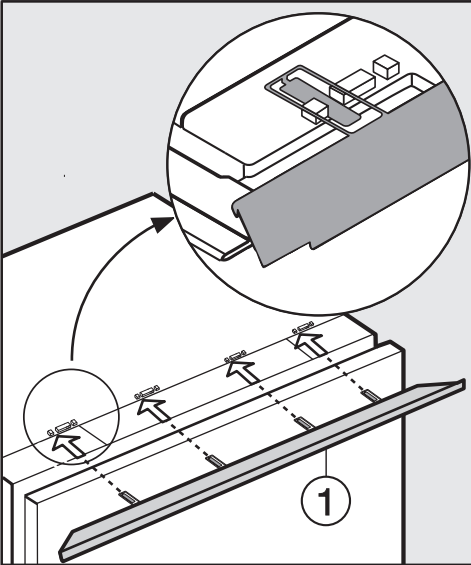

- Fit the straps of the compensation strip ① into the strut seats from the front.

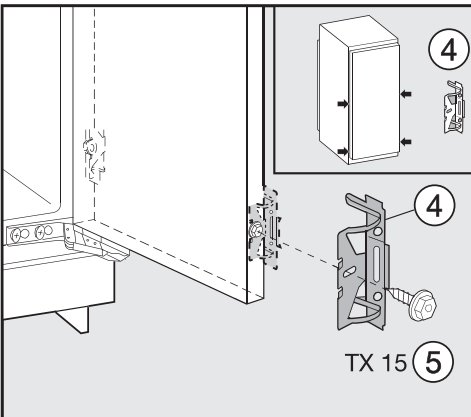

- Screw fixing bracket ④ using hex screw ⑤ to the pre-drilled holes in the appliance door. Using the pre-drilled holes in the appliance door, secure a second pair of fixing brackets ④ in the handle area of the door.

- Push the appliance two-thirds of the way into the installation space. Ensure that the power cord does not get caught.

Tip to help you push it into position:

Tie a piece of string around the plug to "increase" the length of the power cord. Then pull the cord by the end of the string through the housing unit. It will then be easier to connect once the appliance is in the unit.

Only in the case of 5/8" (16 mm) thick unit walls:

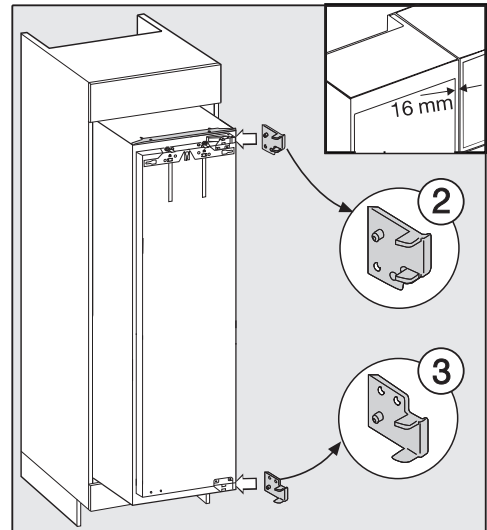

- Clip the spacers ② and ③ on the right-hand side of the hinges.
- Open the appliance door.

Installing the appliance

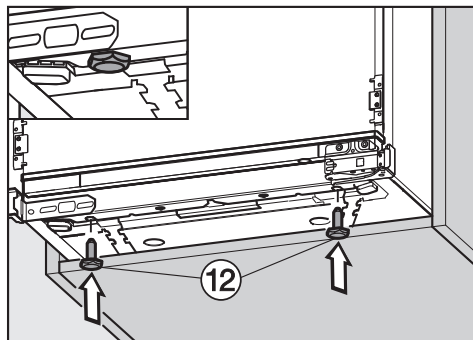
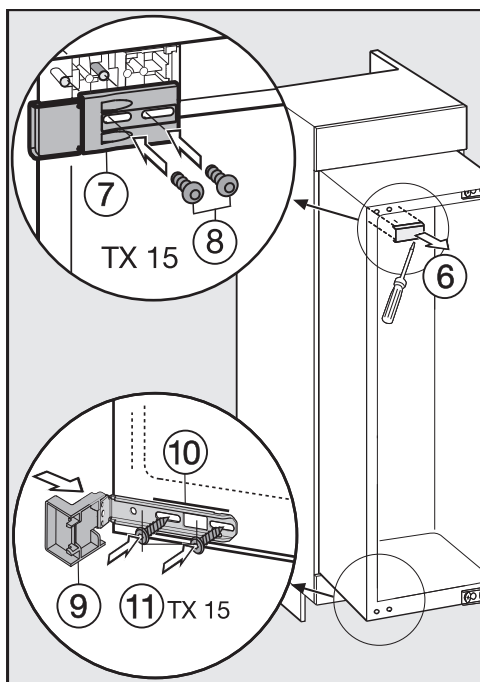

- Screw in adjustable feet 12 completely.

- Remove the cover 6.
- Secure the fastening part 7 using screws 8 loosely into the top left-hand side of the appliance. Do not tighten the screws so that you can adjust the position of this part.
- Fit the cover 9 onto the fixing bracket 10.
- Then screw fixing bracket 10 using screws 11 loosely into the bottom of the appliance. Do not tighten the screws so that you can adjust the position of this part.

Installing the appliance

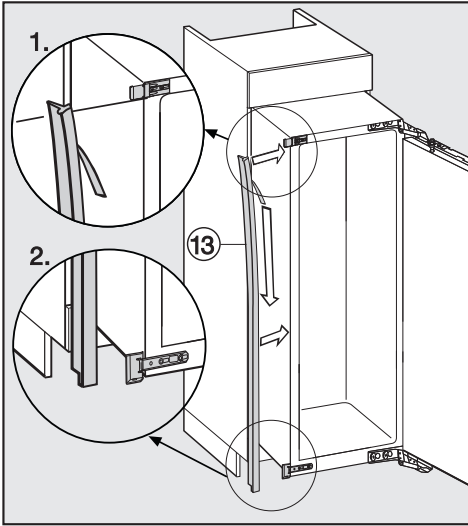

- Carefully remove the protective foil from sealing strip ⑬.
- Secure the sealing strip ⑬ flush with the front of the appliance on the door opening side.
 1. Position the sealing strip flush with the lower edge of the top fixing.
 2. Stick it down along its entire length.

Installing the appliance

- Push the appliance into the niche until all of the brackets are in line with the front edge of the furniture side wall.

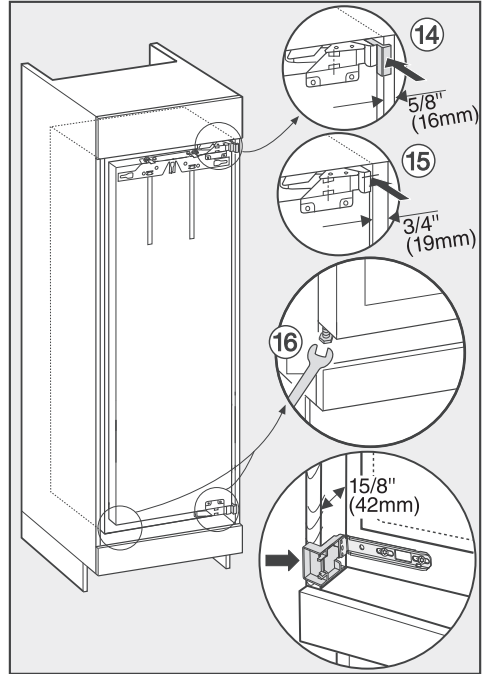

- ⑭ **With 5/8" 16 mm thick walls:**
The spacers should touch the front edge at the top and bottom of the side walls of the housing unit.
- ⑮ **With 3/4" (19 mm) thick walls:**
The front edges of the top and bottom hinges should be flush with the front edge of the housing side walls.

Installing the appliance

- Check the position of the fixing bracket at the top and bottom front edge of the cabinet side wall again.

This will help maintain a **1 5/8" (42 mm)** distance all the way around from the front edges of the cabinet side walls.

On cabinetry with door fittings (e.g. stubs, seals etc.) the dimension of these must be taken into account when making sure there is a gap all round of **1 5/8" (42 mm)**.

- Pull the appliance forward the appropriate amount to suit the installed dimensions.

The hinges and covers will now be positioned to suit the dimensions.

Tip: Remove the door fittings. This will ensure that the door is flush with the surrounding kitchen unit cabinet doors.

- ⑩ Align the appliance on both sides by altering the adjustable feet using the wrench supplied.

If the all round gap of 1 5/8" (42 mm) is not maintained between the appliance housing and the front edge of the housing unit side wall, the door may not shut properly. This can cause ice to build up, condensate to accumulate and lead to faults in the appliance. These can all lead to increased energy consumption.

Securing the appliance in the niche

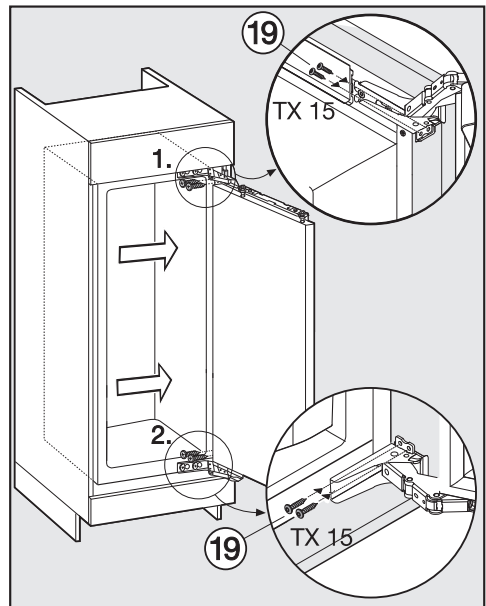

- Push the hinged side of the appliance to the cabinet wall.
- Screw the particleboard screws ⑲ through the hinge plates at the top, bottom and then in the middle to secure the appliance to the housing unit.

Installing the appliance

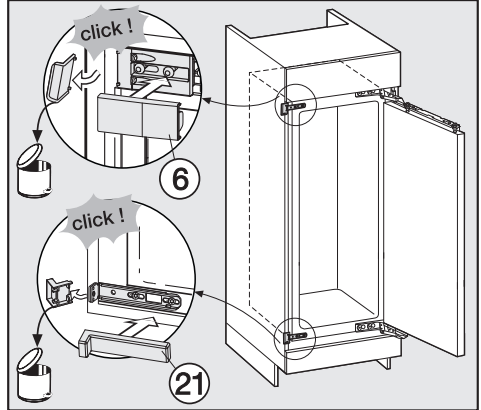
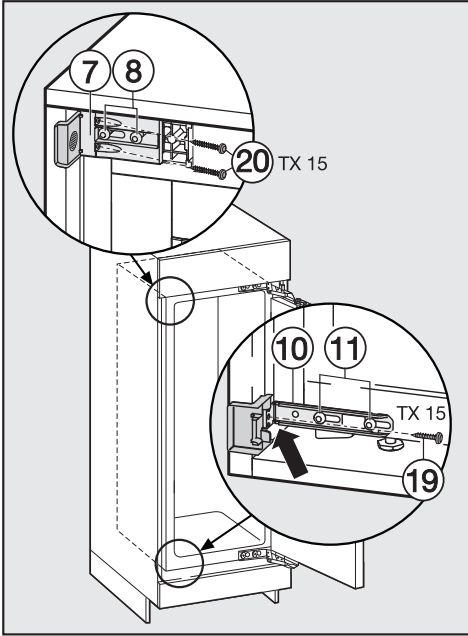

- Push the loose bracket against the cabinet wall.
- Secure mounting bracket ⑩ to the housing unit side wall with screw ⑲. Drill holes in the housing unit side walls if necessary.
- Secure bracket ⑦ to the housing unit side walls using screws ⑳. Drill holes in the housing unit side walls if necessary.
Attention! Push the protruding bracket using your thumb towards the housing unit wall while tightening the screws. The appliance must not pull back into the unit.
- Retighten screws ⑧ and ⑪.

- Snap off any protruding ends from the mounting bracket. They are no longer required.
- Replace covers ⑥ and ⑳ on the mounting brackets.

Installing the appliance

Only for an appliance with a niche height greater than 55" (140 cm)

For additional stability of the appliance in the unit, push the rods supplied in underneath the appliance between it and the floor of the housing unit:

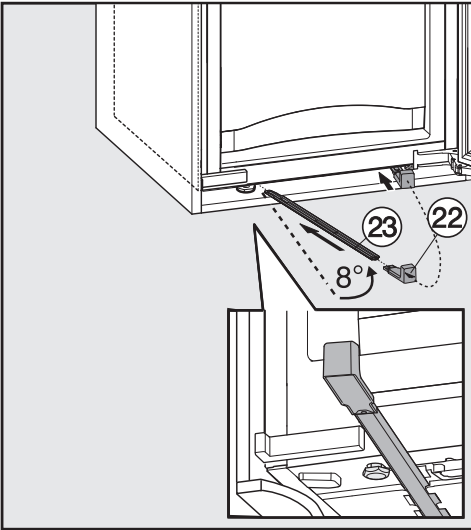

- Then secure handle ②② to one of the rods ②③.
- Use the handle to push the rod into the guide as far as it will go. Remove the handle and fit it to the other rod and push this into its guide as far as it will go.

Important! Keep the handle somewhere safe in case you ever need to fit the appliance into a new housing unit.

- Close the appliance door.

Installing the custom door front

The cabinet door must be at least of 5/8" (16 mm) thick and not exceed 3/4" (19 mm) thick.

The following gap dimensions must be maintained:

- The gap between the cabinet door and the unit door above must be at least 1/8" (3 mm).
- The vertical gap between cabinet doors should also be about 1/8" (3 mm). The exact dimension will vary depending on the radius of the cabinet door edges.

If fitted in a run of units make sure that the top edge of the cabinet door is at the same height as neighboring unit doors.

The door panel must be installed correctly and not under tension.

Installing a door front which is heavier than the maximum permitted could damage the hinges. This can cause damage.

Before installing door fronts ensure that the weight of the door does not exceed the maximum permitted:

Appliance	Maximum weight of furniture door in lb (kg)
FNS 37492 iE	50.7 (23)

When fitting large or divided cabinet doors an extra fitting kit or set of fixing brackets should be used. These are available to order from Miele.

Installing the appliance

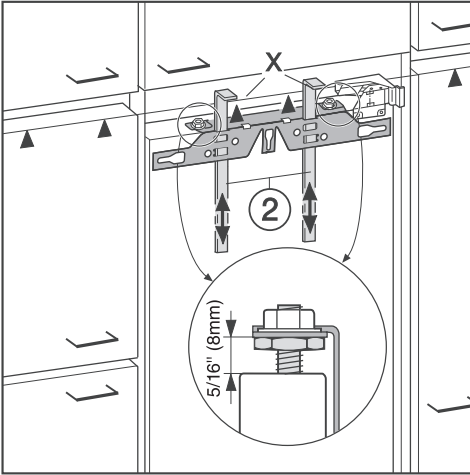

- A gap of 5/16" (8 mm) is set ex works between the appliance door and the fixing bracket. Double check this gap and reset it if necessary.
- Push the installation aids ② up to the height of the cabinet door: the lower edge X of the installation aids must be at the same height as the upper edge of the cabinet door being fitted (see ▲ on the diagram).

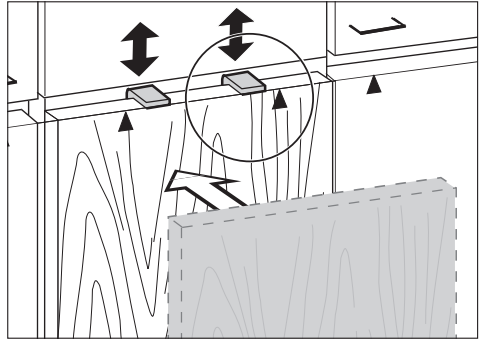

Tip: Push installation aids ② together with the cabinet front up to the height of the adjoining unit cabinet doors.

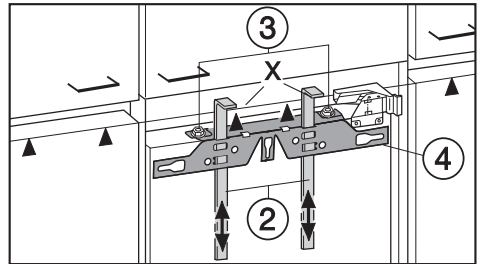

- Remove the nuts ③ and take the mounting bracket ④ off together with installation aids ②.

Installing the appliance

- Place the door panel with the outer side downwards on a stable surface.

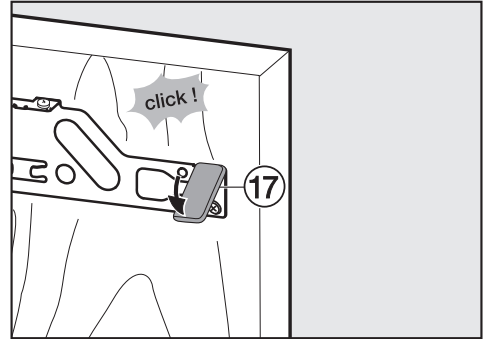
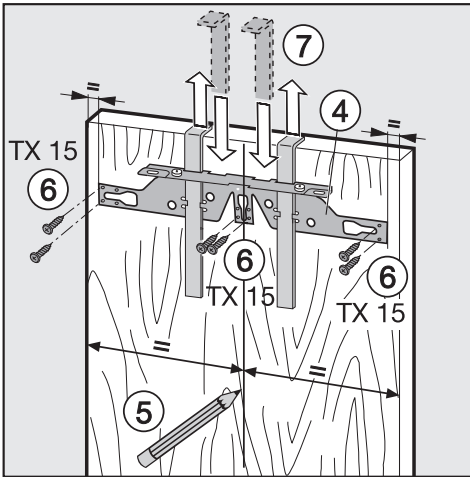

- Using a pencil, lightly mark a line down the center of the inside of the panel ⑤.
- Hang the fixing bracket ④ with the fitting aids onto the **inside** of the cabinet door. Align the bracket centrally.
- Attach the mounting bracket securely using at least 6 short particle board screws ⑥. Drill holes in the cabinet door if necessary.
- Pull the installation aids upwards to remove them ⑦. Turn them around and fit them into the middle slots on the bracket for safe keeping.

- Secure the side cover ⑰ to the bracket on the opposite side of the hinge.
- Turn the door over and attach the handle (if required).

Installing the appliance

- Open the appliance door.

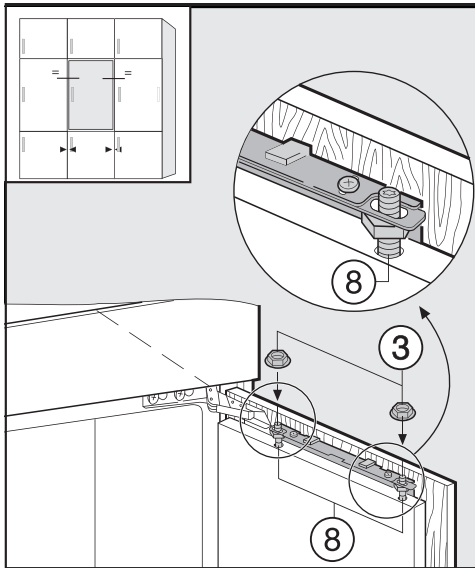

- Hang the door panel on the threaded bolts (8).
- Screw the nuts (3) loosely onto bolts.
- Close the door and check the distance between the door and neighboring cabinet doors. The gaps should be even.

Adjusting the position of the door

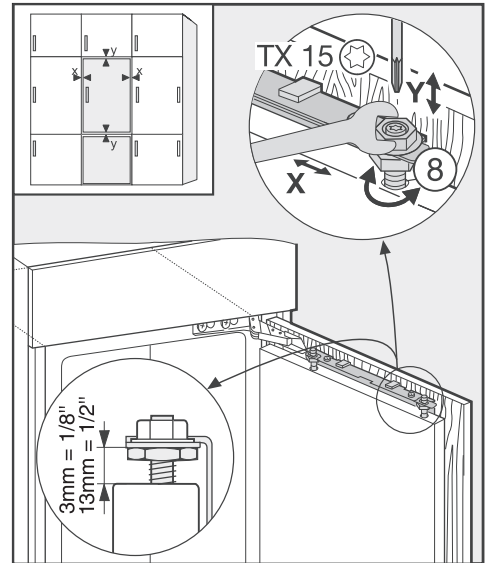

- **Side adjustments (X)**
- Adjust the door panel.
- **Height adjustment (Y)**
- Tighten the nuts with a wrench (8).

A gap of 3/8" (8 mm) is factory set between the appliance door and the bracket. This must only be adjusted within its permitted range.

Installing the appliance

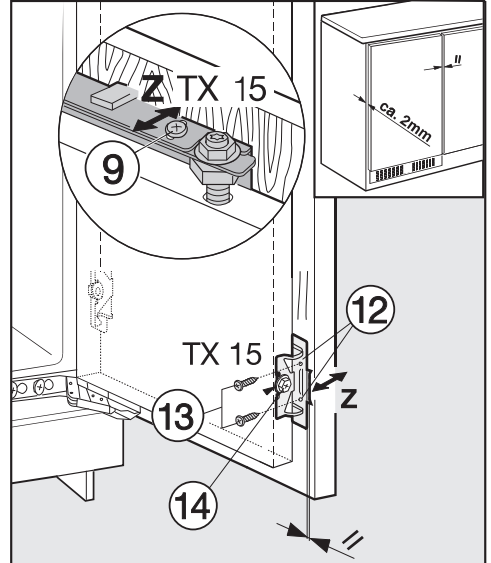
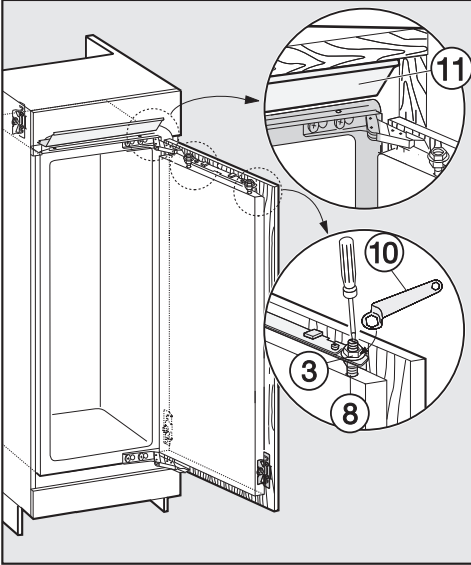

- While counterholding adjusting bolts ⑧ with a screwdriver, tighten nuts ③ on the appliance door with ring spanner ⑩.
- Cover strip ⑪ must be completely hidden in the niche, and must not protrude.

- Drill holes ⑫ in the door panel and fit screws ⑬. Make sure the two metal edges are aligned (Symbol //).
- Close the appliance door and the cabinet door.

Adjusting the position of the door

– Depth adjustment (Z)

- Loosen screws ⑨ at the top of the appliance door, and screw ⑭ on the mounting bracket at the bottom. By moving the cabinet door, create a gap of 1/16" (2 mm) between the cabinet door and the housing unit.

Installing the appliance

- Tighten all the screws again.

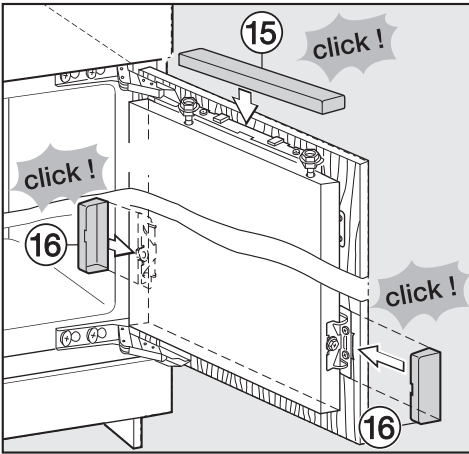

The following confirms that the appliance is correctly installed:

- The door must close properly.
- The door must not touch the furniture body.
- The seal at the upper corner of the side with the handle contacts tightly.

- Replace top cover ⑮, and click it into place.

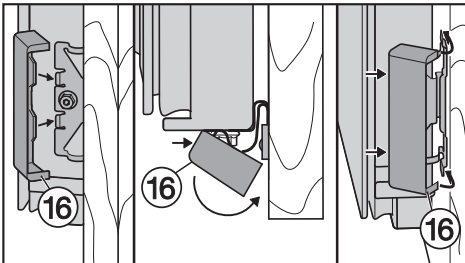

- Replace side covers ⑯, making sure you hear them click into place.

Please have the model and serial number of your appliance available before contacting Technical Service.



U.S.A.
Miele, Inc.

National Headquarters

9 Independence Way
Princeton, NJ 08540
Phone: 800-843-7231
609-419-9898
Fax: 609-419-4298
www.mieleusa.com

Technical Service & Support
Nationwide

Phone: 800-999-1360
Fax: 888-586-8056

TechnicalService@mieleusa.com

Canada
Miele Limited

Headquarters and Showroom

161 Four Valley Drive
Vaughan, ON L4K 4V8
Phone: 800-643-5381
Fax: 905-532-2290
www.miele.ca
professional@miele.ca
(commercial enquiries)

MieleCare National Service

Phone: 800-565-6435
905-532-2272
Fax: 905-532-2292
customercare@miele.ca
(general and technical enquiries)



www.miele-shop.com

FNS 37492 iE



en - US

M.-Nr. 10 117 220 / 01