

**Upright Freezer**  
**SINGLE DOOR SERIES**

# **USER MANUAL**

**MRU07M4BSL**  
**MRU07M4BWW**

Warning notices: Before using this product, please read this manual carefully and keep it for future reference. The design and specifications are subject to change without prior notice for product improvement. Consult with your dealer or manufacturer for details. The diagram above is just for reference. Please take the appearance of the actual product as the standard.



## THANK YOU LETTER

Thank you for choosing Midea! Before using your new Midea product, please read this manual thoroughly to ensure that you know how to operate the features and functions that your new appliance offers in a safe way.

# CONTENTS

THANK YOU LETTER .....	01
SPECIFICATIONS .....	02
PRODUCT OVERVIEW .....	03
PRODUCT INSTALLATION .....	04
OPERATION INSTRUCTIONS .....	10
CLEANING AND MAINTENANCE .....	11
TROUBLESHOOTING .....	12

# SPECIFICATIONS

<b>Product model</b>	<b>MRU07M4BSL/MRU07M4BWW</b>
Volume	7.1cu.ft.(200L)
Rated Voltage	AC115V
Rated Frequency	60Hz
Rated Current	1.5A
Refrigerant	R600a
Amount	2.47oz(70g)
Overall Dimension (W x D x H)	21.7 x 22.4 x 50 in(55.0 x 57.0 x 127.0 cm)

# PRODUCT OVERVIEW

## Names of components

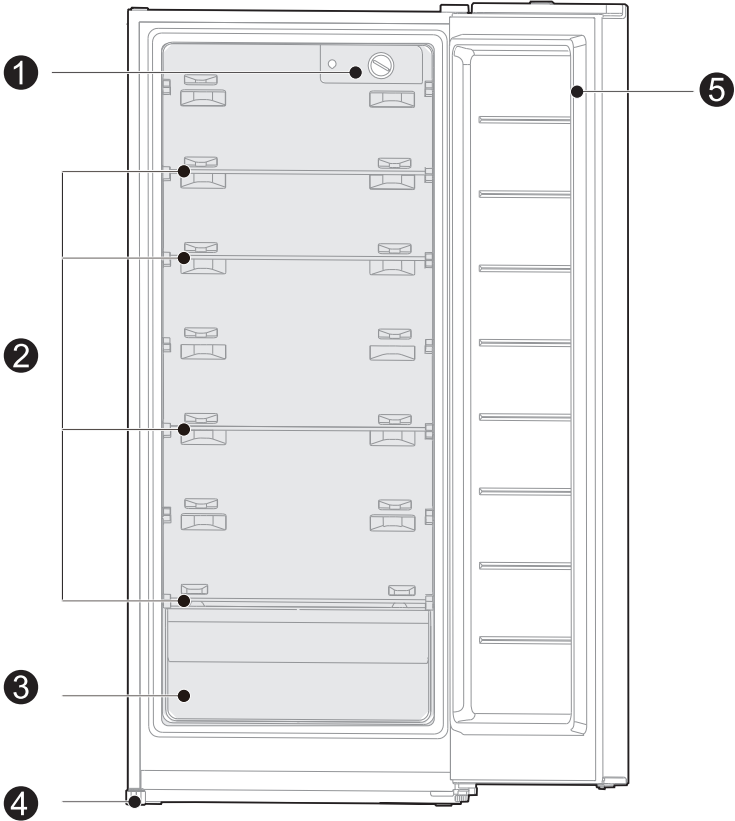

1 Thermostat knob

2 Glass shelf

3 Drawer (optional)

4 Leveling foot

5 Door

### ● ATTENTION

The picture above is only for reference. The actual configuration will depend on the physical product or statement by the distributor

# PRODUCT INSTALLATION

## Install Instruction

### Finding a suitable location

- This freezer is designed to be free standing only, and should not be recessed or built-in.
- The freezer should be placed in a well-ventilated indoor place; the ground shall be flat and sturdy .
- Keep away from heat and avoid direct sunlight. Do not place the freezer in moist or watery places to prevent rust or reduction of insulating effect.

### Dimensions and Clearances

- Too small of a distance from adjacent items may result in the degradation of freezing capability and increased electricity costs. Allow over 100 mm of clearance from each adjacent wall when installing the appliance.

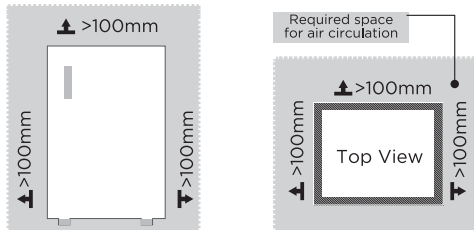

### Providing a proper power supply

- Check your local power source. This freezer requires a AC115 V, 60 Hz power supply.
- Use a receptacle that accepts the grounding prong. The power cord is equipped with a 3-prong (grounding) plug which mates with a standard 3-prong (grounding) wall outlet to minimize the possibility of electric shock hazard from this freezer.



## CAUTION

The freezer should always be plugged into its own individual electrical outlet which has a voltage rating that matches the rating plate.

Never unplug your freezer by pulling on the power cord. Always grip the plug firmly and pull straight out from the outlet.

## Start to use

- The freezer shall stay in an upright position for half an hour before connecting power when it is firstly started.
- The freezer shall run 2 to 3 hours before loading fresh or frozen foods; the freezer shall run for more than 4 hours in summer in advance considering that the ambient temperature is high.

Space requirement diagram (when the door is open and when the door is closed)

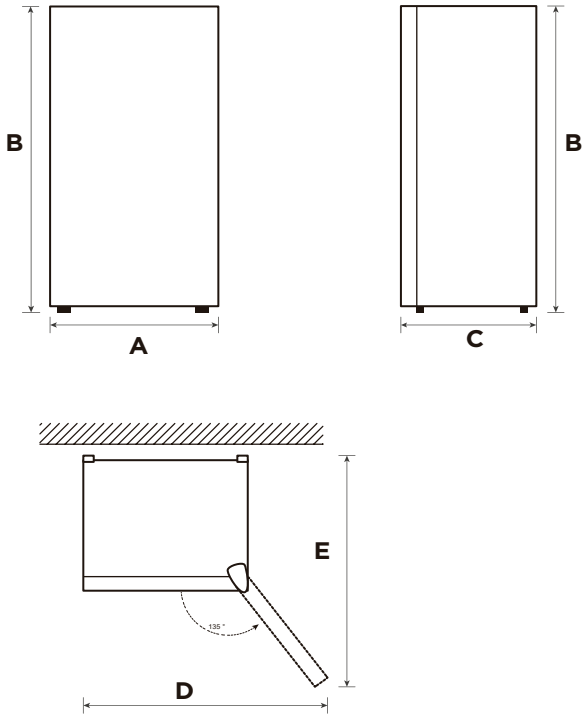

Width	Overall Height	Depth	Depth doors open $135^\circ$	Width doors open $135^\circ$
A	B	C	D	E
550	1270	570	990	860

Notice: All dimensions in mm

## Door right-left change (optional)



Based on the location where you plan to use your refrigerator, you may find it more convenient to reverse the position of the door.



### CAUTION

CAUTION: To avoid injury to yourself or your property, we recommend that someone assist you during the door reversal process.

#### List of tools to be provided by the user

	Cross screwdriver
	Thin-blade screwdriver
	Masking tape

#### Parts to be used for door reverse

SN	PART	amount	note
1	Right upper hinge	1	Pre-installed on the refrigerator, removed when the door is reversed, and kept for future use
2	Upper right hinge cover	1	
3	Hole cover	1	
4	Stopper	1	Pre-installed on the refrigerator, still used when door is reversed
5	Stopper Lower hinge	1	
6	Leveling foot	1	
7	Left upper hinge	1	In the attached plastic bag, take them out for use when door is reversed
8	Upper left hinge cover	1	

### STEP

1. Remove all food from door shelves. Fix the door by tapes.
2. Dismantle hinge hole cap, the upper right hinge cover, fitting screws of upper right hinge, and remove the upper right hinge, please keep the door vertical in whole process for avoiding falling down;

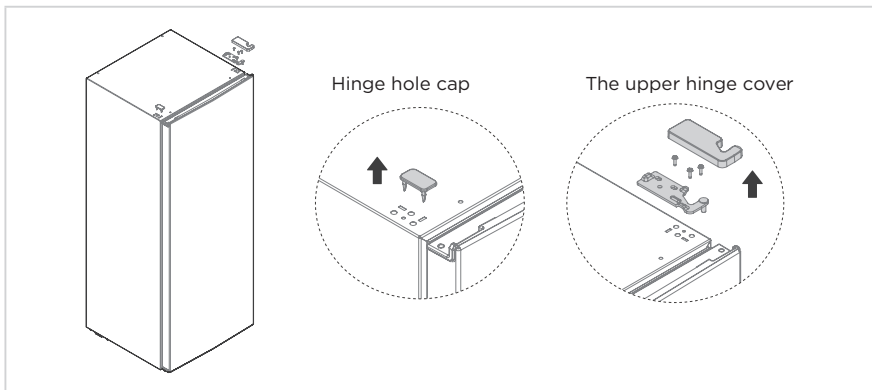

3. Remove the door;
4. Dismantle the door stopper, and install it on other side;

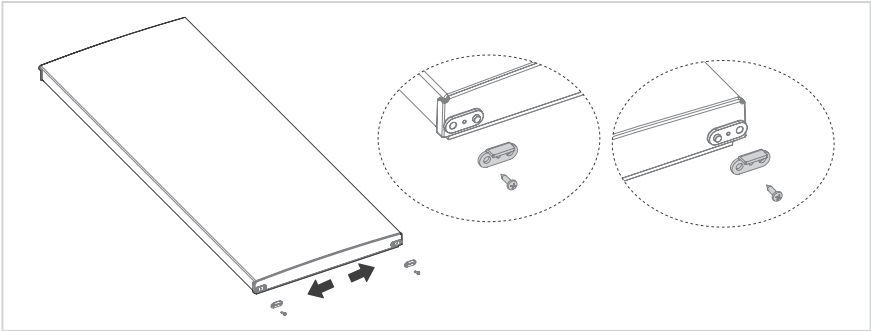

5. Dismantle the lower hinge and leveling foot;
6. Install the lower hinge and leveling foot on lower left side of cabinet;

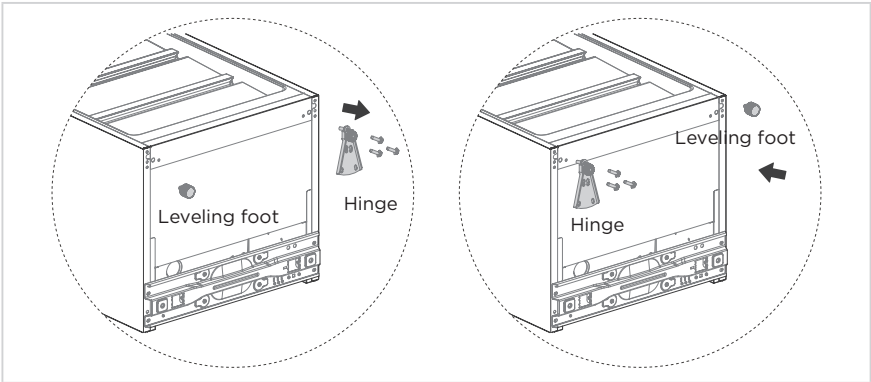

7. Put the door on lower hinge vertically, and validate the gas tightness of door gasket, take out the spare upper left hinge and hinge cover from accessory bag, then install the upper left hinge by fitting screws. finally to install the hinge cover , and cover the hinge hole cap on upper right side.

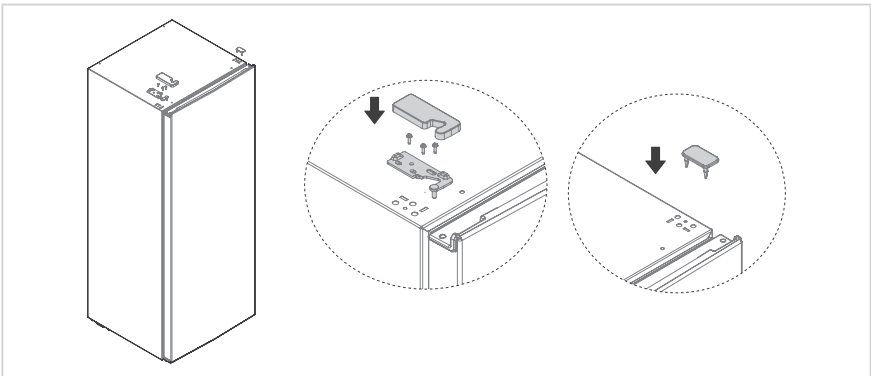



## Leveling feet

To avoid vibration, the unit must be leveled.

If required, adjust the leveling screws to compensate for the uneven floor.

The front should be slightly higher than the rear to aid in door closing.

Leveling screws can be turned easily by tipping the cabinet slightly.

Turn the leveling screws counterclockwise  to raise the unit, clockwise  to lower it.

## Moving the appliance

1. Remove all food from inside the appliance.
2. Pull the power plug out, insert and fix it into the power plug hook at the rear or on top of the appliance.
3. Tape parts such as shelves and the door handle to prevent from falling off while moving the appliance.
4. Move the appliance with more than two people carefully. When transporting the appliance over a long distance, keep the appliance upright.
5. After installing the appliance, connect the power plug into a socket out to switch on the appliance.

### ATTENTION

Precautions before operation:

Before making changes the refrigerator must be disconnected from power. precautions should be taken to prevent any personal injury.

## Tips for energy saving

- Do not place the appliance near cookers, radiators or other heat sources. If the ambient temperature is high, the compressor will run more frequently and for longer, resulting in increased energy consumption.
- Ensure that there is sufficient ventilation at the base of the appliance, on the sides of the appliance and at the back of the appliance. Never cover ventilation openings.
- Please also observe the spacing dimensions in the chapter „Installation“.
- The arrangement of drawers, shelves and racks as shown in the illustration offers the most efficient use of energy and should therefore be retained as far as possible. All drawers and shelves should remain in the appliance to keep the temperature stable and save energy.
- To obtain a larger storage space (e.g. for large refrigerated/frozen goods), the middle drawers can be removed. The top and bottom drawers and shelves should be removed last if necessary.
- An evenly filled refrigerator/freezer compartment contributes to optimal energy use. Therefore, avoid empty or half-empty compartments.
- Allow warm food to cool before placing it in the refrigerator/freezer. Food that has already cooled down increases energy efficiency.
- Allow frozen food to defrost in the refrigerator. The coldness of the frozen food reduces the energy consumption in the refrigerator compartment and thus increases the energy efficiency.
- Open the door only as briefly as necessary to minimise cold loss. Opening the door briefly and closing it properly reduces energy consumption.
- The door seals of your appliance must be perfectly intact so that the doors close properly and energy consumption is not increased unnecessarily.

# OPERATION INSTRUCTIONS

## Control Panel

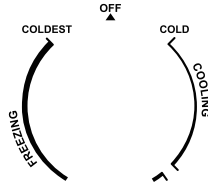

- After the upright freezer is powered on, when the temperature control knob rotates clockwise, the temperature in the freezer will gradually decrease, and when it rotates counterclockwise, the temperature will gradually increase; when knob is adjusted within the scope of “COOLING”, the box is refrigerator, when knob is adjusted within the scope of “FREEZING”, the box is frozen.
- “OFF” file indicates stop.
- When selecting the refrigeration function, it is recommended that the temperature control knob be set in the middle of the refrigeration icon area. During refrigeration, there may be water drops on the inner wall of the liner, which is normal and the refrigerator can be used normally.

### ATTENTION

The actual control panel may differ from model to model.

## Tips on storing food

- The low temperature of upright freezer may keep food fresh for a long time and it is mainly used to store frozen foods and making ice.
- The upright freezer is suitable for storage of meat, fish, shrimp, dumplings, rice balls and other foods not to be consumed in short term.
- Chunks of meat are preferably to be divided into small pieces for easy access. Please be noted food shall be consumed within the shelf time.

When the machine is in freezing mode, please cut off the power in time and defrost it manually under the following two conditions. Defrosting water shall be treated outside the cabinet, and the space inside shall be cleaned.

1. When the machine is in freezing mode for a long time, the inner wall of the cabinet will frost, and the frost will thicken with time, which will affect its cooling effect. In this case, please cut off the power in time for manual defrosting, clean the inner wall and then power on to continue using the machine.
2. When the freezing mode is switched to the refrigeration mode, the temperature inside the cabinet will rise. In order to avoid a large amount of defrosting water flowing out of the box and damaging the floor and other items, please cut off the power for manual defrosting before putting food in.

# CLEANING AND MAINTENANCE

## Defrosting

### Upright freezer shall be manually defrosted.

Disconnect the plug from the wall socket, open the door and remove all the food to a cool place.

It is recommended to remove the frost by a plastic scraper, or let the temperature rise naturally until the frost melts. Then wipe away the remaining ice and water, and plug in socket for switching on the freezer.

### ATTENTION

Soft towels or sponge dipped in water and non-corrosive neutral detergents are suggested for cleaning. The freezer shall be finally cleaned with clean water and dry cloth. Open the door for natural drying before the power is turned on. Do not use hard brushes, clean steel balls, wire brushes, abrasives, such as toothpastes, organic solvents (such as alcohol, acetone, banana oil, etc.), boiling water, acid or alkaline items clean refrigerator considering that this may damage the fridge surface and interior.

### CAUTION

Other mechanical devices or other means shall not be used to accelerate except those recommended by the manufacturer. Do not damage the refrigerant circuit.

## Stop using

### Power failure:

In case of power failure, even if it is in summer, foods inside the appliance can be kept for several hours; during the power failure, the times of door opening shall be reduced, and no more fresh food shall be put into the appliance.

### Long-time nonuse:

The appliance shall be unplugged and then cleaned; then the doors are left open to prevent odor.

### Moving:

Before the refrigerator is moved, take all objects inside out, fix the glass partitions, vegetable holder, freezing chamber drawers and etc. with tape, and tighten the leveling feet; close the doors and seal them with tape. During moving, the appliance shall not be laid upside down or horizontally, or be vibrated; the inclination during movement shall be no more than 45°.

### ATTENTION

The appliance shall run continuously once it is started. Generally, the operation of the appliance shall not be interrupted; otherwise the service life may be impaired.

Foods can be preserved for a couple of hours even in summer in case of power failure; it is recommended to reduce the frequency of opening door.

# TROUBLESHOOTING

The following simple issues can be handled by the user. Please call the after-sale service department if the issues are not solved.

Problem	Possible reason
Failed operation	<ul style="list-style-type: none"> <li>• Check whether the appliance is connected to power or whether the plug is in well contact</li> </ul>
	<ul style="list-style-type: none"> <li>• Check whether the voltage is too low</li> </ul>
	<ul style="list-style-type: none"> <li>• Check whether there is a power failure or partial circuits have tripped</li> </ul>
Odor	<ul style="list-style-type: none"> <li>• Odorous foods shall be tightly wrapped</li> </ul>
	<ul style="list-style-type: none"> <li>• Check whether there is any rotten food</li> </ul>
	<ul style="list-style-type: none"> <li>• Clean the inside of the refrigerator</li> </ul>
Long-time operation of the compressor	<ul style="list-style-type: none"> <li>• Long operation of the refrigerator is normal in summer</li> </ul>
	<ul style="list-style-type: none"> <li>• when the ambient temperature is high It is not suggestible having too much food in the appliance at the same time</li> </ul>
	<ul style="list-style-type: none"> <li>• Food shall get cool before being put into the appliance</li> </ul>
	<ul style="list-style-type: none"> <li>• The doors are opened too frequently</li> </ul>
Light fails to get lit	<ul style="list-style-type: none"> <li>• Check whether the refrigerator is connected to power supply and whether the illuminating light is damaged</li> </ul>
	<ul style="list-style-type: none"> <li>• Have the light replaced by a specialist</li> </ul>
Door can not be properly closed	<ul style="list-style-type: none"> <li>• The door is stuck by food packages Too much food is placed</li> </ul>
	<ul style="list-style-type: none"> <li>• The upright freezer is not placed properly.</li> </ul>
Loud noises	<ul style="list-style-type: none"> <li>• Check whether the floor is level and whether the refrigerator is placed stably</li> </ul>
	<ul style="list-style-type: none"> <li>• Check whether accessories are placed at proper locations</li> </ul>

Problem	Possible reason
Door seal fails to be tight	<ul style="list-style-type: none"> <li>• Remove foreign matters on the door seal</li> </ul>
	<ul style="list-style-type: none"> <li>• Heat the door seal and then cool it for restoration (or blow it with an electrical drier or use a hot towel for heating)</li> </ul>
Water pan overflows	<ul style="list-style-type: none"> <li>• There is too much food in the chamber or food stored contains too much water,resulting in heavy defrosting</li> </ul>
	<ul style="list-style-type: none"> <li>• The doors are not closed properly, resulting in frosting due to entry of air and increased water due to defrosting</li> </ul>
Hot housing	<ul style="list-style-type: none"> <li>• Heat dissipation of the built-in condenser via the housing, which is normal When housing becomes hot due to high ambient temperature, storage of too much food or shutdown of the compressor is shut down, provide sound ventilation to facilitate heat dissipation</li> </ul>
Surface condensation	<ul style="list-style-type: none"> <li>• Condensation on the exterior surface and door seals of the refrigerator is normal when the ambient humidity is too high. Just wipe the condensate with a clean towel.</li> </ul>
Abnormal noise	<ul style="list-style-type: none"> <li>• Buzz: The compressor may produce buzzes during operation, and the buzzes are loud particularly upon start or stop. This is normal.</li> </ul>
	<ul style="list-style-type: none"> <li>• Creak: Refrigerant flowing inside of the appliance may produce creak, which is normal.</li> </ul>



*make yourself at home*



[www.midea.com](http://www.midea.com)

© Midea 2022 all rights reserved