

# MRBD224 - 24" DUAL-ZONE BEVERAGE CENTER

## THE ESSENTIAL COLLECTION



### DESIGN

**Cylindrical door pull** on stainless steel model.

**Panel-ready model** accepts custom door panel.

**Matte black interiors** with **stainless steel accents** on wine racks and shelves.

**Zero-clearance, low-profile pin hinges** on stainless steel models, panel-ready models require additional clearance.

### FEATURES

Built for both **indoor & outdoor use**.

**Carbon filter** for enhanced air quality and odor reduction.

**Center Cabinet Vertical Lighting:** Complete illumination for full visibility throughout the entire interior.

**Door alarm** activates when the door is left open.

**Door lock** provides added security.

**Effortless Entry Door:** Minimizes the physical effort needed, enhancing ease of use for all family members.

**Electronic touch control** enables precise temperature selection from **37°F to 50°F in the upper zone** and **50°F to 61°F in the lower zone**.

**Evenly distributed forced-air refrigeration system** delivers rapid cool down and temperature stability.

**Field reversible door** is shipped right-hand hinged.

**Four leveling legs** adjustable up to 1 inch.

**Low-E coated, argon gas filled, double thermopane glass door** provides protection from harmful UV light.

**Sabbath Mode** disables interior lights, alarms, and digital displays while maintaining consistent cooling performance.

**Six-color multi-point LED lighting in adjustable white:** bright white, warm white, cool white, and light blue, deep blue, and teal.

### STORAGE

**4.8 cu. ft. capacity** stores up to **18 wine bottles** and **112 12-oz cans**.

Additional **lower storage area**.

**Two adjustable glass shelves**.

**Two full-extension, durable wire wine racks** on ball-bearings.

### CAPACITY

Volume	4.8 cu. ft.
Cans (12 oz)	112
Wine Bottles (750 mL)	18

### DIMENSIONS

Product Depth	22 9/16" (57.3 cm)
Product Height (Min.)	33 5/8" (85.4 cm)
Product Width	23 1/2" (60 cm)
Product Weight	125 lbs
Shipping Depth	31" (78.7 cm)
Shipping Height	37" (94 cm)
Shipping Width	28" (71.1 cm)
Shipping Weight	145 lbs

### CUSTOM PANEL DIMENSIONS

Panel Height	29" (73.7 cm)
Panel Thickness	5/8" (1.6 cm) or 3/4" (1.9 cm)
Panel Width	23 1/8" (58.7 cm)
Panel Weight (Max.)	40 lbs
Panel Type	2" (5.1 cm) frame panel

### SUSTAINABILITY

Refrigerant Type	R600a
GWP (Global Warming Potential)	3 (very low)

### TECHNICAL DETAILS

Cord Length	6 ft.
Electrical Requirements	115V / 60 Hz / 15A

### WARRANTY

2 year parts & labor warranty / 6 year sealed system parts warranty (see complete warranty for details).



# MRBD224 - 24" DUAL-ZONE BEVERAGE CENTER

## THE ESSENTIAL COLLECTION



### INSTALLATION

No additional clearance is needed for ventilation.

Do not obstruct front grille air flow.

Panel ready model requires 3/4" or 5/8" custom panel and handle (not supplied by Marvel).

Add 5/8" to the width for panel ready models with 3/4" integrated panel.

### PRODUCT DIMENSIONS

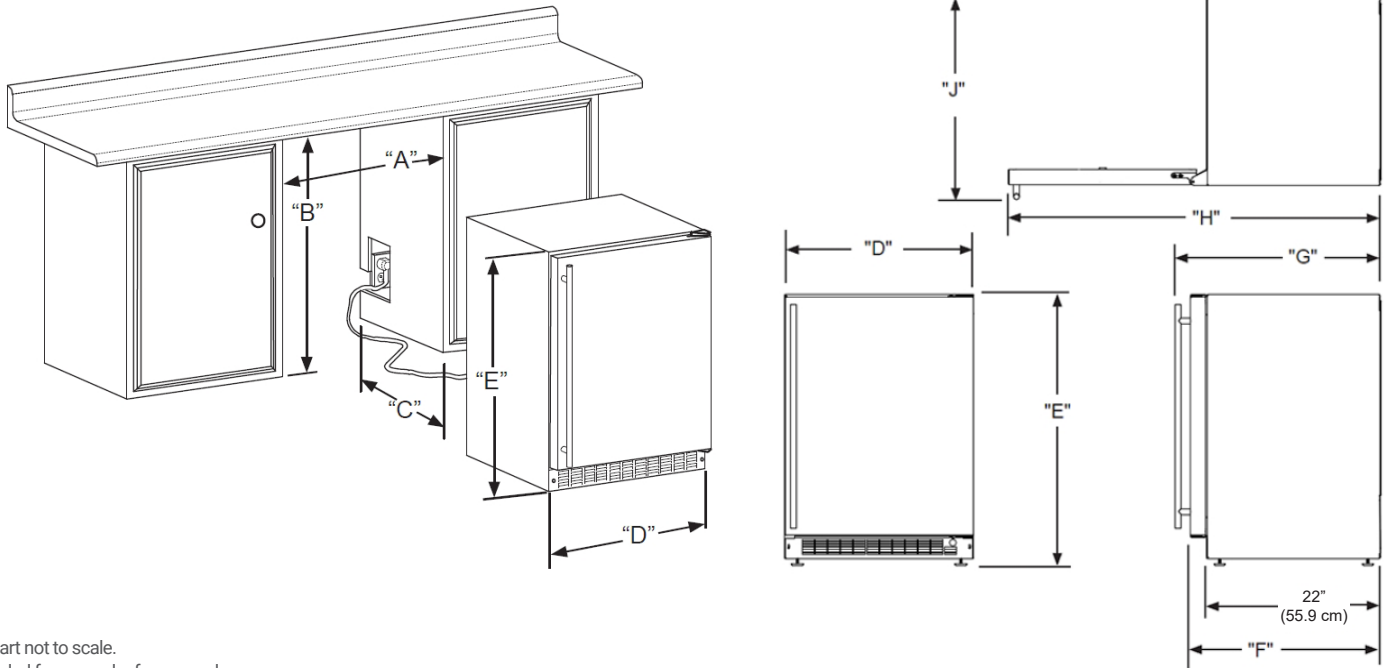

Line art not to scale.  
Intended for general reference only.

#### ROUGH IN DIMENSIONS

"A"	"B"	"C"
24"	34 1/8" to 35 1/8"	24"
(61 cm)	(86.7 cm to 89.2 cm)	(61 cm)

#### CABINET DIMENSIONS

"D"	"E"	"F"	"G"	"H"	"J"
23 1/2"	33 5/8" to 34 5/8"	22 9/16"	24 1/4"	45"	25 1/4"
(60 cm)	(85.4 cm to 88 cm)	(57.3 cm)	(61.6 cm)	(114.3 cm)	(64.2 cm)

### MODELS



**MRBD224-SG31A**

*Stainless Steel Frame Glass*



**MRBD224-IG31A**

*Panel Ready Frame Glass*